

THE UMT COMPANY

UMT is a modern cutting tool-making company situated in Bulgaria. The design of its processes incorporates the newest cutting tool machinery and manufacturing concepts, enabling

UMT to satisfy vast range of industrial needs. The company follows quality standards according to ISO 9001:2015 and prides itself with the quality, efficiency and responsibility of its work. UMT has built expertise on variety of international and local markets, fulfilling large range of requirements for standard and special carbide tools.

THE CAPABILITIES

UMT possess cutting-edge machine tool park, enabling it to produce exceptionally high quality cutting tools. For precision face and flute grinding, the company uses range of the latest WALTER and ANCA CNC grinding machines, while for cylinder grinding, ROLLOMATIC and REINECKER CNC grinding machines are being used.

UMT also performs variety of latest generation PVD coatings, making an excellent use

of its vacuum coating system PLATIT. Its own multilayer nanocomposite coatings named nanoTEC1, nanoTEC2 and nanoTEC3, deliver excellent qualities in terms of hardness, wear and heat resistance, as well as friction and chipping resistance.

For measuring, control and inspection, WALTER HELICHECK PRO and ALICONA, as well as various microscopes and measuring equipment are being used, enabling three-dimensional optical and micro scanning to be applied at any moment on any cutting tool.

HELITRONIC TOOL STUDIO (provided by WALTER Maschinenbau) as well as ToolRoom (provided by ANCA) are the superior quality 3D software products used throughout the design to production process. The software allows for almost unlimited testing, adjustments and virtual representation of the entire grinding process, before the process really begin, including immediate start of the production cycle.



О КОМПАНИИ UMT

UMT – это современная компания по производству режущего инструмента, расположенная на территории Болгарии. Проектирование процессов включает

в себя новейшее оборудование и производственные концепции, позволяющие компании UMT удовлетворить широкий спектр промышленных нужд. Компания UMT придерживается стандартов качества согласно ISO 9001:2015 и гордится надежностью, оперативностью и ответственностью выполнения работ. Компания UMT приобрела свой опыт на различных международных и локальных рынках, обеспечивая большой спрос потребностей в твердосплавном инструменте стандартных и специальных позиций.

ПРОИЗВОДСТВЕННЫЙ ПОТЕНЦИАЛ КОМПАНИИ UMT

Компания UMT располагает передовым парком станков, что позволяет производить исключительно качественный режущий инструмент. Для прецизионного торцевого шлифования и обработки канавок, компания использует ряд новейших шлифовальных станков ЧПУ WALTER и ANCA, а для шлифовки цилиндров – цилиндрические станки ЧПУ ROLLOMATIC и REINECKER.

Компания UMT применяет различные PVD покрытия последнего поколения, что достигается благодаря использованию высококачественной системы покрытий PLATIT. Есть собственный бренд многослойных нанокompозитных покрытий именуемых nanoTEC1, nanoTEC2 и nanoTEC3, обеспечивающих отличные качества в плане твердости, износостойкости и теплостойкости, а также сопротивления трению и сколов.

Для проведения замеров, технического контроля и осмотра продукции используется оборудование WALTER HELICHECK PRO и ALICONA, а также различные микроскопы и оборудование для измерений, включая трехмерное оптическое и микро-сканирование, что дает возможность произвести замеры на любом режущем инструменте в любое время работы.

Непревзойденные 3D-програмные продукты HELITRONIC TOOL STUDIO (предоставлен WALTER Maschinenbau) и ToolRoom (предоставлен ANCA) используются в процессе дизайна и производства. Программное обеспечение позволяет проводить практически неограниченные тестирования, корректировки и виртуальное представление всего процесса заточки, до момента начала производства, включая незамедлительный старт производственного цикла.

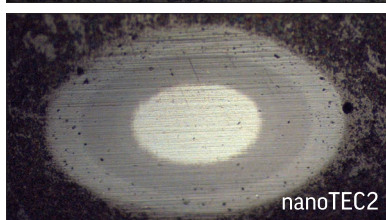
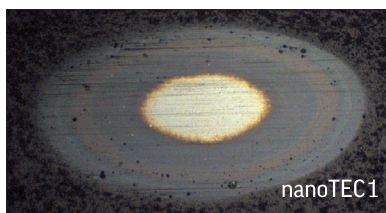

TABLE OF CONTENTS / СОДЕРЖАНИЕ

SOLID CARBIDE TOOLS

ТВЕРДОСПЛАВНЫЙ ИНСТРУМЕНТ

3

1

Carbide mills

Твердосплавные фрезы

5

2

Carbide drills

Твердосплавные сверла

39

3

Special tools

Специальные инструменты

49

TOOLS WITH CARBIDE INSERTS

ИНСТРУМЕНТ СО СМЕННЫМИ ТВЕРДОСПЛАВНЫМИ ПЛАСТИНАМИ

54

4

Turning carbide inserts

Токарные твердосплавные пластины

55

5

Toolholders for external turning

Токарные державки для наружной обработки

91

6

Toolholders for internal turning

Токарные державки для внутренней обработки

123

7

Grooving and parting off

Канавка и отрезка

143

8

Threading inserts

Резьбонарезные пластины

175

9

Milling with carbide inserts

Фрезы со сменными твердосплавными пластинами

217

10

Drills with carbide inserts

Сверла со сменными пластинами

271



SOLID CARBIDE TOOLS
ТВЕРДОСПЛАВНЫЙ
ИНСТРУМЕНТ

SYMBOL LEGEND / УСЛОВНЫЕ ОБОЗНАЧЕНИЯ

Point angle

Двойной угол в плане

Drilling depth

Глубина сверления

Internal cooling

Внутренний подвод СОЖ

2, 3, 4, 5, 6 Flutes

2, 3, 4, 5, 6 Режущие кромки

Irregular teeth

Неравномерное расположение зубьев

Multiple teeth

Многолезвийный инструмент

Ball nose

Сферические

Corner radius

С радиусной кромкой

Square

Прямоугольные

Chamfer

С фаской

Production radius

Технологический радиус

All directions possible

Возможна обработка по всем направлениям

Contouring and angular plunging

Контурная и угловая обработка

Contouring only

Только контурная обработка

Helix angle

Угол наклона винтовой канавки

Standard

Стандарт

Shank type

Форма хвостовика

Hard metal without coating

Твердый сплав без покрытия

High hardness nanocomposite coating (4000 - 4500 HV)

Нанокompозитное покрытие с повышенной твердостью (4000 - 4500 HV)

Nanocomposite coating with high tensile strength and wear resistance (≈4000 HV)

Нанокompозитное покрытие с высокой прочностью и износостойкостью (≈4000 HV)

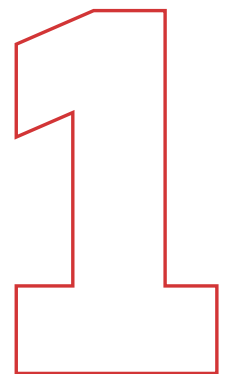

SOLID CARBIDE CUTTING TOOLS
ТВЕРДОСПЛАВНЫЙ ИНСТРУМЕНТ









END MILLS
КОНЦЕВЫЕ ФРЕЗЫ

UMT manufactures generous range of standard carbide milling cutters, including DIN – standard end mills. Combining the know-how and exceptional quality, the UMT milling cutters are delivering optimal machining performance at affordable price.

UMT is also producing and delivering special milling cutters according to customer's requirements.

Компания UMT производит широкий ассортимент стандартных твердосплавных фрез, в том числе и фрез по стандарту DIN. Объединяя ноу-хау и отличное качество, твердосплавные фрезы UMT оптимально обеспечивают обработку различных типов обрабатываемого материала по доступным ценам.

Компания также производит и поставляет специальные твердосплавные фрезы согласно требованиям клиента.

Type / Тип	Size range / Диапазон размеров	Number of flutes / Количество зубьев	Helix angle / Угол наклона винтовой канавки	Code / Код	Shape / Форма	Coating / Покрытие	Work material / Обрабатываемый материал						Page number / Номер страницы				
							P	M	K	N	S	H					
Square / Прямоугольные	Ø3 - Ø20	2	30°	9202		nanoTEC2	●	●	—	●	●	—	—	—	—	10	
	Ø3 - Ø20	3	30°	9203		nanoTEC2	●	●	—	●	●	—	—	—	—	10	
	Ø3 - Ø20	4	30°	9204		nanoTEC2	●	●	—	●	●	—	—	—	—	10	
	Ø3 - Ø16	2	30°	9302		nanoTEC2	●	●	—	●	●	—	—	—	—	12	
	Ø3 - Ø16	4	30°	9304		nanoTEC2	●	●	—	●	●	—	—	—	—	12	
	Ø3 - Ø20	4	36°/38°	9264		nanoTEC2	●	●	○	●	●	—	—	—	—	13	
	NEW Geometry	Ø3 - Ø20	4	36°/38°	9264		nanoTEC2	●	●	○	●	●	—	—	—	—	13
							nanoTEC2	●	●	○	●	●	—	—	—	—	—
Ø6 - Ø20	4	36°/38°	9364		nanoTEC2	●	●	○	●	●	—	—	—	—	14		

● 1st recommend / 1-ый рекомендуемый вариант ○ 2nd recommend / 2-ой рекомендуемый вариант — not recommend / не рекомендуемый вариант

Type / Тип	Size range / Диапазон размеров		Number of flutes / Количество зубьев	Helix angle / Угол наклона винтовой канавки	Code / Код	Shape / Форма	Coating / Покрытие	Work material / Обрабатываемый материал							Page number / Номер страницы					
	Ø3 - Ø20	Ø6 - Ø20						P	M	K	N	S	H							
Square / Прямоугольные	Ø3 - Ø20	Ø3 - Ø20	5	37°	9265		nanoTEC2	●	●	○	●	●	—	—	○	○	○	○	—	15
	Ø6 - Ø20	Ø6 - Ø20	4	36°/38°	9764		nanoTEC1	●	●	○	●	●	—	—	○	○	○	○	—	16
Chamfer 90° / Фасочная 90°	Ø5 - Ø12	Ø5 - Ø12	4	0°	9104		nanoTEC1	●	●	○	●	●	—	—	○	○	○	—	17	
Ball nose / Сферические	Ø3 - Ø20	Ø3 - Ø20	2	30°	9612		nanoTEC1	●	●	○	●	●	—	—	—	—	—	—	—	18
	Ø3 - Ø20	Ø3 - Ø20	4	30°	9614		nanoTEC1	●	●	○	●	●	—	—	—	—	—	—	18	
	Ø3 - Ø20	Ø3 - Ø20	4	39°/42°	9644		nanoTEC2	○	○	●	○	○	—	—	●	●	●	—	19	
Square Corner radius / Прямоугольные с радиусной кромок R0.5-5.0	Ø3 - Ø20	Ø3 - Ø20	4	45°	9224		nanoTEC2	○	○	●	○	○	—	—	○	●	○	—	20	
Square / Прямоугольные	Ø6 - Ø20	Ø6 - Ø20	4	45°	9324		nanoTEC2	○	○	●	○	○	—	—	○	●	○	—	22	
	Ø6 - Ø20	Ø6 - Ø20	3	42°-45°	9243		nanoTEC2	○	○	●	○	○	—	—	○	●	○	—	23	

● 1st recommend / 1-ый рекомендуемый вариант ○ 2nd recommend / 2-ой рекомендуемый вариант — not recommend / не рекомендуемый вариант

Type / Тип	Size range / Диапазон размеров	Number of flutes / Количество зубьев	Helix angle / Угол наклона винтовой канавки	Code / Код	Shape / Форма	Coating / Покрытие	Work material / Обрабатываемый материал						Page number / Номер страницы	
							P	M	K	N	S	H		
Square / Прямоугольные	Ø3 - Ø20	4	39°/42°	9244		nanoTEC2	○	○	●	○	○	—	—	24
Corner radius / С радиусной кромок	Ø6 - Ø20	4	39°/42°	9544		nanoTEC2	○	○	●	○	○	—	—	25
Corner radius / С радиусной кромок	Ø6 - Ø20	4	39°/42°	9554		nanoTEC2	○	○	●	○	○	—	—	26
Corner radius / С радиусной кромок	Ø6 - Ø20	4	39°-42°	9744		nanoTEC2	○	○	●	○	○	—	—	27
Corner radius / С радиусной кромок	Ø3 - Ø20	5	37°	9545		nanoTEC2	○	○	●	○	○	—	—	28
Square / Прямоугольные	Ø6 - Ø20	6	45°	9226		nanoTEC2	○	○	●	○	○	—	—	29
Square / Прямоугольные	Ø6 - Ø20	6	45°	9326		nanoTEC2	○	○	●	○	○	—	—	29
Ball nose / Сферические	Ø6 - Ø16	6-10	50°	9060		nanoTEC1	—	—	—	—	—	—	●	30
Ball nose / Сферические	Ø3 - Ø12	4	30°	9654		nanoTEC1	—	—	—	—	—	—	●	31

● 1st recommend / 1-ый рекомендуемый вариант ○ 2nd recommend / 2-ой рекомендуемый вариант — not recommend / не рекомендуемый вариант

Type / Тип	Size range / Диапазон размеров	Number of flutes / Количество зубьев	Helix angle / Угол наклона винтовой канавки	Code / Код	Shape / Форма	Coating / Покрытие	Work material / Обрабатываемый материал							Page number / Номер страницы				
							P	M	K	N	S	H						
Square / Прямоугольные	Ø3 - Ø20	2	45°	9412		HM	Carbon steel, Alloy steel / Углеродистые стали, Легированные стали	High alloyed steel < 45 HRC / Термообработанные стали < 45 HRC	Stainless steel / Нержавеющие стали	Cast iron / Серый чугун	Nodular cast iron / Высокопрочный чугун	Aluminium alloy / Алюминиевые сплавы	Copper alloy / Медные сплавы	Titanium / Титан	Titanium alloy / Титановые сплавы	Heat resistant alloy / Жаропрочные сплавы	Hardened steel < 60 HRC / Закаленные стали < 60 HRC	32
					3	45°	9413		HM	Carbon steel, Alloy steel / Углеродистые стали, Легированные стали	High alloyed steel < 45 HRC / Термообработанные стали < 45 HRC	Stainless steel / Нержавеющие стали	Cast iron / Серый чугун	Nodular cast iron / Высокопрочный чугун	Aluminium alloy / Алюминиевые сплавы	Copper alloy / Медные сплавы	Titanium / Титан	Titanium alloy / Титановые сплавы
Corner radius / С радиусной кромкой	R0.3-2.0	2	45°	9512		HM	Carbon steel, Alloy steel / Углеродистые стали, Легированные стали	High alloyed steel < 45 HRC / Термообработанные стали < 45 HRC	Stainless steel / Нержавеющие стали	Cast iron / Серый чугун	Nodular cast iron / Высокопрочный чугун	Aluminium alloy / Алюминиевые сплавы	Copper alloy / Медные сплавы	Titanium / Титан	Titanium alloy / Титановые сплавы	Heat resistant alloy / Жаропрочные сплавы	Hardened steel < 60 HRC / Закаленные стали < 60 HRC	32
Ø4 - Ø12					2	45°	9512		HM	Carbon steel, Alloy steel / Углеродистые стали, Легированные стали	High alloyed steel < 45 HRC / Термообработанные стали < 45 HRC	Stainless steel / Нержавеющие стали	Cast iron / Серый чугун	Nodular cast iron / Высокопрочный чугун	Aluminium alloy / Алюминиевые сплавы	Copper alloy / Медные сплавы	Titanium / Титан	Titanium alloy / Титановые сплавы
Square / Прямоугольные	Ø3 - Ø16	2	45°	9422		HM	Carbon steel, Alloy steel / Углеродистые стали, Легированные стали	High alloyed steel < 45 HRC / Термообработанные стали < 45 HRC	Stainless steel / Нержавеющие стали	Cast iron / Серый чугун	Nodular cast iron / Высокопрочный чугун	Aluminium alloy / Алюминиевые сплавы	Copper alloy / Медные сплавы	Titanium / Титан	Titanium alloy / Титановые сплавы	Heat resistant alloy / Жаропрочные сплавы	Hardened steel < 60 HRC / Закаленные стали < 60 HRC	34
					3	45°	9423		HM	Carbon steel, Alloy steel / Углеродистые стали, Легированные стали	High alloyed steel < 45 HRC / Термообработанные стали < 45 HRC	Stainless steel / Нержавеющие стали	Cast iron / Серый чугун	Nodular cast iron / Высокопрочный чугун	Aluminium alloy / Алюминиевые сплавы	Copper alloy / Медные сплавы	Titanium / Титан	Titanium alloy / Титановые сплавы
Square Corner radius / Прямоугольные с радиусной кромкой	R0.5-3.0	3	45°	9453		HM	Carbon steel, Alloy steel / Углеродистые стали, Легированные стали	High alloyed steel < 45 HRC / Термообработанные стали < 45 HRC	Stainless steel / Нержавеющие стали	Cast iron / Серый чугун	Nodular cast iron / Высокопрочный чугун	Aluminium alloy / Алюминиевые сплавы	Copper alloy / Медные сплавы	Titanium / Титан	Titanium alloy / Титановые сплавы	Heat resistant alloy / Жаропрочные сплавы	Hardened steel < 60 HRC / Закаленные стали < 60 HRC	35
Ø6 - Ø20					3	45°	9453		HM	Carbon steel, Alloy steel / Углеродистые стали, Легированные стали	High alloyed steel < 45 HRC / Термообработанные стали < 45 HRC	Stainless steel / Нержавеющие стали	Cast iron / Серый чугун	Nodular cast iron / Высокопрочный чугун	Aluminium alloy / Алюминиевые сплавы	Copper alloy / Медные сплавы	Titanium / Титан	Titanium alloy / Титановые сплавы
Ball nose / Сферические	Ø3 - Ø20	2	45°	9652		HM	Carbon steel, Alloy steel / Углеродистые стали, Легированные стали	High alloyed steel < 45 HRC / Термообработанные стали < 45 HRC	Stainless steel / Нержавеющие стали	Cast iron / Серый чугун	Nodular cast iron / Высокопрочный чугун	Aluminium alloy / Алюминиевые сплавы	Copper alloy / Медные сплавы	Titanium / Титан	Titanium alloy / Титановые сплавы	Heat resistant alloy / Жаропрочные сплавы	Hardened steel < 60 HRC / Закаленные стали < 60 HRC	36
Ø3 - Ø20					2	45°	9652		HM	Carbon steel, Alloy steel / Углеродистые стали, Легированные стали	High alloyed steel < 45 HRC / Термообработанные стали < 45 HRC	Stainless steel / Нержавеющие стали	Cast iron / Серый чугун	Nodular cast iron / Высокопрочный чугун	Aluminium alloy / Алюминиевые сплавы	Copper alloy / Медные сплавы	Titanium / Титан	Titanium alloy / Титановые сплавы

● 1st recommend / 1-ый рекомендуемый вариант ○ 2nd recommend / 2-ой рекомендуемый вариант — not recommend / не рекомендуемый вариант

UMT 9202 Z=2

End mills

Концевые фрезы

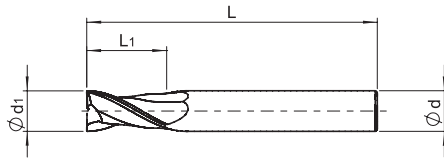
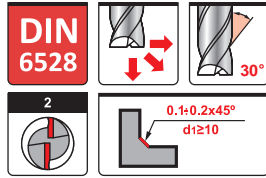

d1 (e8)	L1	d (h6)	L	Stock	ART No	nano TEC2
3	7	3	38	●	9202030003800-2	
4	8	4	50	●	9202040005000-2	
5	10	5	50	●	9202050005000-2	
6	10	6	57	●	9202060005700-2	
8	16	8	63	●	9202080006300-2	
10	19	10	72	●	9202100007200-2	
12	22	12	83	●	9202120008300-2	
14	22	14	83	●	9202140008300-2	
16	26	16	92	●	9202160009200-2	
18	26	18	92	●	9202180009200-2	
20	32	20	104	●	9202200010400-2	

● In stock / В наличии

UMT 9203 Z=3

End mills

Концевые фрезы

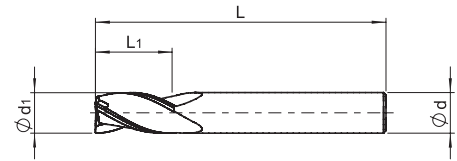
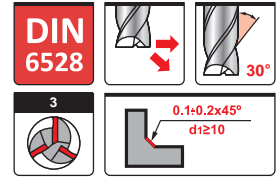

d1 (e8)	L1	d (h6)	L	Stock	ART No	nano TEC2
3	7	3	38	●	9203030003800-2	
4	8	4	50	●	9203040005000-2	
5	10	5	50	●	9203050005000-2	
6	10	6	57	●	9203060005700-2	
8	16	8	63	●	9203080006300-2	
10	19	10	72	●	9203100007200-2	
12	22	12	83	●	9203120008300-2	
14	22	14	83	●	9203140008300-2	
16	26	16	92	●	9203160009200-2	
18	26	18	92	●	9203180009200-2	
20	32	20	104	●	9203200010400-2	

● In stock / В наличии

UMT 9204 Z=4

End mills

Концевые фрезы

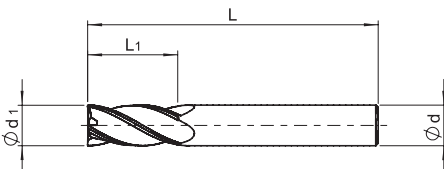
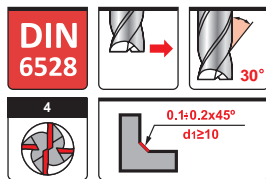

d1 (e8)	L1	d (h6)	L	Stock	ART No	nano TEC2
3	10	3	38	●	9204030003800-2	
4	11	4	50	●	9204040005000-2	
5	13	5	50	●	9204050005000-2	
6	13	6	57	●	9204060005700-2	
8	19	8	63	●	9204080006300-2	
10	22	10	72	●	9204100007200-2	
12	26	12	83	●	9204120008300-2	
14	26	14	83	●	9204140008300-2	
16	32	16	92	●	9204160009200-2	
18	32	18	92	●	9204180009200-2	
20	38	20	104	●	9204200010400-2	

● In stock / В наличии

Recommended cutting conditions for end mills 9202, 9203, 9204 - Shoulder milling

Рекомендуемые режимы резания для фрез 9202, 9203, 9204 - Обработка уступов

Work material Обрабатываемый материал			Cutting speed Скорость резания V_c (m/min)	d_1 - diameter in mm d_1 - диаметр инструмента мм					
	A_p	A_e		$\varnothing 3 - \varnothing 6$	$\varnothing 6 - \varnothing 8$	$\varnothing 8 - \varnothing 10$	$\varnothing 10 - \varnothing 14$	$\varnothing 14 - \varnothing 16$	$\varnothing 16 - \varnothing 20$
P Carbon steel and Alloy steel < 25 HRC Углеродистые, Легированные стали, твердостью < 25 HRC	<1d ₁	<0.2d ₁	nanoTEC2 70-90	0.01-0.025	0.03-0.04	0.035-0.05	0.04-0.06	0.05-0.07	0.06-0.09
Alloy steel and Tool steel 25-45 HRC Легированные, Инструментальные стали, твердостью 25-45 HRC	<1d ₁	<0.1d ₁	30-50	0.01-0.02	0.03-0.04	0.035-0.05	0.04-0.06	0.05-0.07	0.06-0.09
M Stainless steel Нержавеющие стали	<1d ₁	<0.1d ₁	40-60	0.01-0.02	0.025-0.04	0.03-0.04	0.04-0.06	0.05-0.07	0.06-0.08
K Cast iron GG Серый чугун GG	<1d ₁	<0.2d ₁	100-120	0.01-0.025	0.03-0.04	0.035-0.05	0.04-0.06	0.05-0.07	0.06-0.09
Nodular cast iron GGG Высокопрочный чугун GGG	<1d ₁	<0.2d ₁	80-100	0.01-0.02	0.03-0.04	0.035-0.05	0.04-0.06	0.05-0.07	0.06-0.09

Recommended cutting conditions for end mills 9202, 9203 - Slotting

Рекомендуемые режимы резания для фрез 9202, 9203 - Обработка пазов

Work material Обрабатываемый материал			Cutting speed Скорость резания V_c (m/min)	d_1 - diameter in mm d_1 - диаметр инструмента мм					
	A_p			$\varnothing 3 - \varnothing 6$	$\varnothing 6 - \varnothing 8$	$\varnothing 8 - \varnothing 10$	$\varnothing 10 - \varnothing 14$	$\varnothing 14 - \varnothing 16$	$\varnothing 16 - \varnothing 20$
P Carbon steel and Alloy steel < 25 HRC Углеродистые, Легированные стали, твердостью < 25 HRC	<0.5d ₁		nanoTEC2 60-80	0.008-0.02	0.018-0.04	0.02-0.05	0.025-0.06	0.03-0.07	0.04-0.08
Alloy steel and Tool steel 25-45 HRC Легированные, Инструментальные стали, твердостью 25-45 HRC	<0.2d ₁		25-45	0.006-0.018	0.015-0.03	0.02-0.04	0.02-0.05	0.025-0.06	0.03-0.07
M Stainless steel Нержавеющие стали	<0.2d ₁		30-50	0.006-0.02	0.015-0.03	0.02-0.04	0.03-0.07	0.025-0.06	0.03-0.07
K Cast iron GG Серый чугун GG	<0.5d ₁		90-110	0.01-0.025	0.02-0.05	0.025-0.07	0.026-0.07	0.035-0.08	0.035-0.11
Nodular cast iron GGG Высокопрочный чугун GGG	<0.3d ₁		70-90	0.01-0.02	0.02-0.04	0.02-0.06	0.02-0.05	0.027-0.07	0.03-0.10

UMT 9302 Z=2

Long end mills

Удлиненные концевые фрезы

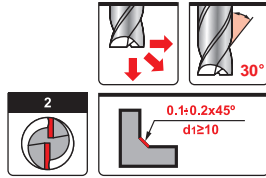

UMT 9304 Z=4

Long end mills

Удлиненные концевые фрезы

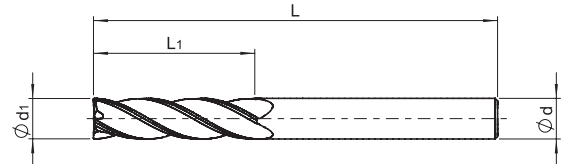
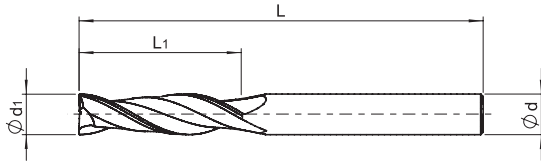
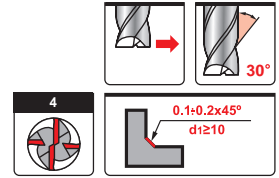

d1 (e8)	L1	d (h6)	L	Stock	ART No	nano TEC2
3	18	3	60	●	9302030006000-2	
4	24	4	60	●	9302040006000-2	
5	26	5	75	●	9302050007500-2	
6	30	6	75	●	9302060007500-2	
8	30	8	75	●	9302080007500-2	
10	40	10	100	●	9302100010000-2	
12	45	12	100	●	9302120010000-2	
16	45	16	100	●	9302160010000-2	

● In stock / В наличии



d1 (e8)	L1	d (h6)	L	Stock	ART No	nano TEC2
3	18	3	60	●	9304030006000-2	
4	24	4	60	●	9304040006000-2	
5	26	5	75	●	9304050007500-2	
6	30	6	75	●	9304060007500-2	
8	30	8	75	●	9304080007500-2	
10	40	10	100	●	9304100010000-2	
12	45	12	100	●	9304120010000-2	
16	45	16	100	●	9304160010000-2	

● In stock / В наличии

Recommended cutting conditions for end mills 9302, 9304 - Shoulder milling

Рекомендуемые режимы резания для фрез 9302, 9304 - Обработка уступов

Work material Обрабатываемый материал	Ap		Cutting speed Скорость резания Vc (m/min)	d1 - diameter in mm d1 - диаметр инструмента мм					fz - feed per tooth in mm fz - подача на зуб мм	
	Ap	Ae		nanoTEC2	Ø3 - Ø6	Ø6 - Ø8	Ø8 - Ø10	Ø10 - Ø12	Ø12 - Ø16	
P Carbon steel and Alloy steel < 25 HRC Углеродистые, Легированные стали, твердостью < 25 HRC	<1d1	<0.1d1	50-60	0.005-0.01	0.01-0.02	0.02-0.03	0.02-0.04	0.03-0.06		
Alloy steel and Tool steel 25-45 HRC Легированные, Инструментальные стали, твердостью 25-45 HRC	<1d1	<0.1d1	30-50	0.005-0.01	0.005-0.01	0.01-0.02	0.01-0.03	0.02-0.05		
M Stainless steel Нержавеющие стали	<1d1	<0.1d1	30-40	0.005-0.01	0.005-0.01	0.01-0.02	0.01-0.03	0.02-0.05		
K Cast iron GG Серый чугун GG	<1d1	<0.1d1	30-70	0.005-0.01	0.01-0.02	0.02-0.03	0.02-0.04	0.03-0.06		
Nodular cast iron GGG Высокопрочный чугун GGG	<1d1	<0.1d1	30-40	0.005-0.01	0.005-0.01	0.01-0.02	0.01-0.03	0.02-0.05		

UMT 9264 Z=4 NEW Geometry

End mills with different helix angles, irregular teeth and relieved neck

Концевые фрезы с переменным углом наклона винтовой канавки, неравномерным расположением зубьев и заниженной шейкой

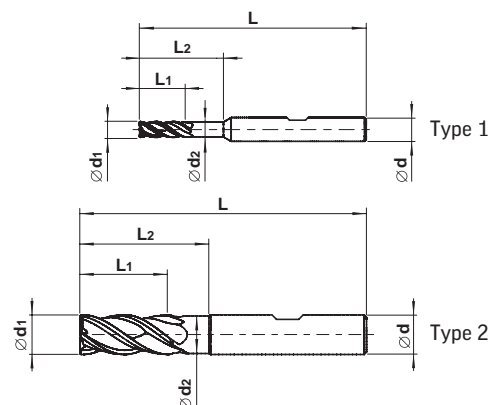
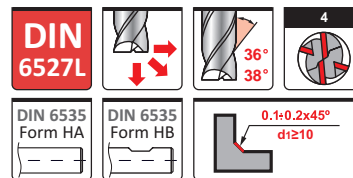

d1 (h10)	L1	L2	d2	d (h6)	L	Type	nano TEC2	
							Stock	ART No
3	8	18	2.8	6	57	1	●	9264030005700-2
4	11	21	3.6	6	57	1	●	9264040005700-2
5	13	21	4.6	6	57	1	●	9264050005700-2
6	13	21	5.5	6	57	2	●	9264060005700-2
8	19	27	7.5	8	63	2	●	9264080006300-2
10	22	32	9.5	10	72	2	●	9264100007200-2
12	26	38	11.5	12	83	2	●	9264120008300-2
14	26	38	13.5	14	83	2	○	9264140008300-2
16	32	44	15.5	16	92	2	●	9264160009200-2
18	32	44	17.5	18	92	2	○	9264180009200-2
20	38	54	19.5	20	104	2	●	9264200010400-2

- In stock / В наличии
- Produced to order only / Изготовление по запросу

Recommended cutting conditions for end mills 9264 - Shoulder milling and slotting
 Рекомендуемые режимы резания для фрез 9264 - Обработка уступов и пазов

Work material Обрабатываемый материал	Cutting speed Скорость резания		Cutting speed Скорость резания		d1 - diameter in mm d1 - диаметр инструмента мм		fz - feed per tooth in mm fz - подача на зуб мм				
	Ap Ae	Vc (m/min)	Ap Ae	Vc (m/min)	nanoTEC2		nanoTEC2				
P Carbon steel and Alloy steel < 25 HRC Углеродистые, Легированные стали, твердостью < 25 HRC	<2d1	<0.5d1	140-180	<1d1 max 12mm	120-160	0.015-0.03	0.025-0.04	0.035-0.05	0.045-0.075	0.065-0.09	0.07-0.11
Alloy steel and Tool steel 25-45 HRC Легированные, Инструментальные стали, твердостью 25-45 HRC	<2d1	<0.4d1	110-140	<0.7d1 max 12mm	90-120	0.015-0.03	0.025-0.04	0.035-0.05	0.045-0.075	0.065-0.09	0.07-0.11
M Нержавеющие стали Stainless steel	<1.5d1	<0.3d1	45-55	<0.5d1	35-45	0.01-0.025	0.02-0.035	0.03-0.045	0.04-0.07	0.045-0.08	0.055-0.10
K Stainless steel Нержавеющие стали	<2d1	<0.5d1	100-120	<1d1 max 12mm	90-110	0.015-0.03	0.025-0.04	0.035-0.05	0.045-0.075	0.065-0.09	0.07-0.11
Cast iron GG Серый чугун GG	<2d1	<0.4d1	90-110	<1d1 max 12mm	80-100	0.015-0.03	0.025-0.04	0.035-0.05	0.045-0.075	0.065-0.09	0.07-0.11

1. The figures to be adjusted according to machining shape, rigidity of machine and work clamping
 2. For high alloyed steels (>12% Cr), INOX, cutting speed must be reduced by 20-30% when used emulsion
 1. Вышеприведенные режимы указаны для жесткой технологической системы
 2. Для высоколегированных сталей (>12% Cr) и нержавеющей сталей, скорость резания должна быть уменьшена на 20-30% при использовании эмульсии

UMT 9364 Z=4

Long end mills with different helix angles, irregular teeth and relieved neck

Удлиненные концевые фрезы с переменным углом наклона винтовой канавки, неравномерным расположением зубьев и заниженной шейкой

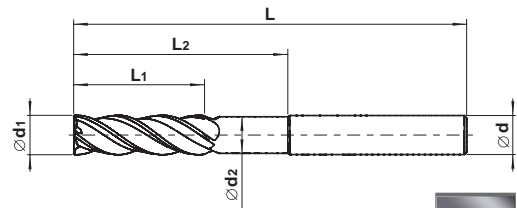
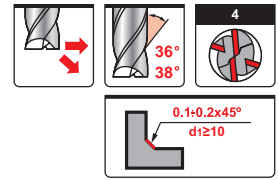

**nano
TEC2**

d1 (h10)	L1	L2	d2	d (h6)	L	Stock	ART No
6	19	29	5.5	6	63	●	9364060006300-2
8	26	42	7.5	8	80	●	9364080008000-2
10	33	54	9.5	10	100	●	9364100010000-2
12	38	54	11.5	12	100	●	9364120010000-2
16	53	69	15.5	16	150	●	9364160015000-2
20	68	84	19.5	20	150	●	9364200015000-2

● In stock / В наличии

Recommended cutting conditions for end mills 9364 - Shoulder

Рекомендуемые режимы резания для фрез 9364 - Обработка уступов

Work material Обрабатываемый материал	Ap Ae		Cutting speed Скорость резания Vc (m/min)	d1 - diameter in mm d1 - диаметр инструмента мм					
	Ap	Ae		ø6	ø8	ø10	ø12	ø16	ø20
P Carbon steel and Alloy steel < 25 HRC Углеродистые, Легированные стали, твердостью < 25 HRC	<2d1	<0.4d1	130-170	0.02-0.035	0.035-0.045	0.045-0.06	0.06-0.075	0.07-0.09	0.08-0.10
Alloy steel and Tool steel 25-45 HRC Легированные, Инструментальные стали, твердостью 25-45 HRC	<2d1	<0.3d1	100-130	0.02-0.035	0.035-0.045	0.045-0.06	0.06-0.075	0.07-0.09	0.08-0.10
M Stainless steel Нержавеющие стали	<1.5d1	<0.2d1	35-45	0.015-0.03	0.03-0.04	0.04-0.055	0.055-0.07	0.065-0.08	0.075-0.09
K Cast iron GG Серый чугун GG	<2d1	<0.4d1	90-110	0.02-0.035	0.035-0.045	0.045-0.06	0.06-0.075	0.07-0.09	0.08-0.10
Nodular cast iron GGG Высокопрочный чугун GGG	<2d1	<0.3d1	80-100	0.02-0.035	0.035-0.045	0.045-0.06	0.06-0.075	0.07-0.09	0.08-0.10

1. The figures to be adjusted according to machining shape, rigidity of machine and work clamping

2. For high alloyed steels (>12% Cr), INOX, cutting speed must be reduced by 20-30% when used emulsion

1. Вышеприведенные режимы указаны для жесткой технологической системы

2. Для высоколегированных сталей (>12% Cr) и нержавеющей сталей, скорость резания должна быть уменьшена на 20-30% при использовании эмульсии

UMT 9265 Z=5

HPC end mills with irregular teeth for machining different types of steel

Высокопроизводительные концевые фрезы с неравномерным расположением зубьев для динамического фрезерования сталей

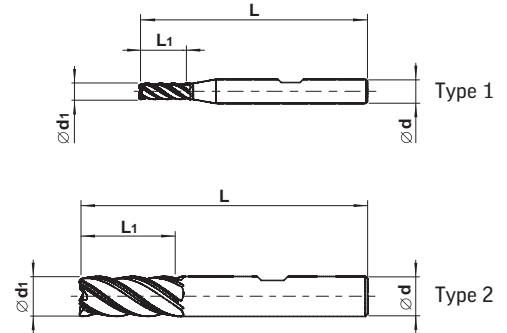
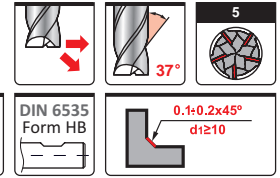

d1 (h10)	L1	d (h6)	L	Type	nanoTEC2		nanoTEC2	
					Stock	ART No	Stock	ART No
					Shank Style DIN 6535 HA		Shank Style DIN 6535 HB	
3	8	6	57	1	●	9265030005700-2	○	9265030005700-2-HB
4	11	6	57	1	●	9265040005700-2	○	9265040005700-2-HB
5	13	6	57	1	●	9265050005700-2	○	9265050005700-2-HB
6	13	6	57	2	●	9265060005700-2	○	9265060005700-2-HB
8	19	8	63	2	●	9265080006300-2	○	9265080006300-2-HB
10	22	10	72	2	○	9265100007200-2	●	9265100007200-2-HB
12	26	12	83	2	○	9265120008300-2	●	9265120008300-2-HB
16	32	16	92	2	○	9265160009200-2	●	9265160009200-2-HB
20	38	20	104	2	○	9265200010400-2	●	9265200010400-2-HB

- In stock / В наличии
- Produced to order only / Изготовление по запросу

Recommended cutting conditions for end mills 9265 - Shoulder milling and slotting

Рекомендуемые режимы резания для фрез 9265 - Обработка уступов и пазов

Work material Обрабатываемый материал	Cutting speed Скорость резания		Cutting speed Скорость резания		d1 - diameter in mm d1 - диаметр инструмента мм					fz - feed per tooth in mm fz - подача на зуб мм				
	Ap	Ae	Vc (m/min)	Vc (m/min)	Ap	Ap	Ap	Ap	Ap	Ap	Ap	Ap	Ap	
P Carbon steel and Alloy steel < 25 HRC Углеродистые, Легированные стали, твердостью < 25 HRC Alloy steel and Tool steel 25-45 HRC Легированные, Инструментальные стали, твердостью 25-45 HRC	<1.5d1	<0.5d1	160-190	<1d1 max 12mm	130-150	0.012	0.018	0.022	0.029	0.049	0.06	0.074	0.087	0.095
	<1.5d1	<0.4d1	90-110	<0.7d1 max 12mm	70-90	0.01	0.015	0.018	0.022	0.036	0.045	0.055	0.067	0.075
M Stainless steel Нержавеющие стали	<1.5d1	<0.3d1	80-100	<0.5d1	60-80	0.008	0.01	0.014	0.017	0.03	0.037	0.043	0.05	0.058
K Cast iron GG Серый чугун GG Nodular cast iron GGG Высокопрочный чугун GGG	<1.5d1	<0.5d1	130-160	<1d1 max 12mm	100-120	0.01	0.015	0.018	0.026	0.045	0.056	0.067	0.079	0.09
	<1.5d1	<0.4d1	110-140	<0.7d1 max 12mm	80-100	0.009	0.012	0.015	0.02	0.034	0.043	0.05	0.059	0.067

- The figures to be adjusted according to machining shape, rigidity of machine and work clamping
- For high alloyed steels (>12% Cr), INOX, cutting speed must be reduced by 20-30% when used emulsion
- Вышеприведенные режимы указаны для жесткой технологической системы
- Для высоколегированных сталей (>12% Cr) и нержавеющей сталей, скорость резания должна быть уменьшена на 20-30% при использовании эмульсии

UMT 9764 Z-4 NEW

HPC Roughing end mills with different helix angles and irregular teeth for machining different types of steel

Высокопроизводительные концевые фрезы с переменным углом наклона винтовой канавки и неравномерным расположением зубьев для черновой обработки сталей

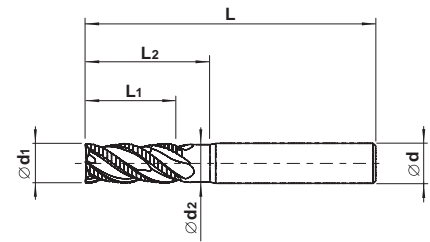
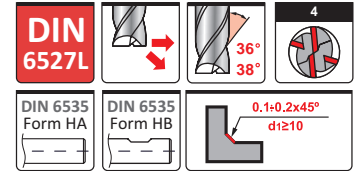

d1 (h10)	L1	L2	d2	d (h6)	L	nano TEC1		nano TEC1	
						Stock	ART No	Stock	ART No
						Shank Style DIN 6535 HA		Shank Style DIN 6535 HB	
6	13	21	5.5	6	57	●	9764060005700-1	○	9764060005700-1-HB
8	19	27	7.5	8	63	●	9764080006300-1	○	9764080006300-1-HB
10	22	32	9.3	10	72	○	9764100007200-1	●	9764100007200-1-HB
12	26	38	11.2	12	83	○	9764120008300-1	●	9764120008300-1-HB
14	26	38	13.2	14	83	○	9764140008300-1	○	9764140008300-1-HB
16	32	44	15.2	16	92	○	9764160009200-1	●	9764160009200-1-HB
18	32	44	17.2	18	92	○	9764180009200-1	○	9764180009200-1-HB
20	38	54	19.2	20	104	○	9764200010400-1	●	9764200010400-1-HB

● In stock / В наличии
○ Produced to order only / Изготовление по запросу

Recommended cutting conditions for end mills 9764 - Shoulder milling and slotting

Рекомендуемые режимы резания для фрез 9764 - Обработка уступов и пазов

Work material Обрабатываемый материал	Cutting speed Скорость резания		Cutting speed Скорость резания		d1 - diameter in mm d1 - диаметр инструмента мм				fz - feed per tooth in mm fz - подача на зуб мм				
	Ap Ae	Vc (m/min)	Ap Ae	Vc (m/min)	ø6	ø8	ø10	ø12	ø14	ø16	ø18	ø20	
P Carbon steel and Alloy steel < 25 HRC Углеродистые, легированные стали твердостью < 25 HRC	<1.8d1	<0.5d1	130-140	<1d1 max 12mm	100-120	0.03	0.04	0.047	0.052	0.058	0.061	0.063	0.067
Alloy steel and Tool steel 25-45 HRC Легированные, инструментальные стали, твердостью 25-45 HRC	<1.8d1	<0.4d1	70-80	<0.7d1 max 12mm	55-75	0.025	0.035	0.042	0.047	0.052	0.055	0.06	0.065
M Stainless steel Нержавеющие стали	<1.8d1	<0.3d1	50-60	<0.5d1	40-50	0.022	0.033	0.04	0.045	0.048	0.052	0.057	0.062
K Cast iron GG Серый чугун GG	<1.8d1	<0.5d1	110-140	<1d1 max 12mm	80-100	0.03	0.04	0.047	0.052	0.058	0.061	0.063	0.067
Nodular cast iron GGG Высокопрочный чугун GGG	<1.8d1	<0.4d1	90-120	<0.7d1 max 12mm	60-80	0.025	0.035	0.042	0.047	0.052	0.055	0.06	0.065

- The figures to be adjusted according to machining shape, rigidity of machine and work clamping
- For high alloyed steels (>12% Cr), INOX, cutting speed must be reduced by 20-30% when used emulsion
- Вышеприведенные режимы указаны для жесткой технологической системы
- Для высоколегированных сталей (>12% Cr) и нержавеющей сталей, скорость резания должна быть уменьшена на 20-30% при использовании эмульсии

UMT 9104 Z=4 NEW

Chamfer end mill 90°

Фреза фасочная 90°

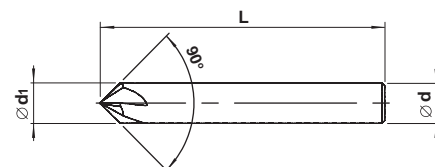
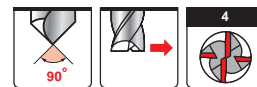

**nano
TEC1**

d1 (h10)	d (h6)	L	Stock	ART No
5	5	50	●	9104050005000-1
6	6	57	●	9104060005700-1
8	8	63	●	9104080006300-1
10	10	65	●	9104100006500-1
12	12	65	●	9104120006500-1

● In stock / В наличии

Recommended cutting conditions for end mills 9104 - Chamfer milling

Рекомендуемые режимы резания для фрез 9104 - Фрезерование фаски

Work material Обрабатываемый материал	Cutting speed Скорость резания V _c (m/min)	d1 - diameter in mm d1 - диаметр инструмента мм			fz - feed per tooth in mm fz - подача на зуб мм	
		Ø5	Ø6	Ø8	Ø10	Ø12
P Carbon steel and Alloy steel < 25 HRC Углеродистые, Легированные стали, твердостью < 25 HRC	110-150	0.025-0.035	0.035-0.045	0.045-0.05	0.05-0.06	0.06-0.07
Alloy steel and Tool steel 25-45 HRC Легированные, Инструментальные стали, твердостью 25-45 HRC	80-110	0.02-0.03	0.03-0.04	0.04-0.045	0.045-0.055	0.055-0.065
M Stainless steel Нержавеющие стали	40-60	0.02-0.03	0.03-0.04	0.04-0.045	0.045-0.055	0.055-0.065
K Cast iron GG Серый чугун GG	70-90	0.025-0.035	0.035-0.045	0.045-0.05	0.05-0.06	0.06-0.07
Nodular cast iron GGG Высокопрочный чугун GGG	60-80	0.02-0.03	0.03-0.04	0.04-0.045	0.045-0.055	0.055-0.065
S Titanium alloy Титановые сплавы	40-50	0.02-0.03	0.03-0.04	0.04-0.045	0.045-0.055	0.055-0.065

For high alloyed steels (> 12 Cr), INOX, titanium alloys, cutting speed must be reduced by 20-30% when used emulsion
Для высоколегированных сталей (> 12 Cr), нержавеющей сталей и титановых сплавов, скорость резания должна быть уменьшена на 20-30% при использовании эмульсии

UMT 9612 Z=2

Ball nose end mills
Сферические фрезы

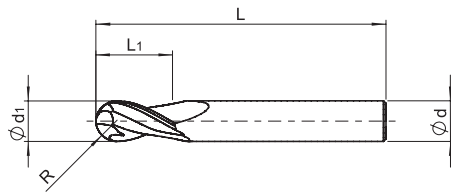
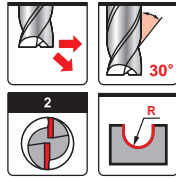

nano
TEC1

d1 (e8)	L1	d (h6)	L	R(d1/2)	Stock	ART No
3	7	3	38	1.5	●	9612030003800-1
4	8	4	50	2.0	●	9612040005000-1
5	10	5	50	2.5	●	9612050005000-1
6	10	6	57	3.0	●	9612060005700-1
8	16	8	63	4.0	●	9612080006300-1
10	19	10	72	5.0	●	9612100007200-1
12	22	12	83	6.0	●	9612120008300-1
14	22	14	83	7.0	●	9612140008300-1
16	26	16	92	8.0	●	9612160009200-1
20	32	20	104	10.0	●	9612200010400-1

● In stock / В наличии

UMT 9614 Z=4

Ball nose end mills
Сферические фрезы

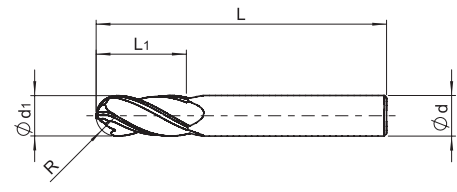
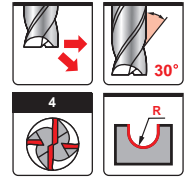

nano
TEC1

d1 (e8)	L1	d (h6)	L	R(d1/2)	Stock	ART No
3	10	3	38	1.5	●	9614030003800-1
4	11	4	50	2.0	●	9614040005000-1
5	13	5	50	2.5	●	9614050005000-1
6	13	6	57	3.0	●	9614060005700-1
8	19	8	63	4.0	●	9614080006300-1
10	22	10	72	5.0	●	9614100007200-1
12	26	12	83	6.0	●	9614120008300-1
14	26	14	83	7.0	●	9614140008300-1
16	32	16	92	8.0	●	9614160009200-1
20	38	20	104	10.0	●	9614200010400-1

● In stock / В наличии

Recommended cutting conditions for end mills 9612, 9614 - Shoulder milling

Рекомендуемые режимы резания для фрез 9612, 9614 - Обработка уступов

Work material Обрабатываемый материал			Cutting speed Скорость резания Vc (m/min)	d1 - diameter in mm d1 - диаметр инструмента мм				fz - feed per tooth in mm fz - подача на зуб мм	
	Ap	Ae		nanoTEC1	Ø3 - Ø4	Ø5 - Ø6	Ø6 - Ø8	Ø8 - Ø10	Ø10 - Ø14
P Carbon steel and Alloy steel < 25 HRC Углеродистые, Легированные стали, твердостью < 25 HRC	<0.1d1	<0.2d1	80-90	0.005-0.01	0.01-0.02	0.015-0.03	0.03-0.04	0.04-0.07	0.04-0.07
Alloy steel and Tool steel 25-45 HRC Легированные, Инструментальные стали, твердостью 25-45 HRC	<0.1d1	<0.1d1	50-70	0.004-0.01	0.01-0.02	0.015-0.03	0.03-0.04	0.04-0.06	0.04-0.06
M Stainless steel Нержавеющие стали	<0.1d1	<0.1d1	25-35	0.004-0.01	0.01-0.02	0.015-0.03	0.03-0.04	0.04-0.06	0.04-0.06
K Cast iron GG Серый чугун GG	<0.1d1	<0.2d1	80-90	0.005-0.01	0.01-0.02	0.015-0.03	0.03-0.04	0.04-0.07	0.04-0.07
Nodular cast iron GGG Высокопрочный чугун GGG	<0.1d1	<0.2d1	70-80	0.004-0.01	0.01-0.02	0.015-0.03	0.03-0.04	0.04-0.06	0.04-0.06

UMT 9644 Z=4

Ball nose end mills with different helix angles and irregular teeth for difficult to cut materials

Сферические фрезы с переменным углом наклона винтовой канавки и неравномерным расположением зубьев для труднообрабатываемых материалов

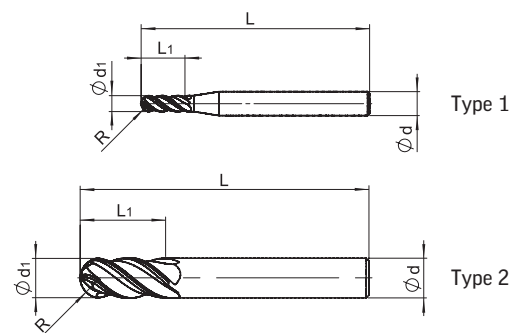
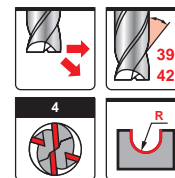

d1 (e8)	L1	d (h6)	L	R (d1/2)	Stock	Type	ART No
3	8	6	57	1.5	●	1	9644030005700-2
4	11	6	57	2.0	●	1	9644040005700-2
5	13	6	57	2.5	●	1	9644050005700-2
6	13	6	57	3.0	●	2	9644060005700-2
8	19	8	63	4.0	●	2	9644080006300-2
10	22	10	72	5.0	●	2	9644100007200-2
12	26	12	83	6.0	●	2	9644120008300-2
16	32	16	92	8.0	○	2	9644160009200-2
20	38	20	104	10.0	○	2	9644200010400-2

nanoTEC2

● In stock / В наличии
○ Produced to order only / Изготовление по запросу

Recommended cutting conditions for end mills 9644 Рекомендуемые режимы резания для фрез 9644

Work material Обрабатываемый материал	Cutting speed Скорость резания V _c (m/min)		d ₁ - diameter in mm d ₁ - диаметр инструмента мм							f _z - feed per tooth in mm f _z - подача на зуб мм		
	Ap	Ae	nanoTEC2	Ø3	Ø4	Ø5	Ø6	Ø8	Ø10	Ø12	Ø16	Ø20
P Carbon steel and Alloy steel < 25 HRC Углеродистые, Легированные стали, твердостью < 25 HRC	<0.2d ₁	<0.3d ₁	110-130	0.02	0.025	0.03	0.035	0.05	0.06	0.065	0.075	0.09
Alloy steel and Tool steel 25-45 HRC Легированные, Инструментальные стали, твердостью 25-45 HRC	<0.2d ₁	<0.3d ₁	60-80	0.015	0.02	0.025	0.028	0.04	0.048	0.052	0.06	0.07
M Stainless steel Нержавеющие стали	<0.15d ₁	<0.2d ₁	55-75	0.015	0.02	0.025	0.028	0.04	0.048	0.052	0.06	0.07
S Titanium alloy Титановые сплавы	<0.15d ₁	<0.2d ₁	55-75	0.015	0.02	0.025	0.028	0.04	0.048	0.052	0.06	0.07
Titanium Титан	<0.1d ₁	<0.2d ₁	40-60	0.012	0.015	0.018	0.02	0.03	0.035	0.04	0.05	0.06
Heat resistant alloy Жаропрочные сплавы	<0.1d ₁	<0.1d ₁	25-35	0.01	0.012	0.015	0.018	0.025	0.032	0.038	0.046	0.055

1. The figures to be adjusted according to machining shape, rigidity of machine and work clamping
2. For high alloyed steels (> 12% Cr), INOX, cutting speed must be reduced by 20-30% when used emulsion
1. Вышеприведенные режимы указаны для жесткой технологической системы
2. Для высоколегированных сталей (> 12% Cr) и нержавеющей сталей, скорость резания должна быть уменьшена на 20-30% при использовании эмульсии

UMT 9224 Z-4

End mills

Концевые фрезы

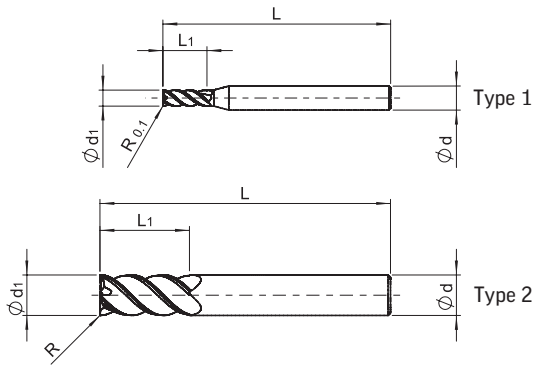
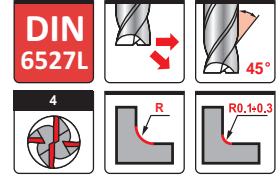

nano
TEC2

d1 (e8)	L1	d (h6)	L	R(±0.02)	Stock	Type	ART No
3	10	3	38		●	2	9224030003800-2
3	8	6	57		●	1	9224030005700-2
4	11	4	50		●	2	9224040005000-2
4	11	6	57		●	1	9224040005700-2
5	13	5	50		●	2	9224050005000-2
5	13	6	57		●	1	9224050005700-2
6	13	6	57		●	2	9224060005700-2
6	13	6	57	0.5	○	2	9224060005705-2
6	13	6	57	1.0	○	2	9224060005710-2
6	13	6	57	1.5	○	2	9224060005715-2
8	19	8	63		●	2	9224080006300-2
8	19	8	63	0.5	○	2	9224080006305-2
8	19	8	63	1.0	○	2	9224080006310-2
8	19	8	63	1.5	○	2	9224080006315-2
10	22	10	72		●	2	9224100007200-2
10	22	10	72	0.5	○	2	9224100007205-2
10	22	10	72	1.0	○	2	9224100007210-2
10	22	10	72	1.5	○	2	9224100007215-2
10	22	10	72	2.0	○	2	9224100007220-2
12	26	12	83		●	2	9224120008300-2
12	26	12	83	0.5	○	2	9224120008305-2
12	26	12	83	1.0	○	2	9224120008310-2
12	26	12	83	1.5	○	2	9224120008315-2
12	26	12	83	2.0	○	2	9224120008320-2
12	26	12	83	3.0	○	2	9224120008330-2
14	26	14	83		●	2	9224140008300-2
16	32	16	92		●	2	9224160009200-2
16	32	16	92	1.5	○	2	9224160009215-2
16	32	16	92	2.0	○	2	9224160009220-2
16	32	16	92	3.0	○	2	9224160009230-2
16	32	16	92	4.0	○	2	9224160009240-2
18	32	18	92		●	2	9224180009200-2
20	38	20	104		●	2	9224200010400-2
20	38	20	104	3.0	○	2	9224200010430-2
20	38	20	104	4.0	○	2	9224200010440-2
20	38	20	104	5.0	○	2	9224200010450-2

● In stock / В наличии

○ Produced to order only / Изготовление по запросу

Recommended cutting conditions for end mills 9224 - Shoulder milling

Рекомендуемые режимы резания для фрез 9224 - Обработка уступов

Work material Обрабатываемый материал			Cutting speed Скорость резания V _c (m/min)	d ₁ - diameter in mm d ₁ - диаметр инструмента мм						f _z - feed per tooth in mm f _z - подача на зуб мм	
	Ap	Ae		nanoTEC2	Ø3 - Ø6	Ø6 - Ø8	Ø8 - Ø10	Ø10 - Ø14	Ø14 - Ø16	Ø16 - Ø20	
P Carbon steel and Alloy steel < 25 HRC Углеродистые, Легированные стали, твердостью < 25 HRC Alloy steel and Tool steel 25-45 HRC Легированные, Инструментальные стали, твердостью 25-45 HRC	<1.5d ₁	<0.2d ₁	90-100	0.01-0.03	0.03-0.06	0.04-0.08	0.045-0.10	0.06-0.12	0.07-0.14		
	<1.5d ₁	<0.2d ₁	40-60	0.01-0.02	0.025-0.05	0.035-0.065	0.04-0.08	0.045-0.08	0.055-0.10		
M Stainless steel Нержавеющие стали	<1.5d ₁	<0.1d ₁	50-60	0.01-0.02	0.025-0.05	0.035-0.065	0.04-0.08	0.045-0.08	0.055-0.10		
K Cast iron GG Серый чугун GG Nodular cast iron GGG Высокопрочный чугун GGG	<1.5d ₁	<0.2d ₁	90-110	0.01-0.03	0.03-0.06	0.04-0.08	0.045-0.10	0.06-0.12	0.07-0.14		
	<1.5d ₁	<0.1d ₁	80-100	0.01-0.02	0.025-0.05	0.035-0.065	0.04-0.08	0.045-0.08	0.055-0.10		
S Titanium alloy Титановые сплавы	<1.5d ₁	<0.1d ₁	50-60	0.01-0.02	0.025-0.05	0.035-0.065	0.04-0.08	0.045-0.08	0.055-0.10		

For high alloyed steel (> 12% Cr), INOX, titanium alloy, cutting speed must be reduced by 20-30% when used emulsion
 Для высоколегированных сталей (> 12% Cr), нержавеющей сталей и титановых сплавов, скорость резания должна быть уменьшена на 20-30% при использовании эмульсии

Recommended cutting conditions for end mills 9224 - Slotting

Рекомендуемые режимы резания для фрез 9224 - Обработка пазов

Work material Обрабатываемый материал			Cutting speed Скорость резания V _c (m/min)	d ₁ - diameter in mm d ₁ - диаметр инструмента мм						f _z - feed per tooth in mm f _z - подача на зуб мм	
	Ap			nanoTEC2	Ø3 - Ø6	Ø6 - Ø8	Ø8 - Ø10	Ø10 - Ø14	Ø14 - Ø16	Ø16 - Ø20	
P Carbon steel and Alloy steel < 25 HRC Углеродистые, Легированные стали, твердостью < 25 HRC Alloy steel and Tool steel 25-45 HRC Легированные, Инструментальные стали, твердостью 25-45 HRC	<1d ₁		70-80	0.008-0.02	0.018-0.04	0.02-0.05	0.025-0.06	0.03-0.07	0.04-0.08		
	<1d ₁		30-50	0.006-0.018	0.015-0.03	0.02-0.04	0.02-0.05	0.025-0.06	0.03-0.07		
M Stainless steel Нержавеющие стали	<0.5d ₁		40-50	0.006-0.02	0.015-0.03	0.02-0.04	0.02-0.05	0.025-0.06	0.03-0.07		
K Cast iron GG Серый чугун GG Nodular cast iron GGG Высокопрочный чугун GGG	<1d ₁		90-110	0.01-0.025	0.02-0.05	0.025-0.07	0.03-0.07	0.035-0.08	0.035-0.11		
	<1d ₁		80-100	0.01-0.02	0.02-0.04	0.02-0.06	0.026-0.07	0.027-0.07	0.03-0.10		
S Titanium alloy Титановые сплавы	<0.5d ₁		40-50	0.003-0.015	0.005-0.04	0.008-0.04	0.01-0.05	0.015-0.06	0.015-0.08		

For high alloyed steel (> 12% Cr), INOX, titanium alloy, cutting speed must be reduced by 20-30% when used emulsion
 Для высоколегированных сталей (> 12% Cr), нержавеющей сталей и титановых сплавов, скорость резания должна быть уменьшена на 20-30% при использовании эмульсии

UMT 9324 Z=4

Long end mills

Удлиненные концевые фрезы

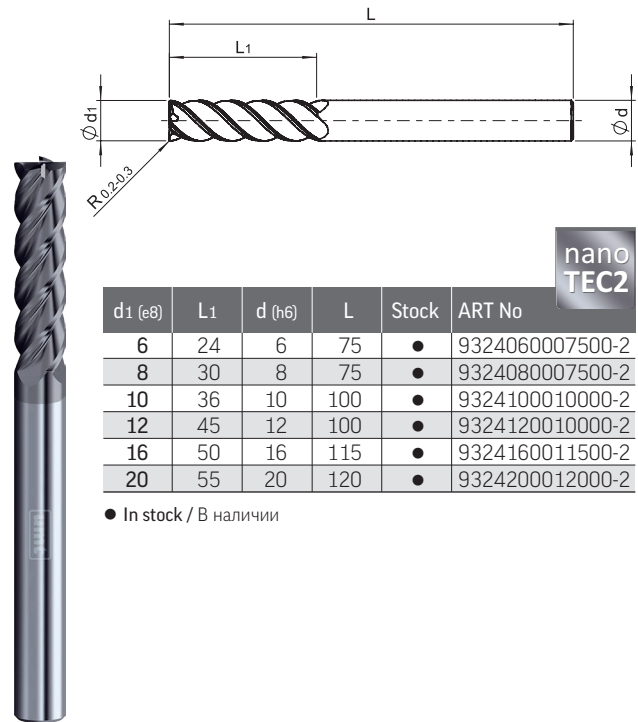
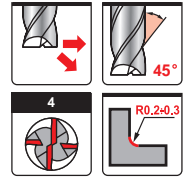

nano
TEC2

d1 (e8)	L1	d (h6)	L	Stock	ART No
6	24	6	75	●	9324060007500-2
8	30	8	75	●	9324080007500-2
10	36	10	100	●	9324100010000-2
12	45	12	100	●	9324120010000-2
16	50	16	115	●	9324160011500-2
20	55	20	120	●	9324200012000-2

● In stock / В наличии

Recommended cutting conditions for end mills 9324 - Shoulder milling
 Рекомендуемые режимы резания для фрез 9324 - Обработка уступов

Work material Обрабатываемый материал			Cutting speed Скорость резания Vc (m/min)	d1 - diameter in mm d1 - диаметр инструмента мм					
	Ap	Ae		ø6	ø8	ø10	ø12	ø16	ø20
P Carbon steel and Alloy steel < 25 HRC Углеродистые, Легированные стали, твердостью < 25 HRC	<2.5d1	<0.05d1	70-80	0.03-0.04	0.05-0.06	0.06-0.07	0.07-0.08	0.08-0.09	0.09-0.10
Alloy steel and Tool steel 25-45 HRC Легированные, Инструментальные стали, твердостью 25-45 HRC	<2d1	<0.05d1	40-50	0.025-0.035	0.045-0.055	0.05-0.06	0.06-0.07	0.07-0.08	0.08-0.09
M Stainless steel Нержавеющие стали	<2d1	<0.02d1	40-50	0.025-0.035	0.045-0.055	0.05-0.06	0.06-0.065	0.065-0.07	0.07-0.08
K Cast iron GG Серый чугун GG	<2.5d1	<0.05d1	90-110	0.03-0.04	0.05-0.06	0.06-0.07	0.07-0.08	0.08-0.09	0.09-0.10
Nodular cast iron GGG Высокопрочный чугун GGG	<2.5d1	<0.05d1	80-100	0.03-0.04	0.05-0.06	0.06-0.07	0.07-0.08	0.08-0.09	0.09-0.10
S Titanium alloy Титановые сплавы	<2d1	<0.02d1	40-50	0.025-0.035	0.045-0.055	0.05-0.06	0.06-0.065	0.065-0.07	0.07-0.08

For high alloyed steel (> 12% Cr), INOX, titanium alloy, cutting speed must be reduced by 20-30% when used emulsion
 Для высоколегированных сталей (>12% Cr), нержавеющей сталей и титановых сплавов, скорость резания должна быть уменьшена на 20-30% при использовании эмульсии

UMT 9243 Z=3 NEW

End mills with different helix angles, irregular teeth and relieved neck

Концевые фрезы с переменным углом наклона винтовой канавки, неравномерным расположением зубьев и заниженной шейкой

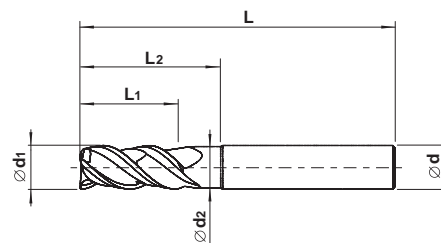
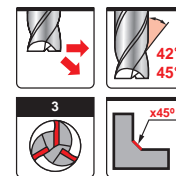

nano
TEC2

d1 (h10)	L1	L2	d2	d (h6)	L	Stock	ART No
6	13	21	5.5	6	57	●	9243060005700-2
8	19	27	7.5	8	63	●	9243080006300-2
10	22	32	9.5	10	72	●	9243100007200-2
12	26	38	11.5	12	83	●	9243120008300-2
14	26	38	13.5	14	83	●	9243140008300-2
16	32	44	15.5	16	92	●	9243160009200-2
18	32	44	17.5	18	92	○	9243180009200-2
20	38	54	19.5	20	104	●	9243200010400-2

● In stock / В наличии

○ Produced to order only / Изготовление по запросу

Recommended cutting conditions for end mills 9243 - Shoulder milling and slotting

Рекомендуемые режимы резания для фрез 9243 - Обработка уступов и пазов

Work material Обрабатываемый материал	Cutting speed Скорость резания		Vc (m/min)	Cutting speed Скорость резания		d1 - diameter in mm d1 - диаметр инструмента мм				fz - feed per tooth in mm fz - подача на зуб мм			
	Ap Ae	Ap Ae		Ap Ae	Vc (m/min)	Ap	Ae	Ap	Ae	Ap	Ae	Ap	Ae
P Carbon steel and Alloy steel < 25 HRC Углеродистые, легированные стали твердостью < 25 HRC	<1.5d1	<0.5d1	100-160	<1d1 max 12mm	90-130	0.029	0.049	0.061	0.074	0.086	0.10	0.103	0.107
Alloy steel and Tool steel 25-45 HRC Легированные, инструментальные стали, твердостью 25-45 HRC	<1.5d1	<0.4d1	60-90	<0.7d1 max 12mm	50-80	0.022	0.036	0.045	0.055	0.063	0.074	0.077	0.08
M Stainless steel Нержавеющие стали	<1.5d1	<0.3d1	60-90	<0.7d1 max 12mm	50-80	0.019	0.032	0.04	0.048	0.056	0.064	0.066	0.069
K Cast iron GG Серый чугун GG	<1.5d1	<0.5d1	90-120	<1d1 max 12mm	70-100	0.029	0.049	0.061	0.074	0.086	0.10	0.103	0.107
Nodular cast iron GGG Высокопрочный чугун GGG	<1.5d1	<0.4d1	70-100	<0.7d1 max 12mm	50-80	0.022	0.036	0.045	0.055	0.063	0.074	0.077	0.08
S Titanium alloy Титановые сплавы	<1.5d1	<0.4d1	40-60	<0.7d1 max 12mm	35-50	0.019	0.032	0.04	0.048	0.056	0.064	0.066	0.069

1. The figures to be adjusted according to machining shape, rigidity of machine and work clamping

2. For high alloyed steels (> 12% Cr), INOX, cutting speed must be reduced by 20-30% when used emulsion

1. Вышеприведенные режимы указаны для жесткой технологической системы

2. Для высоколегированных сталей (> 12% Cr) и нержавеющей сталей, скорость резания должна быть уменьшена на 20-30% при использовании эмульсии

UMT 9244 Z=4

End mills with different helix angles and irregular teeth
 Концевые фрезы с переменным углом наклона винтовой канавки и неравномерным расположением зубьев

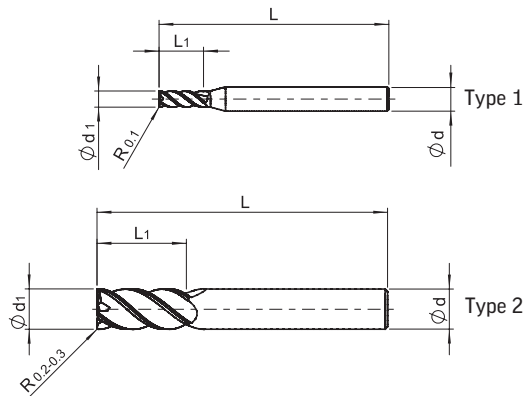

d1 (e8)	L1	d (h6)	L	Stock	Type	ART No
3	8	6	57	●	1	9244030005700-2
4	11	6	57	●	1	9244040005700-2
5	13	6	57	●	1	9244050005700-2
6	13	6	57	●	2	9244060005700-2
8	19	8	63	●	2	9244080006300-2
10	22	10	72	●	2	9244100007200-2
12	26	12	83	●	2	9244120008300-2
14	26	14	83	●	2	9244140008300-2
16	32	16	92	●	2	9244160009200-2
18	32	18	92	●	2	9244180009200-2
20	38	20	104	●	2	9244200010400-2

● In stock / В наличии

Recommended cutting conditions for end mills 9244 - Shoulder milling / Рекомендуемые режимы резания для фрез 9244 - Обработка уступов

Work material Обрабатываемый материал	Ap		Cutting speed Скорость резания Vc (m/min)	d1 - diameter in mm d1 - диаметр инструмента мм				fz - feed per tooth in mm fz - подача на зуб мм	
	Ap	Ae		Ø3 - Ø6	Ø6 - Ø8	Ø8 - Ø10	Ø10 - Ø14	Ø14 - Ø16	Ø16 - Ø20
P Carbon steel and Alloy steel < 25 HRC Углеродистые, Легированные стали, твердостью < 25 HRC	<2d1	<0.4d1	120-150	0.015-0.05	0.03-0.07	0.04-0.09	0.045-0.10	0.06-0.12	0.07-0.16
Alloy steel and Tool steel 25-45 HRC Легированные, Инструментальные стали, твердостью 25-45 HRC	<2d1	<0.3d1	60-80	0.012-0.04	0.025-0.06	0.035-0.075	0.04-0.08	0.045-0.09	0.055-0.11
M Stainless steel Нержавеющие стали	<1.5d1	<0.3d1	70-80	0.012-0.04	0.025-0.06	0.035-0.07	0.04-0.08	0.045-0.09	0.055-0.11
K Cast iron GG Серый чугун GG	<2d1	<0.4d1	130-160	0.025-0.07	0.045-0.10	0.06-0.13	0.07-0.15	0.08-0.18	0.10-0.20
Nodular cast iron GGG Высокопрочный чугун GGG	<2d1	<0.3d1	100-120	0.021-0.06	0.038-0.09	0.05-0.11	0.06-0.13	0.07-0.15	0.08-0.18
S Titanium alloy Титановые сплавы	<1.5d1	<0.2d1	30-50	0.015-0.04	0.03-0.06	0.04-0.09	0.045-0.10	0.06-0.12	0.07-0.16

Recommended cutting conditions for end mills 9244 - Slotting / Рекомендуемые режимы резания для фрез 9244 - Обработка пазов

Work material Обрабатываемый материал	Ap	Cutting speed Скорость резания Vc (m/min)	d1 - diameter in mm d1 - диаметр инструмента мм				fz - feed per tooth in mm fz - подача на зуб мм	
	Ap		Ø3 - Ø6	Ø6 - Ø8	Ø8 - Ø10	Ø10 - Ø14	Ø14 - Ø16	Ø16 - Ø20
P Carbon steel and Alloy steel < 25 HRC Углеродистые, Легированные стали, твердостью < 25 HRC	<1d1	100-130	0.008-0.03	0.017-0.04	0.02-0.05	0.025-0.06	0.03-0.07	0.04-0.08
Alloy steel and Tool steel 25-45 HRC Легированные, Инструментальные стали, твердостью 25-45 HRC	<0.7d1	50-70	0.006-0.02	0.015-0.03	0.02-0.04	0.02-0.05	0.025-0.06	0.03-0.07
M Stainless steel Нержавеющие стали	<0.7d1	50-70	0.006-0.02	0.015-0.03	0.02-0.04	0.02-0.05	0.025-0.06	0.03-0.07
K Cast iron GG Серый чугун GG	<1d1	120-140	0.01-0.04	0.02-0.05	0.025-0.07	0.03-0.07	0.035-0.08	0.035-0.11
Nodular cast iron GGG Высокопрочный чугун GGG	<1d1	90-110	0.01-0.03	0.02-0.04	0.02-0.06	0.026-0.07	0.027-0.07	0.03-0.10
S Titanium alloy Титановые сплавы	<0.3d1	20-40	0.003-0.015	0.005-0.04	0.008-0.04	0.01-0.05	0.015-0.06	0.015-0.08

UMT 9544 Z=4

End mills with different helix angles and irregular teeth for difficult to cut materials

Концевые фрезы с переменным углом наклона винтовой канавки и неравномерным расположением зубьев для труднообрабатываемых материалов

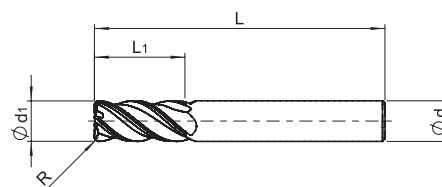
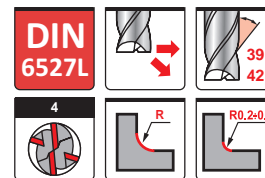

nano
TEC2

d1 (e8)	L1	d (h6)	L	R(±0.02)	Stock	ART No
6	13	6	57		●	9544060005700-2
6	13	6	57	0.5	○	9544060005705-2
6	13	6	57	1.0	○	9544060005710-2
8	19	8	63		●	9544080006300-2
8	19	8	63	0.5	○	9544080006305-2
8	19	8	63	1.0	○	9544080006310-2
10	22	10	72		●	9544100007200-2
10	22	10	72	0.5	○	9544100007205-2
10	22	10	72	1.0	○	9544100007210-2
10	22	10	72	2.0	○	9544100007220-2
12	26	12	83		●	9544120008300-2
12	26	12	83	0.5	○	9544120008305-2
12	26	12	83	1.0	○	9544120008310-2
12	26	12	83	2.0	○	9544120008320-2
16	32	16	92		●	9544160009200-2
16	32	16	92	1.0	○	9544160009210-2
16	32	16	92	2.0	○	9544160009220-2
16	32	16	92	3.0	○	9544160009230-2
20	38	20	104		●	9544200010400-2
20	38	20	104	1.0	○	9544200010410-2
20	38	20	104	2.0	○	9544200010420-2
20	38	20	104	3.0	○	9544200010430-2

- In stock / В наличии
- Produced to order only / Изготовление по запросу

Recommended cutting conditions for end mills 9544 - Shoulder milling and slotting Рекомендуемые режимы резания для фрез 9544 - Обработка уступов и пазов

Work material Обрабатываемый материал	Cutting speed Скорость резания		Cutting speed Скорость резания		d1 - diameter in mm d1 - диаметр инструмента мм						
	Ap Ae	Vc (m/min)	Ap Ae	Vc (m/min)	∅6	∅8	∅10	∅12	∅16	∅20	
P Carbon steel and Alloy steel < 25 HRC Углеродистые, Легированные стали, твердостью < 25 HRC Alloy steel and Tool steel 25-45 HRC Легированные, Инструментальные стали, твердостью 25-45 HRC	Ap	Ae	nanoTEC2	Ap	nanoTEC2						
	<2d1	<0.4d1	120-150	<1d1 max 12mm	90-120	0.03-0.04	0.05-0.06	0.06-0.07	0.07-0.08	0.08-0.09	0.09-0.10
M Stainless steel Нержавеющие стали	Ap	Ae	nanoTEC2	Ap	nanoTEC2						
	<2d1	<0.3d1	60-80	<0.7d1 max 12mm	50-70	0.025-0.035	0.045-0.055	0.05-0.06	0.06-0.07	0.07-0.08	0.08-0.09
S Titanium alloy Титановые сплавы Titanium Титан Heat resistant alloy Жаропрочные сплавы	Ap	Ae	nanoTEC2	Ap	nanoTEC2						
	<1.5d1	<0.3d1	70-80	<0.5d1	50-70	0.025-0.035	0.035-0.055	0.055-0.06	0.06-0.065	0.065-0.07	0.07-0.08
	<1.5d1	<0.2d1	40-50	<0.5d1	30-40	0.015-0.035	0.045-0.055	0.05-0.06	0.06-0.065	0.065-0.07	0.07-0.08
Titanium Титан	Ap	Ae	nanoTEC2	Ap	nanoTEC2						
	<1.5d1	<0.1d1	45-60	<0.3d1	35-45	0.012	0.015	0.019	0.025	0.034	0.042
Heat resistant alloy Жаропрочные сплавы	Ap	Ae	nanoTEC2	Ap	nanoTEC2						
	<1.5d1	0.05d1	30-40	<0.3d1	20-25	0.015	0.018	0.023	0.028	0.037	0.043

1. Cutting conditions to be adjusted according to cutting style, rigidity of machine and work clamping
 2. For high alloyed steel (> 12% Cr), INOX, titanium alloy, cutting speed must be reduced by 20-30% when used emulsion
 1. Вышеприведенные режимы указаны для жесткой технологической системы
 2. Для высоколегированных сталей (>12% Cr), нержавеющей сталей и титановых сплавов, скорость резания должна быть уменьшена на 20-30% при использовании эмульсии

UMT 9554 Z=4

End mills with different helix angles, irregular teeth, short cutting length and relieved neck for difficult to cut materials

Концевые фрезы с переменным углом наклона винтовой канавки, неравномерным расположением зубьев, короткой режущей частью и заниженной шейкой для труднообрабатываемых материалов

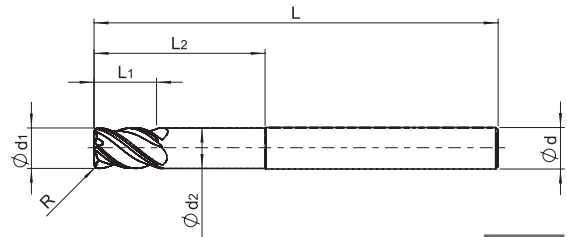
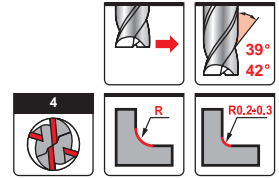

**nano
TEC2**

d1 (e8)	L1	L2	d2	d (h6)	L	R(±0.02)	Stock	ART No
6	9	26	5.8	6	75		●	9554060007500-2
6	9	26	5.8	6	75	0.5	○	9554060007505-2
6	9	26	5.8	6	75	1.0	○	9554060007510-2
8	12	34	7.8	8	75		●	9554080007500-2
8	12	34	7.8	8	75	0.5	○	9554080007505-2
8	12	34	7.8	8	75	1.0	○	9554080007510-2
10	15	42	9.7	10	100		●	9554100010000-2
10	15	42	9.7	10	100	0.5	○	9554100010005-2
10	15	42	9.7	10	100	1.0	○	9554100010010-2
10	15	42	9.7	10	100	2.0	○	9554100010020-2
12	18	50	11.7	12	100		●	9554120010000-2
12	18	50	11.7	12	100	0.5	○	9554120010005-2
12	18	50	11.7	12	100	1.0	○	9554120010010-2
12	18	50	11.7	12	100	2.0	○	9554120010020-2
16	24	65	15.5	16	115		●	9554160011500-2
16	24	65	15.5	16	115	1.0	○	9554160011510-2
16	24	65	15.5	16	115	2.0	○	9554160011520-2
16	24	65	15.5	16	115	3.0	○	9554160011530-2
20	30	82	19.5	20	140		●	9554200014000-2
20	30	82	19.5	20	140	1.0	○	9554200014010-2
20	30	82	19.5	20	140	2.0	○	9554200014020-2
20	30	82	19.5	20	140	3.0	○	9554200014030-2

● In stock / В наличии
○ Produced to order only / Изготовление по запросу

Recommended cutting conditions for end mills 9554 - Shoulder milling and slotting

Рекомендуемые режимы резания для фрез 9554 - Обработка уступов и пазов

Work material Обрабатываемый материал	Cutting speed Скорость резания		nanoTEC2	Cutting speed Скорость резания		nanoTEC2	d1 - diameter in mm d1 - диаметр инструмента мм					
	Ap Ae	Vc (m/min)		Ap	Vc (m/min)		Ø6	Ø8	Ø10	Ø12	Ø16	Ø20
P Carbon steel and Alloy steel < 25 HRC Углеродистые, Легированные стали, твердостью < 25 HRC	<1d1	<0.4d1	100-130	<1d1 max 12mm	70-100		0.03-0.04	0.05-0.06	0.06-0.07	0.07-0.08	0.08-0.09	0.09-0.10
Alloy steel and Tool steel 25-45 HRC Легированные, Инструментальные стали, твердостью 25-45 HRC	<1d1	<0.3d1	50-70	<0.7d1 max 12mm	40-60		0.025-0.035	0.045-0.055	0.05-0.06	0.06-0.07	0.07-0.08	0.08-0.09
M Stainless steel Нержавеющие стали	<1d1	<0.2d1	60-70	<0.5d1	40-60		0.025-0.035	0.035-0.055	0.055-0.06	0.06-0.065	0.065-0.07	0.07-0.08
S Titanium alloy Титановые сплавы	<1d1	<0.2d1	30-40	<0.5d1	25-35		0.015-0.035	0.045-0.055	0.05-0.06	0.06-0.065	0.065-0.07	0.07-0.08
Titanium Титан	<1d1	<0.1d1	35-50	<0.3d1	30-40		0.012	0.015	0.019	0.025	0.034	0.042
Heat resistant alloy Жаропрочные сплавы	<1d1	<0.05d1	25-35	<0.3d1	15-20		0.015	0.018	0.023	0.028	0.037	0.043

1. Cutting conditions to be adjusted according to cutting style, rigidity of machine and work clamping
2. For high alloyed steel (> 12% Cr), INOX, titanium alloy, cutting speed must be reduced by 20-30% when used emulsion

1. Вышеприведенные режимы указаны для жесткой технологической системы

2. Для высоколегированных сталей (>12% Cr), нержавеющей сталей и титановых сплавов, скорость резания должна быть уменьшена на 20-30% при использовании эмульсии

UMT 9744 Z-4 NEW

HPC Roughing end mills with different helix angles and irregular teeth for difficult to cut materials

Высокопроизводительные концевые фрезы с переменным углом наклона винтовой канавки и неравномерным расположением зубьев для труднообрабатываемых материалов

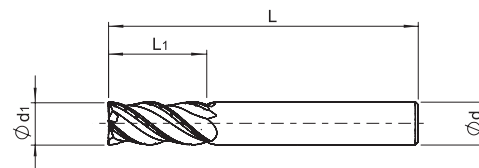
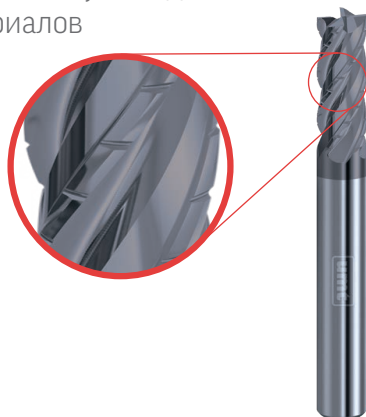

d1 (e10)	L1	d (h6)	L	Stock	ART No
6	13	6	57	●	9744060005700-2
8	19	8	63	●	9744080006300-2
10	22	10	72	●	9744100007200-2
12	26	12	83	●	9744120008300-2
16	32	16	92	●	9744160009200-2
20	38	20	104	●	9744200010400-2

nanoTEC2

● In stock / В наличии

Recommended cutting conditions for end mills 9744 - Shoulder milling and slotting
 Рекомендуемые режимы резания для фрез 9744 - Обработка уступов и пазов

Work material Обрабатываемый материал	Cutting speed Скорость резания		V _c (m/min)	Cutting speed Скорость резания		d1 - diameter in mm d1 - диаметр инструмента мм					
	Ap Ae	V _c (m/min)		Ap Ae	V _c (m/min)	Ap	Ae	fz	Ap	Ae	fz
P Carbon steel and Alloy steel < 25 HRC Углеродистые, Легированные стали, твердостью < 25 HRC	<1.8d1	<0.4d1	80-140	<1d1 max 12mm	70-110	0.034	0.044	0.052	0.054	0.064	0.075
Alloy steel and Tool steel 25-45 HRC Легированные, Инструментальные стали, твердостью 25-45 HRC	<1.8d1	<0.3d1	60-90	<0.7d1 max 12mm	50-80	0.022	0.028	0.034	0.04	0.052	0.064
M Stainless steel Нержавеющие стали	<1.8d1	<0.25d1	50-90	<0.5d1	40-70	0.02	0.025	0.028	0.032	0.038	0.05
S Titanium alloy Титановые сплавы	<1.8d1	<0.3d1	45-70	<1d1 max 12mm	30-50	0.025	0.034	0.04	0.05	0.065	0.074
Titanium Титан	<1.8d1	<0.3d1	50-75	<0.8d1 max 12mm	35-55	0.025	0.034	0.04	0.05	0.065	0.074
Heat resistant alloy Жаропрочные сплавы	<1.8d1	<0.15d1	20-40	<0.3d1	20-25	0.02	0.025	0.028	0.032	0.038	0.05

1. Cutting conditions to be adjusted according to cutting style, rigidity of machine and work clamping
 2. For high alloyed steel (> 12% Cr), INOX, titanium alloy, cutting speed must be reduced by 20-30% when used emulsion
 1. Вышеприведенные режимы указаны для жесткой технологической системы
 2. Для высоколегированных сталей (>12% Cr), нержавеющей сталей и титановых сплавов, скорость резания должна быть уменьшена на 20-30% при использовании эмульсии

UMT 9545 Z-5

HPC end mills with irregular teeth for stainless steel and difficult to cut materials

Высокопроизводительные концевые фрезы с неравномерным расположением зубьев для динамического фрезерования нержавеющей сталей и труднообрабатываемых материалов

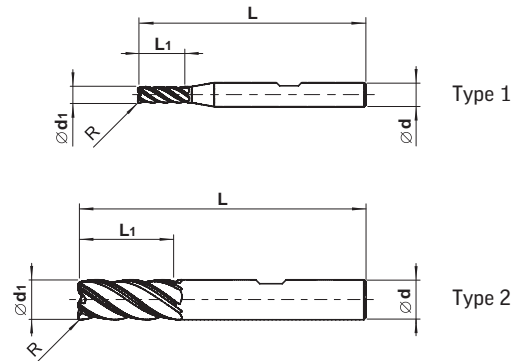
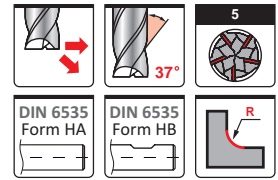

d1 (h10)	L1	d (h6)	L	R(±0.02)	Type	nano TEC2		nano TEC2	
						Stock	ART No	Stock	ART No
						Shank Style DIN 6535 HA		Shank Style DIN 6535 HB	
3	8	6	57	0.2	1	●	9545030005702-2	○	9545030005702-2-HB
4	11	6	57	0.2	1	●	9545040005702-2	○	9545040005702-2-HB
5	13	6	57	0.3	1	●	9545050005703-2	○	9545050005703-2-HB
6	13	6	57	0.3	2	●	9545060005703-2	○	9545060005703-2-HB
8	19	8	63	0.4	2	●	9545080006304-2	○	9545080006304-2-HB
10	22	10	72	0.5	2	○	9545100007205-2	●	9545100007205-2-HB
12	26	12	83	0.5	2	○	9545120008305-2	●	9545120008305-2-HB
16	32	16	92	0.5	2	○	9545160009205-2	●	9545160009205-2-HB
20	38	20	104	0.5	2	○	9545200010405-2	●	9545200010405-2-HB

● In stock / В наличии

○ Produced to order only / Изготовление по запросу

Recommended cutting conditions for end mills 9545 - Shoulder milling and slotting

Рекомендуемые режимы резания для фрез 9545 - Обработка уступов и пазов

Work material Обрабатываемый материал	Cutting speed Скорость резания		Cutting speed Скорость резания		d1 - diameter in mm d1 - диаметр инструмента мм					fz - feed per tooth in mm fz - подача на зуб мм				
	Ap Ae	Vc (m/min)	Ap Ae	Vc (m/min)	Ø3	Ø4	Ø5	Ø6	Ø8	Ø10	Ø12	Ø16	Ø20	
P Carbon steel and Alloy steel < 25 HRC Углеродистые, Легированные стали, твердостью < 25 HRC	<1.5d1	<0.4d1	150-180	<1d1 max 12mm	120-140	0.012	0.018	0.022	0.029	0.049	0.06	0.074	0.087	0.095
Alloy steel and Tool steel 25-45 HRC Легированные, Инструментальные стали, твердостью 25-45 HRC	<1.5d1	<0.4d1	80-100	<0.7d1 max 12mm	70-90	0.01	0.015	0.018	0.022	0.036	0.045	0.055	0.067	0.075
M Stainless steel Нержавеющие стали	<1.5d1	<0.4d1	90-110	<0.5d1	70-90	0.008	0.01	0.014	0.017	0.03	0.037	0.043	0.05	0.058
S Titanium alloy Титановые сплавы	<1d1	<0.3d1	60-70	<0.4d1	40-50	0.009	0.011	0.015	0.019	0.032	0.04	0.048	0.056	0.064
Titanium Титан	<1d1	<0.3d1	60-70	<0.4d1	40-50	0.007	0.009	0.013	0.016	0.025	0.034	0.04	0.046	0.052
Heat resistant alloy Жаропрочные сплавы	<1d1	<0.2d1	30-40	<0.4d1	20-25	0.006	0.008	0.01	0.012	0.02	0.024	0.028	0.034	0.04

1. The figures to be adjusted according to machining shape, rigidity of machine and work clamping

2. For high alloyed steels (>12% Cr), INOX, cutting speed must be reduced by 20-30% when used emulsion

1. Вышеприведенные режимы указаны для жесткой технологической системы

2. Для высоколегированных сталей (>12% Cr) и нержавеющей сталей, скорость резания должна быть уменьшена на 20-30% при использовании эмульсии

UMT 9226 Z-6 NEW Geometry

End mills with especially designed irregular teeth for excellent high speed semi-finishing and finishing.

Концевые фрезы с неравномерным расположением зубьев для высокоскоростной полужесткой и чистовой обработки

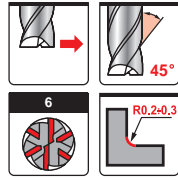

UMT 9326 Z-6 NEW Geometry

Long end mills with especially designed irregular teeth for excellent high speed semi-finishing and finishing.

Удлиненные концевые фрезы с неравномерным расположением зубьев для высокоскоростной полужесткой и чистовой обработки

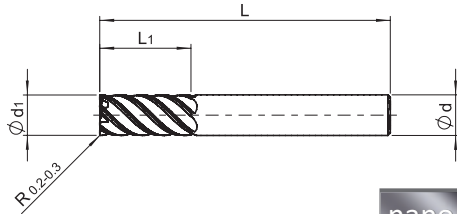
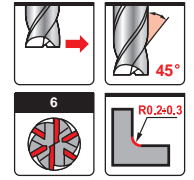

d1 (e8)	L1	d (h6)	L	Stock	ART No
6	13	6	57	●	9226060005700-2
8	19	8	63	●	9226080006300-2
10	22	10	72	●	9226100007200-2
12	26	12	83	●	9226120008300-2
16	32	16	92	●	9226160009200-2
20	38	20	104	●	9226200010400-2

● In stock / В наличии

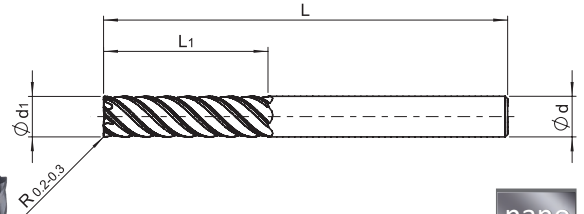

d1 (e8)	L1	d (h6)	L	Stock	ART No
6	30	6	75	●	9326060007500-2
8	30	8	75	●	9326080007500-2
10	40	10	100	●	9326100010000-2
12	45	12	100	●	9326120010000-2
16	55	16	115	●	9326160011500-2
20	65	20	120	●	9326200012000-2

● In stock / В наличии



Recommended cutting conditions for end mills 9226, 9326 - Shoulder milling
Рекомендуемые режимы резания для фрез 9226, 9326 - Обработка уступов

Work material Обрабатываемый материал	Cutting speed - 9226 Скорость резания - 9226		Cutting speed - 9326 Скорость резания - 9326		d1 - diameter in mm d1 - диаметр инструмента мм			fz - feed per tooth in mm fz - подача на зуб мм				
	Ap Ae	Vc (m/min)	Ap Ae	Vc (m/min)	Ø6	Ø8	Ø10	Ø12	Ø16	Ø20		
P Carbon steel and Alloy steel < 25 HRC Углеродистые, Легированные стали, твердостью < 25 HRC	<1.5d1	<0.1d1	150-180	<2.5d1	<0.05d1	100-120	0.03-0.04	0.04-0.05	0.05-0.055	0.055-0.065	0.065-0.075	0.075-0.085
Alloy steel and Tool steel 25-45 HRC Легированные, Инструментальные стали, твердостью 25-45 HRC	<1.5d1	<0.05d1	80-100	<2d1	<0.05d1	50-70	0.025-0.035	0.035-0.045	0.045-0.05	0.05-0.06	0.06-0.07	0.07-0.08
M Stainless steel Нержавеющие стали	<1.5d1	<0.05d1	90-110	<2d1	<0.02d1	50-60	0.025-0.035	0.035-0.045	0.045-0.05	0.05-0.06	0.06-0.07	0.07-0.08
K Cast iron GG Серый чугун GG	<1.5d1	<0.1d1	130-160	<2.5d1	<0.05d1	110-130	0.03-0.04	0.04-0.05	0.05-0.055	0.055-0.065	0.065-0.075	0.075-0.085
Nodular cast iron GGG Высокопрочный чугун GGG	<1.5d1	<0.1d1	110-140	<2.5d1	<0.05d1	100-120	0.025-0.035	0.035-0.045	0.045-0.05	0.05-0.06	0.06-0.07	0.07-0.08
S Titanium alloy Титановые сплавы	<1.5d1	<0.05d1	60-70	<2d1	<0.02d1	35-45	0.025-0.035	0.035-0.045	0.045-0.05	0.05-0.06	0.06-0.07	0.07-0.08

For high alloyed steel (>12% Cr), INOX, titanium alloy, cutting speed must be reduced by 20-30% when used emulsion
Для высоколегированных сталей (>12% Cr), нержавеющей сталей и титановых сплавов, скорость резания должна быть уменьшена на 20-30% при использовании эмульсии

UMT 9060 Z-6-10

End mills for hardened materials
 Концевые фрезы для обработки
 закаленных материалов

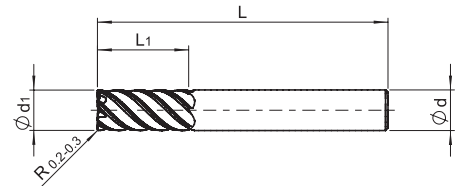

**nano
TEC1**

d1 (e8)	L1	d (h6)	L	Z	Stock	ART No
6	13	6	57	6	●	9060060005700-1
8	19	8	63	6	●	9060080006300-1
10	22	10	72	6	●	9060100007200-1
12	26	12	83	8	●	9060120008300-1
16	32	16	92	10	●	9060160009200-1

● In stock / В наличии

Recommended cutting conditions for end mills 9060 - Shoulder milling and slotting

Рекомендуемые режимы резания для фрез 9060 - Обработка уступов и пазов

Work material Обрабатываемый материал				Cutting speed Скорость резания Vc (m/min)	d1 - diameter in mm d1 - диаметр инструмента мм			
	Ap	Ae			Ap	fz - feed per tooth in mm fz - подача на зуб мм		
	Ap	Ae	Ap	nanoTEC1	∅6 - ∅8	∅8 - ∅10	∅10 - ∅12	∅12 - ∅16
H Hardened steel 45-55 HRC Закаленные стали 45-55 HRC	<1d1	<0.05d1	<0.1d1	30-50	0.02-0.025	0.025-0.03	0.03-0.04	0.03-0.05
Hardened steel 55-60 HRC Закаленные стали 55-60 HRC	<1d1	<0.05d1	<0.05d1	25-35	0.01-0.02	0.02-0.03	0.03-0.04	0.03-0.04

UMT 9654 Z=4

Ball nose end mills with short cutting length and relieved neck for hardened materials

Сферические фрезы с короткой режущей частью и заниженной шейкой для обработки закаленных материалов

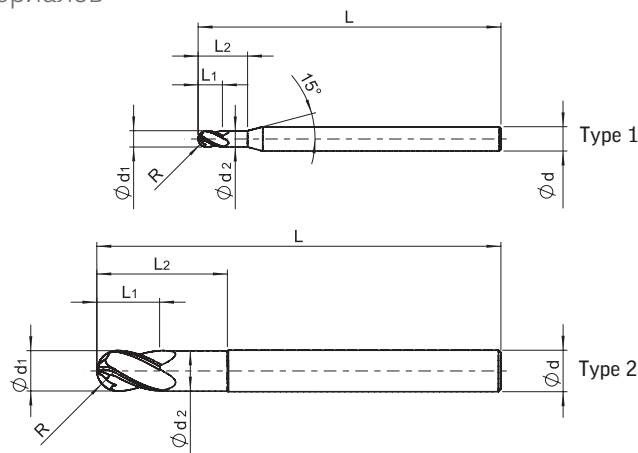
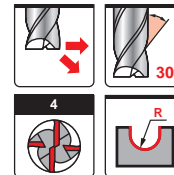

nano
TEC1

d1 (e8)	L1	L2	d2	d (h6)	L	R(d1/2)	Stock	Type	ART No
3	5	10	2.9	6	75	1.5	●	1	9654030007500-1
4	6	13	3.9	6	75	2.0	●	1	9654040007500-1
5	8	16	4.9	6	75	2.5	●	1	9654050007500-1
6	9	20	5.8	6	75	3.0	●	2	9654060007500-1
8	12	25	7.8	8	100	4.0	●	2	9654080010000-1
10	15	32	9.7	10	100	5.0	●	2	9654100010000-1
12	18	38	11.7	12	100	6.0	●	2	9654120010000-1

● In stock / В наличии

Recommended cutting conditions for end mills 9654

Рекомендуемые режимы резания для фрез 9654

Work material Обрабатываемый материал			Cutting speed Скорость резания Vc (m/min)	d1 - diameter in mm d1 - диаметр инструмента мм						
	Ap	Ae		Ø3	Ø4	Ø5	Ø6	Ø8	Ø10	Ø12
H Hardened steel 45-55 HRC Закаленные стали 45-55 HRC	<0.02d1	<0.03d1	nanoTEC1 200-250	0.04	0.048	0.05	0.054	0.057	0.057	0.059
Hardened steel 55-60 HRC Закаленные стали 55-60 HRC	<0.015d1	<0.02d1	100-150	0.038	0.045	0.046	0.052	0.056	0.056	0.058

UMT 9412 Z=2

End mills for aluminium
Концевые фрезы для обработки алюминия

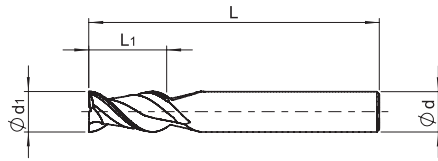
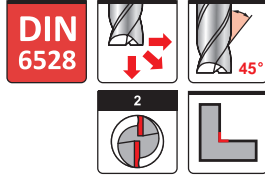

HM

d1 (e8)	L1	d (h6)	L	Stock	ART No
3	7	3	38	●	9412030003800-0
4	8	4	50	●	9412040005000-0
5	10	5	50	●	9412050005000-0
6	10	6	57	●	9412060005700-0
8	16	8	63	●	9412080006300-0
10	19	10	72	●	9412100007200-0
12	22	12	83	●	9412120008300-0
14	22	14	83	●	9412140008300-0
16	26	16	92	●	9412160009200-0
18	26	18	92	●	9412180009200-0
20	32	20	104	●	9412200010400-0

● In stock / В наличии

UMT 9413 Z=3

End mills for aluminium
Концевые фрезы для обработки алюминия

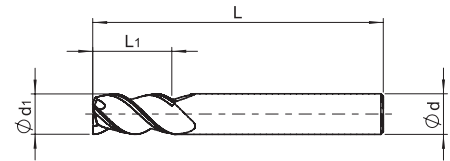

HM

d1 (e8)	L1	d (h6)	L	R(±0.02)	Stock	ART No
3	7	3	38		●	9413030003800-0
4	8	4	50		●	9413040005000-0
5	10	5	50		●	9413050005000-0
6	10	6	57		●	9413060005700-0
8	16	8	63		●	9413080006300-0
10	19	10	72		●	9413100007200-0
10	19	10	72	0.5	○	9413100007205-0
10	19	10	72	1.0	○	9413100007210-0
12	22	12	83		●	9413120008300-0
12	22	12	83	0.5	○	9413120008305-0
12	22	12	83	1.0	○	9413120008310-0
14	22	14	83		●	9413140008300-0
16	26	16	92		●	9413160009200-0
16	26	16	92	0.5	○	9413160009205-0
16	26	16	92	1.0	○	9413160009210-0
18	26	18	92		●	9413180009200-0
20	32	20	104		●	9413200010400-0

● In stock / В наличии

○ Produced to order only / Изготовление по запросу

UMT 9512 Z=2

End mills with corner radius for aluminium
Концевые фрезы с радиусом для обработки алюминия

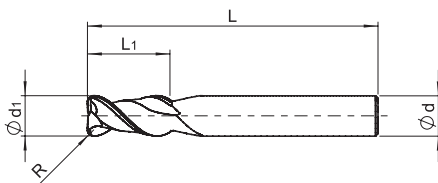
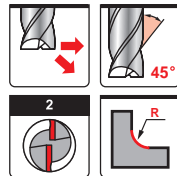

HM

d1 (e8)	L1	d (h6)	L	R(±0.02)	Stock	ART No
4	8	4	50	0.3	●	9512040005003-0
6	12	6	57	0.5	●	9512060005705-0
8	16	8	63	0.5	●	9512080006305-0
8	16	8	63	1.0	●	9512080006310-0
8	16	8	63	1.5	●	9512080006315-0
10	20	10	72	0.5	●	9512100007205-0
10	20	10	72	1.0	●	9512100007210-0
10	20	10	72	1.5	●	9512100007215-0
12	24	12	83	1.0	●	9512120008310-0
12	24	12	83	1.5	●	9512120008315-0
12	24	12	83	2.0	●	9512120008320-0

● In stock / В наличии

Recommended cutting conditions for end mills 9412, 9413, 9512 - Shoulder milling

Рекомендуемые режимы резания для фрез 9412, 9413, 9512 - Обработка уступов

Work material Обрабатываемый материал			Cutting speed Скорость резания Vc (m/min)	d1 - diameter in mm d1 - диаметр инструмента мм			fz - feed per tooth in mm fz - подача на зуб мм		
	Ap	Ae		HM	Ø3 - Ø6	Ø6 - Ø8	Ø8 - Ø10	Ø10 - Ø12	Ø12 - Ø16
N Aluminium alloy Si<8% Алюминиевые сплавы Si<8%	<1.5d1	<0.3d1	220-230	0.05-0.06	0.06-0.08	0.08-0.11	0.11-0.14	0.14-0.18	0.18-0.20
Cast aluminium Si>8% Алюминиевые сплавы Si>8%	<1.5d1	<0.3d1	180-190	0.04-0.06	0.06-0.07	0.07-0.10	0.10-0.13	0.13-0.16	0.16-0.18
Copper alloy Цветные сплавы	<1.5d1	<0.3d1	140-155	0.04-0.06	0.06-0.07	0.07-0.10	0.10-0.13	0.13-0.16	0.16-0.18

Recommended cutting conditions for end mills 9412, 9413, 9512 - Slotting

Рекомендуемые режимы резания для фрез 9412, 9413, 9512 - Обработка пазов

Work material Обрабатываемый материал			Cutting speed Скорость резания Vc (m/min)	d1 - diameter in mm d1 - диаметр инструмента мм			fz - feed per tooth in mm fz - подача на зуб мм		
	Ap	HM		Ø3 - Ø6	Ø6 - Ø8	Ø8 - Ø10	Ø10 - Ø12	Ø12 - Ø16	Ø16 - Ø20
N Aluminium alloy Si<8% Алюминиевые сплавы Si<8%	<1d1	180-190	0.02-0.04	0.04-0.06	0.06-0.08	0.08-0.11	0.11-0.13	0.13-0.16	
Cast aluminium Si>8% Алюминиевые сплавы Si>8%	<1d1	160-170	0.02-0.04	0.04-0.06	0.06-0.08	0.08-0.11	0.11-0.13	0.13-0.16	
Copper alloy Цветные сплавы	<1d1	130-140	0.02-0.04	0.04-0.06	0.06-0.08	0.08-0.11	0.11-0.13	0.13-0.16	

- Cutting conditions to be adjusted according to cutting style, rigidity of machine and work clamping
- In case of ramping, reduction of the above data by 30-60% is recommended
- Вышеприведенные режимы указаны для жесткой технологической системы
- При врезании под углом, рекомендуется снизить режимы резания на 30-60% от указанных в таблицах

High speed cutting conditions for end mills 9412, 9413, 9512 - Shoulder milling

Высокоскоростные режимы резания для фрез 9412, 9413, 9512 - Обработка уступов

Work material Обрабатываемый материал			Cutting speed Скорость резания Vc (m/min)	d1 - diameter in mm d1 - диаметр инструмента мм			fz - feed per tooth in mm fz - подача на зуб мм		
	Ap	Ae		HM	Ø3 - Ø6	Ø6 - Ø8	Ø8 - Ø10	Ø10 - Ø12	Ø12 - Ø16
N Aluminium alloy Si<8% Алюминиевые сплавы Si<8%	<0.8d1	<0.3d1	360-400	0.04-0.055	0.055-0.08	0.08-0.11	0.11-0.13	0.13-0.18	0.18-0.20
Cast aluminium Si>8% Алюминиевые сплавы Si>8%	<0.8d1	<0.3d1	330-350	0.035-0.045	0.045-0.07	0.07-0.10	0.10-0.12	0.12-0.15	0.15-0.17
Copper alloy Цветные сплавы	<0.8d1	<0.3d1	260-280	0.035-0.045	0.045-0.07	0.07-0.10	0.10-0.12	0.12-0.15	0.15-0.17

High speed cutting conditions for end mills 9412, 9413, 9512 - Slotting

Высокоскоростные режимы резания для фрез 9412, 9413, 9512 - Обработка пазов

Work material Обрабатываемый материал			Cutting speed Скорость резания Vc (m/min)	d1 - диаметр инструмента мм d1 - diameter in mm			fz - feed per tooth in mm fz - подача на зуб мм		
	Ap	HM		Ø3 - Ø6	Ø6 - Ø8	Ø8 - Ø10	Ø10 - Ø12	Ø12 - Ø16	Ø16 - Ø20
N Aluminium alloy Si<8% Алюминиевые сплавы Si<8%	<0.5d1	360-380	0.02-0.04	0.04-0.06	0.06-0.07	0.07-0.08	0.08-0.11	0.11-0.125	
Cast aluminium Si>8% Алюминиевые сплавы Si>8%	<0.5d1	290-300	0.02-0.04	0.04-0.05	0.05-0.06	0.06-0.07	0.07-0.09	0.09-0.11	
Copper alloy Цветные сплавы	<0.5d1	210-230	0.02-0.04	0.04-0.05	0.05-0.06	0.06-0.07	0.07-0.09	0.09-0.11	

- Cutting conditions to be adjusted according to cutting style, rigidity of machine and work clamping
- In case of ramping, reduction of the above data by 30-60% is recommended
- Вышеприведенные режимы указаны для жесткой технологической системы
- При врезании под углом, рекомендуется снизить режимы резания на 30-60% от указанных в таблицах

UMT 9422 Z=2

Long end mills for aluminium
Удлиненные концевые фрезы для обработки алюминия

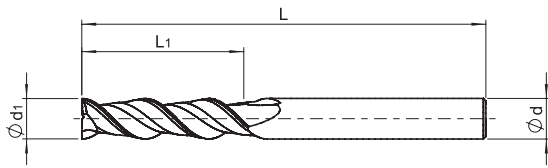
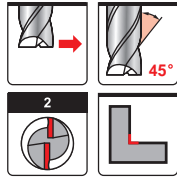

d1 (e8)	L1	d (h6)	L	Stock	ART No
3	18	3	60	●	9422030006000-0
4	24	4	60	●	9422040006000-0
5	26	5	75	●	9422050007500-0
6	30	6	75	●	9422060007500-0
8	30	8	75	●	9422080007500-0
10	40	10	100	●	9422100010000-0
12	45	12	100	●	9422120010000-0
16	45	16	100	●	9422160010000-0

● In stock / В наличии

HM

UMT 9423 Z=3

Long end mills for aluminium
Удлиненные концевые фрезы для обработки алюминия

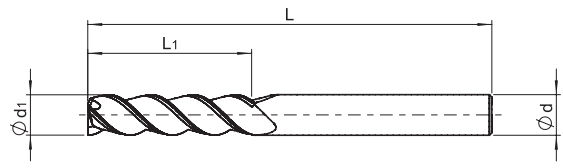
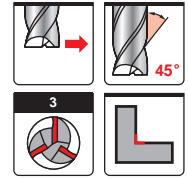

d1 (e8)	L1	d (h6)	L	Stock	ART No
3	18	3	60	●	9423030006000-0
4	24	4	60	●	9423040006000-0
5	26	5	75	●	9423050007500-0
6	30	6	75	●	9423060007500-0
8	30	8	75	●	9423080007500-0
10	40	10	100	●	9423100010000-0
12	45	12	100	●	9423120010000-0
16	45	16	100	●	9423160010000-0

● In stock / В наличии

HM

Recommended cutting conditions for end mills 9422, 9423 - Shoulder milling

Рекомендуемые режимы резания для фрез 9422, 9423 - Обработка уступов

Work material Обрабатываемый материал			Cutting speed Скорость резания Vc (m/min)	d1 - diameter in mm d1 - диаметр инструмента мм				
	Ap	Ae		fz - feed per tooth in mm fz - подача на зуб мм				
N Aluminium alloy Si<8% Алюминиевые сплавы Si<8%	<1.5d1	<0.15d1	170-180	Ø3 - Ø6	Ø6 - Ø8	Ø8 - Ø10	Ø10 - Ø12	Ø12 - Ø16
Cast aluminium Si>8% Алюминиевые сплавы Si>8%	<1.5d1	<0.15d1	140-150	0.03-0.05	0.06-0.08	0.085-0.10	0.10-0.125	0.125-0.15
Copper alloy Цветные сплавы	<1.5d1	<0.15d1	90-100	0.025-0.05	0.06-0.08	0.08-0.10	0.10-0.125	0.125-0.15
				0.025-0.05	0.06-0.08	0.08-0.09	0.09-0.12	0.12-0.15

UMT 9453 Z=3

End mills with short cutting length and relieved neck for aluminium

Концевые фрезы с короткой режущей частью и заниженной шейкой для обработки алюминия

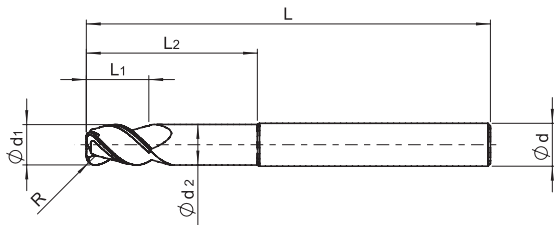
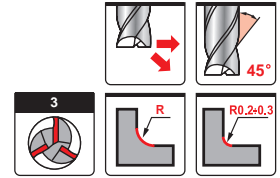

HM

d1 (ø8)	L1	L2	d2	d (h6)	L	R(±0.02)	Stock	ART No
6	10	26	5.6	6	75		●	9453060007500-0
6	10	26	5.6	6	75	0.5	○	9453060007505-0
6	10	26	5.6	6	75	1.0	○	9453060007510-0
8	12	34	7.4	8	75		●	9453080007500-0
8	12	34	7.4	8	75	0.5	○	9453080007505-0
8	12	34	7.4	8	75	1.0	○	9453080007510-0
10	15	42	9.4	10	100		●	9453100010000-0
10	15	42	9.4	10	100	0.5	○	9453100010005-0
10	15	42	9.4	10	100	1.0	○	9453100010010-0
10	15	42	9.4	10	100	2.0	○	9453100010020-0
12	18	50	11.4	12	100		●	9453120010000-0
12	18	50	11.4	12	100	0.5	○	9453120010005-0
12	18	50	11.4	12	100	1.0	○	9453120010010-0
12	18	50	11.4	12	100	2.0	○	9453120010020-0
16	24	65	15.2	16	115		●	9453160011500-0
16	24	65	15.2	16	115	1.0	○	9453160011510-0
16	24	65	15.2	16	115	2.0	○	9453160011520-0
16	24	65	15.2	16	115	3.0	○	9453160011530-0
20	30	82	18.0	20	150		●	9453200015000-0
20	30	82	18.0	20	150	1.0	○	9453200015010-0
20	30	82	18.0	20	150	2.0	○	9453200015020-0
20	30	82	18.0	20	150	3.0	○	9453200015030-0

● In stock / В наличии

○ Produced to order only / Изготовление по запросу

Recommended cutting conditions for end mills 9453 - Shoulder milling

Рекомендуемые режимы резания для фрез 9453 - Обработка уступов

Work material Обрабатываемый материал	Cutting speed Скорость резания		High Speed Cutting Высокоскоростный режим			d1 - diameter in mm d1 - диаметр инструмента мм			fz - feed per tooth in mm fz - подача на зуб мм			
	Ap Ae	Vc (m/min)	Ap Ae	Vc (m/min)	HM	Ø6	Ø8	Ø10	Ø12	Ø16	Ø20	
N Aluminium alloy Si<8% Алюминиевые сплавы Si<8%	<1.2d1	<0.1d1	165-175	<1d1	<0.1d1	270-310	0.05	0.08	0.10	0.12	0.16	0.18
Cast aluminium Si>8% Алюминиевые сплавы Si>8%	<1.2d1	<0.1d1	135-145	<1d1	<0.1d1	250-270	0.045	0.07	0.09	0.11	0.14	0.16
Copper alloy Цветные сплавы	<1.2d1	<0.1d1	105-120	<1d1	<0.1d1	195-215	0.045	0.07	0.09	0.11	0.14	0.16

Recommended cutting conditions for end mills 9453 - Slotting

Рекомендуемые режимы резания для фрез 9453 - Обработка пазов

Work material Обрабатываемый материал	Cutting speed Скорость резания		High Speed Cutting Высокоскоростный режим			d1 - diameter in mm d1 - диаметр инструмента мм			fz - feed per tooth in mm fz - подача на зуб мм		
	Ap	Vc (m/min)	Ap	Vc (m/min)	HM	Ø6	Ø8	Ø10	Ø12	Ø16	Ø20
N Aluminium alloy Si<8% Алюминиевые сплавы Si<8%	<0.8d1	135-145	<0.4d1	270-290	HM	0.04	0.06	0.07	0.08	0.11	0.125
Cast aluminium Si>8 Алюминиевые сплавы Si>8%	<0.8d1	120-130	<0.4d1	220-230	HM	0.04	0.05	0.06	0.07	0.09	0.11
Copper alloy Цветные сплавы	<0.8d1	100-110	<0.4d1	160-180	HM	0.04	0.05	0.06	0.07	0.09	0.11

1. The figures to be adjusted according to machining shape, rigidity of machine and work clamping

2. If the overhang length is more than 4d, cutting speed should be reduced

3. In case of ramping, reduction of the above data by 30-60% is recommended

1. Вышеприведенные режимы указаны для жесткой технологической системы

2. Если вылет инструмента более 4d, скорость резания должна быть снижена

3. При врезании под углом, рекомендуется снизить режимы резания на 30-60% от указанных в таблицах

UMT 9652 Z=2

Ball nose end mills with short cutting length and relieved neck for aluminium

Сферические фрезы с короткой режущей частью и заниженной шейкой для обработки алюминия

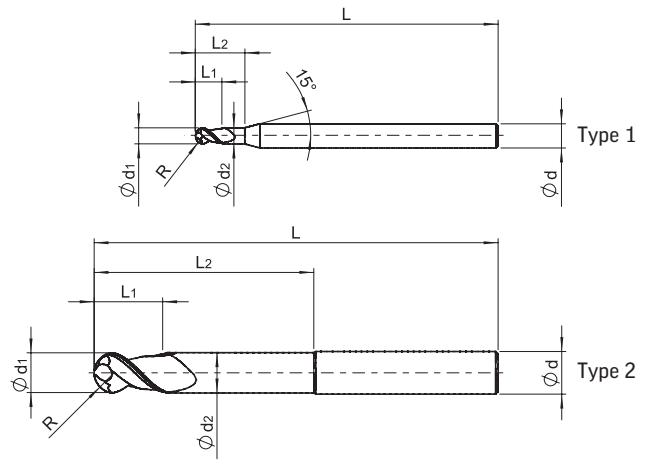
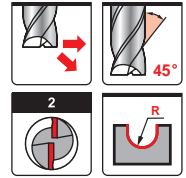

HM

d1 (e8)	L1	L2	d2	d (h6)	L	R(d1/2)	Stock	Type	ART No
3	5	9	2.7	6	75	1.5	●	1	9652030007500-0
4	6	12	3.7	6	75	2.0	●	1	9652040007500-0
5	8	15	4.7	6	75	2.5	●	1	9652050007500-0
6	10	54	5.7	6	100	3.0	●	2	9652060010000-0
8	12	54	7.4	8	100	4.0	●	2	9652080010000-0
10	15	54	9.4	10	100	5.0	●	2	9652100010000-0
12	18	80	11.4	12	150	6.0	●	2	9652120015000-0
16	24	80	15.2	16	150	8.0	●	2	9652160015000-0
20	30	80	19.0	20	150	10.0	●	2	9652200015000-0

● In stock / В наличии

Recommended cutting conditions for end mills 9652

Рекомендуемые режимы резания для фрез 9652

Work material Обрабатываемый материал			Cutting speed Скорость резания Vc (m/min)	d1 - diameter in mm d1 - диаметр инструмента мм					
	Ap	Ae		HM	∅3 - ∅6	∅6 - ∅8	∅8 - ∅10	∅10 - ∅12	∅12 - ∅16
N Aluminium alloy Si<8% Алюминиевые сплавы Si<8%	<0.2d1	<0.3d1	130-180	0.018-0.04	0.036-0.06	0.05-0.08	0.06-0.12	0.08-0.15	0.10-0.20
Cast aluminium Si>8% Алюминиевые сплавы Si>8%	<0.2d1	<0.3d1	100-130	0.018-0.04	0.036-0.06	0.05-0.08	0.06-0.12	0.08-0.15	0.10-0.20
Copper alloy Цветные сплавы	<0.1d1	<0.3d1	90-130	0.011-0.03	0.022-0.06	0.03-0.08	0.04-0.12	0.05-0.15	0.06-0.20

1. If the overhang length is more than 4d, cutting speed should be reduced
2. In case of ramping, reduction of the above data by 30-60% is recommended
1. Если вылет инструмента более 4d, скорость резания должна быть снижена
2. При врезании под углом, рекомендуется снизить режимы резания на 30-60% от указанных в таблицах

A series of horizontal dotted lines for writing.



2

SOLID CARBIDE CUTTING TOOLS
ТВЕРДОСПЛАВНЫЙ ИНСТРУМЕНТ

DRILLS
СВЕРЛА

UMT produces general range of standard solid carbide drills with 3D and 5D lengths, with and without internal cooling. The UMT drills are also being produced according to DIN standard – with reinforced shank. Thanks to the improved UMT cutting geometry, the drills are fit to machine variety of materials.

The company is able to produce special carbide drills upon request.

Компания UMT производит ассортимент стандартных твердосплавных сверл, длиной 3D и 5D, с и без внутреннего подвода СОЖ. Сверла производятся по стандарту DIN – с усиленным хвостовиком. Благодаря улучшенной режущей геометрии UMT, сверла обеспечивают обработку различных типов обрабатываемого материала.

Компания также имеет возможность поставки специальных твердосплавных сверл по запросу.

DRILLS SELECTION CHART / ТАБЛИЦА ВЫБОРА СВЕРЛ

Size range / Диапазон размеров Drilling depth / Глубина сверления Code/ Код	Shape / Форма	Cooling / Охлаждение	Coating / Покрытие	Work material / Обрабатываемый материал										Page number Номер страницы
				P	M	K	N	S						
				Carbon steel, Alloy steel Углеродистые стали, Легированные стали	High alloyed steel < 45 HRC Термообработанные стали < 45 HRC	Stainless steel Нержавеющие стали	Cast iron Серый чугун	Nodular cast iron Высокопрочный чугун	Aluminium alloy Алюминиевые сплавы	Copper alloy Медные сплавы	Titanium Титан	Titanium alloy Титановые сплавы	Heat resistant alloy Жаропрочные сплавы	
Ø3 - Ø12 - 8101		External Наружное	nanoTEC1	●	●	●	●	●	●	●	○	●	○	41
Ø3 - Ø16 3xd 8211		External Наружное	nanoTEC1	●	●	—	●	●	○	○	—	—	—	42
Ø3 - Ø16 5xd 8221		External Наружное	nanoTEC1	●	●	—	●	●	○	○	—	—	—	43
Ø3 - Ø16 5xd 8222		Internal Внутреннее	nanoTEC1	●	●	○	●	●	●	●	○	○	○	44
Ø3 - Ø16 3xd 8311		External Наружное	nanoTEC2	○	○	●	○	○	○	○	○	●	○	45
Ø3 - Ø16 5xd 8322		Internal Внутреннее	nanoTEC2	○	○	●	○	○	○	○	●	●	●	46
Ø5 - Ø16 3xd 8411		External Наружное	nanoTEC1	●	●	—	●	●	○	○	—	—	—	47

● 1st recommend / 1-ый рекомендуемый вариант ○ 2nd recommend / 2-ой рекомендуемый вариант — not recommend / не рекомендуемый вариант

**UMT 8101**

NC center drills

Центровочные сверла для станков с ЧПУ

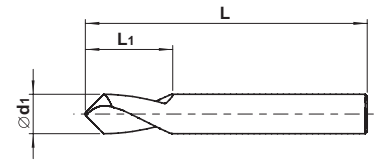
nano
TEC1

d1 (h7)	L1	L	Stock	ART No
3	9	38	●	81010300038-1
4	10	50	●	81010400050-1
5	13	50	●	81010500050-1
6	13	57	●	81010600057-1
8	20	63	●	81010800063-1
10	22	72	●	81011000072-1
12	22	83	●	81011200083-1

● In stock / В наличии

Recommended cutting conditions for drills 8101 / Рекомендуемые режимы резания для сверл 8101

Work material Обрабатываемый материал	Cutting speed Скорость резания V _c (m/min)	d1 - diameter in mm d1 - диаметр инструмента мм					
		Ø3 - Ø4	Ø4 - Ø5	Ø5 - Ø6	Ø6 - Ø8	Ø8 - Ø10	Ø10 - Ø12
	nanoTEC1						
P Carbon steel and Alloy steel < 25 HRC Углеродистые, Легированные стали, твердостью < 25 HRC	50-70	0.05-0.08	0.06-0.10	0.08-0.12	0.09-0.14	0.12-0.20	0.16-0.26
Alloy steel and Tool steel 25-45 HRC Легированные, Инструментальные стали, твердостью 25-45 HRC	30-50	0.04-0.07	0.05-0.09	0.07-0.11	0.07-0.12	0.10-0.16	0.13-0.20
M Stainless steel / Нержавеющие стали	30-40	0.03-0.07	0.04-0.09	0.06-0.11	0.06-0.12	0.09-0.12	0.12-0.18
K Cast iron GG / Серый чугун GG	60-80	0.04-0.07	0.05-0.09	0.07-0.11	0.07-0.12	0.10-0.16	0.13-0.20
Nodular cast iron GGG Высокопрочный чугун GGG	40-60	0.03-0.07	0.04-0.09	0.06-0.11	0.06-0.12	0.09-0.12	0.12-0.18
N Aluminium alloy / Алюминиевые сплавы	100-140	0.06-0.10	0.08-0.12	0.09-0.14	0.10-0.18	0.14-0.26	0.18-0.32
Copper alloy / Медные сплавы	70-100	0.06-0.09	0.08-0.11	0.09-0.13	0.10-0.16	0.12-0.20	0.15-0.26
S Titanium alloy / Титановые сплавы	20-30	0.017-0.04	0.027-0.05	0.033-0.055	0.037-0.063	0.042-0.07	0.047-0.08

UMT 8211

Twist drills with reinforced shank

Спиральные сверла с усиленным хвостовиком

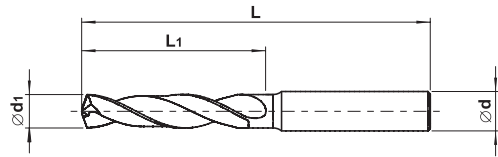
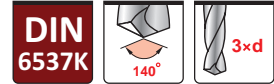

nano
TEC1

d1 (m7)	L1	d (h6)	L	Stock	ART No
3.0	20	6	62	●	82110300062-1
3.1	20	6	62	○	82110310062-1
3.2	20	6	62	○	82110320062-1
3.3	20	6	62	●	82110330062-1
3.4	20	6	62	○	82110340062-1
3.5	20	6	62	●	82110350062-1
3.6	20	6	62	○	82110360062-1
3.7	20	6	62	●	82110370062-1
3.8	24	6	66	○	82110380066-1
3.9	24	6	66	○	82110390066-1
4.0	24	6	66	●	82110400066-1
4.1	24	6	66	○	82110410066-1
4.2	24	6	66	●	82110420066-1
4.3	24	6	66	○	82110430066-1
4.4	24	6	66	○	82110440066-1
4.5	24	6	66	●	82110450066-1
4.6	24	6	66	●	82110460066-1
4.7	24	6	66	○	82110470066-1
4.8	28	6	66	○	82110480066-1
4.9	28	6	66	○	82110490066-1
5.0	28	6	66	●	82110500066-1
5.1	28	6	66	○	82110510066-1
5.2	28	6	66	●	82110520066-1
5.3	28	6	66	○	82110530066-1
5.4	28	6	66	○	82110540066-1
5.5	28	6	66	○	82110550066-1
5.6	28	6	66	●	82110560066-1
5.7	28	6	66	○	82110570066-1
5.8	28	6	66	○	82110580066-1
5.9	28	6	66	○	82110590066-1
6.0	28	6	66	●	82110600066-1
6.1	34	8	79	○	82110610079-1
6.2	34	8	79	○	82110620079-1
6.3	34	8	79	○	82110630079-1
6.4	34	8	79	○	82110640079-1
6.5	34	8	79	○	82110650079-1
6.6	34	8	79	○	82110660079-1
6.7	34	8	79	○	82110670079-1
6.8	34	8	79	●	82110680079-1
6.9	34	8	79	○	82110690079-1
7.0	34	8	79	○	82110700079-1
7.1	41	8	79	○	82110710079-1
7.2	41	8	79	○	82110720079-1
7.3	41	8	79	○	82110730079-1

nano
TEC1

d1 (m7)	L1	d (h6)	L	Stock	ART No
7.4	41	8	79	●	82110740079-1
7.5	41	8	79	○	82110750079-1
7.6	41	8	79	○	82110760079-1
7.7	41	8	79	○	82110770079-1
7.8	41	8	79	●	82110780079-1
7.9	41	8	79	○	82110790079-1
8.0	41	8	79	●	82110800079-1
8.1	47	10	89	○	82110810089-1
8.2	47	10	89	○	82110820089-1
8.3	47	10	89	○	82110830089-1
8.4	47	10	89	○	82110840089-1
8.5	47	10	89	●	82110850089-1
8.6	47	10	89	○	82110860089-1
8.7	47	10	89	○	82110870089-1
8.8	47	10	89	●	82110880089-1
8.9	47	10	89	○	82110890089-1
9.0	47	10	89	●	82110900089-1
9.1	47	10	89	○	82110910089-1
9.2	47	10	89	○	82110920089-1
9.3	47	10	89	●	82110930089-1
9.4	47	10	89	○	82110940089-1
9.5	47	10	89	●	82110950089-1
9.6	47	10	89	○	82110960089-1
9.7	47	10	89	○	82110970089-1
9.8	47	10	89	○	82110980089-1
9.9	47	10	89	○	82110990089-1
10.0	47	10	89	●	82111000089-1
10.2	55	12	102	●	82111020102-1
10.3	55	12	102	○	82111030102-1
10.5	55	12	102	●	82111050102-1
10.8	55	12	102	●	82111080102-1
11.0	55	12	102	●	82111100102-1
11.2	55	12	102	●	82111120102-1
11.5	55	12	102	○	82111150102-1
12.0	55	12	102	●	82111200102-1
12.4	60	14	107	○	82111240107-1
12.5	60	14	107	●	82111250107-1
12.7	60	14	107	○	82111270107-1
13.0	60	14	107	●	82111300107-1
13.5	60	14	107	○	82111350107-1
14.0	60	14	107	●	82111400107-1
14.5	65	16	115	●	82111450115-1
16.0	65	16	115	●	82111600115-1

● In stock / В наличии

○ Produced to order only / Изготовление по запросу

Recommended cutting conditions for drills 8211 / Рекомендуемые режимы резания для сверл 8211

Work material Обрабатываемый материал	Cutting speed Скорость резания Vc (m/min)	d1 - diameter in mm d1 - диаметр инструмента мм					
		f - feed per revolution in mm/rev. f - подача на оборот мм/об.					
	nanoTEC1	Ø3 - Ø6	Ø6 - Ø8	Ø8 - Ø10	Ø10 - Ø12	Ø12 - Ø14	Ø14 - Ø16
P Carbon steel and Alloy steel < 25 HRC Углеродистые, Легированные стали, твердостью < 25 HRC	80-110	0.08-0.15	0.14-0.20	0.15-0.20	0.18-0.25	0.20-0.28	0.22-0.30
Alloy steel and Tool steel 25-45 HRC Легированные, Инструментальные стали, твердостью 25-45 HRC	60-90	0.07-0.14	0.12-0.18	0.14-0.19	0.16-0.23	0.18-0.26	0.20-0.28
K Cast iron GG / Серый чугун GG	90-130	0.10-0.18	0.17-0.24	0.20-0.30	0.22-0.35	0.26-0.40	0.28-0.42
Nodular cast iron GGG Высокопрочный чугун GGG	60-90	0.08-0.16	0.15-0.22	0.18-0.26	0.20-0.30	0.22-0.35	0.24-0.38
N Aluminium alloy / Алюминиевые сплавы	130-160	0.10-0.16	0.16-0.22	0.20-0.26	0.22-0.28	0.24-0.30	0.28-0.36

UMT 8221

Twist drills with reinforced shank

Спиральные сверла с усиленным хвостовиком

DIN 6537L

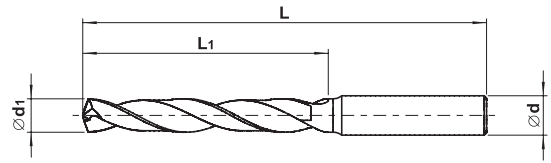

nano TEC1

d1 (m7)	L1	d (h6)	L	Stock	ART No
3.0	28	6	66	●	82210300066-1
3.1	28	6	66	○	82210310066-1
3.2	28	6	66	○	82210320066-1
3.3	28	6	66	●	82210330066-1
3.4	28	6	66	○	82210340066-1
3.5	28	6	66	●	82210350066-1
3.6	28	6	66	○	82210360066-1
3.7	28	6	66	●	82210370066-1
3.8	36	6	74	○	82210380074-1
3.9	36	6	74	○	82210390074-1
4.0	36	6	74	●	82210400074-1
4.1	36	6	74	○	82210410074-1
4.2	36	6	74	●	82210420074-1
4.3	36	6	74	○	82210430074-1
4.4	36	6	74	○	82210440074-1
4.5	36	6	74	●	82210450074-1
4.6	36	6	74	●	82210460074-1
4.7	36	6	74	○	82210470074-1
4.8	44	6	82	○	82210480082-1
4.9	44	6	82	○	82210490082-1
5.0	44	6	82	●	82210500082-1
5.1	44	6	82	○	82210510082-1
5.2	44	6	82	●	82210520082-1
5.3	44	6	82	○	82210530082-1
5.4	44	6	82	○	82210540082-1
5.5	44	6	82	○	82210550082-1
5.6	44	6	82	●	82210560082-1
5.7	44	6	82	○	82210570082-1
5.8	44	6	82	○	82210580082-1
5.9	44	6	82	○	82210590082-1
6.0	44	6	82	●	82210600082-1
6.1	53	8	91	○	82210610091-1
6.2	53	8	91	○	82210620091-1
6.3	53	8	91	○	82210630091-1
6.4	53	8	91	○	82210640091-1
6.5	53	8	91	○	82210650091-1
6.6	53	8	91	○	82210660091-1
6.7	53	8	91	○	82210670091-1
6.8	53	8	91	●	82210680091-1
6.9	53	8	91	○	82210690091-1
7.0	53	8	91	○	82210700091-1
7.1	53	8	91	○	82210710091-1
7.2	53	8	91	○	82210720091-1
7.3	53	8	91	○	82210730091-1

nano TEC1

d1 (m7)	L1	d (h6)	L	Stock	ART No
7.4	53	8	91	●	82210740091-1
7.5	53	8	91	○	82210750091-1
7.6	53	8	91	○	82210760091-1
7.7	53	8	91	○	82210770091-1
7.8	53	8	91	●	82210780091-1
7.9	53	8	91	○	82210790091-1
8.0	53	8	91	●	82210800091-1
8.1	61	10	103	○	82210810103-1
8.2	61	10	103	○	82210820103-1
8.3	61	10	103	○	82210830103-1
8.4	61	10	103	○	82210840103-1
8.5	61	10	103	●	82210850103-1
8.6	61	10	103	○	82210860103-1
8.7	61	10	103	○	82210870103-1
8.8	61	10	103	●	82210880103-1
8.9	61	10	103	○	82210890103-1
9.0	61	10	103	●	82210900103-1
9.1	61	10	103	○	82210910103-1
9.2	61	10	103	○	82210920103-1
9.3	61	10	103	●	82210930103-1
9.4	61	10	103	○	82210940103-1
9.5	61	10	103	●	82210950103-1
9.6	61	10	103	○	82210960103-1
9.7	61	10	103	○	82210970103-1
9.8	61	10	103	○	82210980103-1
9.9	61	10	103	○	82210990103-1
10.0	61	10	103	●	82211000103-1
10.2	71	12	118	●	82211020118-1
10.5	71	12	118	●	82211050118-1
10.8	71	12	118	●	82211080118-1
11.0	71	12	118	●	82211100118-1
11.2	71	12	118	●	82211120118-1
12.0	71	12	118	●	82211200118-1
12.5	77	14	124	●	82211250124-1
13.0	77	14	124	●	82211300124-1
14.0	77	14	124	●	82211400124-1
14.5	83	16	133	●	82211450133-1
16.0	83	16	133	●	82211600133-1

● In stock / В наличии

○ Produced to order only / Изготовление по запросу

Recommended cutting conditions for drills 8221 / Рекомендуемые режимы резания для сверл 8221

Work material Обрабатываемый материал	Cutting speed Скорость резания Vc (m/min)	d1 - diameter in mm d1 - диаметр инструмента мм					
		Ø3 - Ø6	Ø6 - Ø8	Ø8 - Ø10	Ø10 - Ø12	Ø12 - Ø14	Ø14 - Ø16
P Carbon steel and Alloy steel < 25 HRC Углеродистые, Легированные стали, твердостью < 25 HRC	80-110	0.08-0.15	0.14-0.20	0.15-0.20	0.18-0.25	0.20-0.28	0.22-0.30
	60-90	0.07-0.14	0.12-0.18	0.14-0.19	0.16-0.23	0.18-0.26	0.20-0.28
K Cast iron GG / Серый чугун GG Nodular cast iron GGG Высокопрочный чугун GGG	90-130	0.10-0.18	0.17-0.24	0.20-0.30	0.22-0.35	0.26-0.40	0.28-0.42
	60-90	0.08-0.16	0.15-0.22	0.18-0.26	0.20-0.30	0.22-0.35	0.24-0.38
N Aluminium alloy / Алюминиевые сплавы	130-160	0.10-0.16	0.16-0.22	0.20-0.26	0.22-0.28	0.24-0.30	0.28-0.36

UMT 8222

Twist drills with reinforced shank and internal cooling

Спиральные сверла с усиленным хвостовиком и внутренним подводом СОЖ

DIN 6537L

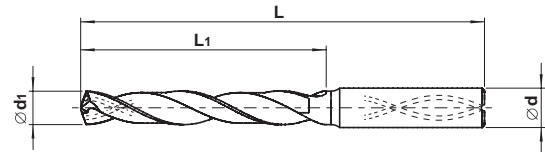

nano TEC1

d1 (m7)	L1	d (h6)	L	Stock	ART No
3.0	28	6	66	●	82220300066-1
3.1	28	6	66	○	82220310066-1
3.2	28	6	66	○	82220320066-1
3.3	28	6	66	●	82220330066-1
3.4	28	6	66	○	82220340066-1
3.5	28	6	66	●	82220350066-1
3.6	28	6	66	○	82220360066-1
3.7	28	6	66	●	82220370066-1
3.8	36	6	74	○	82220380074-1
3.9	36	6	74	○	82220390074-1
4.0	36	6	74	●	82220400074-1
4.1	36	6	74	○	82220410074-1
4.2	36	6	74	●	82220420074-1
4.3	36	6	74	○	82220430074-1
4.4	36	6	74	○	82220440074-1
4.5	36	6	74	●	82220450074-1
4.6	36	6	74	●	82220460074-1
4.7	36	6	74	○	82220470074-1
4.8	44	6	82	○	82220480082-1
4.9	44	6	82	○	82220490082-1
5.0	44	6	82	●	82220500082-1
5.1	44	6	82	○	82220510082-1
5.2	44	6	82	●	82220520082-1
5.3	44	6	82	○	82220530082-1
5.4	44	6	82	○	82220540082-1
5.5	44	6	82	○	82220550082-1
5.6	44	6	82	●	82220560082-1
5.7	44	6	82	○	82220570082-1
5.8	44	6	82	○	82220580082-1
5.9	44	6	82	○	82220590082-1
6.0	44	6	82	●	82220600082-1
6.1	53	8	91	○	82220610091-1
6.2	53	8	91	○	82220620091-1
6.3	53	8	91	○	82220630091-1
6.4	53	8	91	○	82220640091-1
6.5	53	8	91	○	82220650091-1
6.6	53	8	91	○	82220660091-1
6.7	53	8	91	○	82220670091-1
6.8	53	8	91	●	82220680091-1
6.9	53	8	91	○	82220690091-1
7.0	53	8	91	○	82220700091-1
7.1	53	8	91	○	82220710091-1
7.2	53	8	91	○	82220720091-1
7.3	53	8	91	○	82220730091-1

nano TEC1

d1 (m7)	L1	d (h6)	L	Stock	ART No
7.4	53	8	91	●	82220740091-1
7.5	53	8	91	○	82220750091-1
7.6	53	8	91	○	82220760091-1
7.7	53	8	91	○	82220770091-1
7.8	53	8	91	●	82220780091-1
7.9	53	8	91	○	82220790091-1
8.0	53	8	91	●	82220800091-1
8.1	61	10	103	○	82220810103-1
8.2	61	10	103	○	82220820103-1
8.3	61	10	103	○	82220830103-1
8.4	61	10	103	○	82220840103-1
8.5	61	10	103	●	82220850103-1
8.6	61	10	103	○	82220860103-1
8.7	61	10	103	○	82220870103-1
8.8	61	10	103	●	82220880103-1
8.9	61	10	103	○	82220890103-1
9.0	61	10	103	●	82220900103-1
9.1	61	10	103	○	82220910103-1
9.2	61	10	103	○	82220920103-1
9.3	61	10	103	●	82220930103-1
9.4	61	10	103	○	82220940103-1
9.5	61	10	103	●	82220950103-1
9.6	61	10	103	○	82220960103-1
9.7	61	10	103	○	82220970103-1
9.8	61	10	103	○	82220980103-1
9.9	61	10	103	○	82220990103-1
10.0	61	10	103	●	82221000103-1
10.2	71	12	118	●	82221020118-1
10.5	71	12	118	●	82221050118-1
10.8	71	12	118	●	82221080118-1
11.0	71	12	118	●	82221100118-1
11.2	71	12	118	●	82221120118-1
11.7	71	12	118	○	82221170118-1
12.0	71	12	118	●	82221200118-1
12.5	77	14	124	●	82221250124-1
13.0	77	14	124	●	82221300124-1
14.0	77	14	124	●	82221400124-1
14.5	83	16	133	●	82221450133-1
15.0	83	16	133	○	82221500133-1
16.0	83	16	133	●	82221600133-1

- In stock / В наличии
- Produced to order only / Изготовление по запросу

Recommended cutting conditions for drills 8222 / Рекомендуемые режимы резания для сверл 8222

Work material Обрабатываемый материал	Cutting speed Скорость резания Vc (m/min)	d1 - diameter in mm d1 - диаметр инструмента мм					
		f - feed per revolution in mm/rev. f - подача на оборот мм/об.					
	nanoTEC1	Ø3 - Ø6	Ø6 - Ø8	Ø8 - Ø10	Ø10 - Ø12	Ø12 - Ø14	Ø14 - Ø16
P Carbon steel and Alloy steel < 25 HRC Углеродистые, Легированные стали, твердостью < 25 HRC	90-130	0.08-0.15	0.14-0.20	0.15-0.20	0.18-0.25	0.20-0.28	0.22-0.30
Alloy steel and Tool steel 25-45 HRC Легированные, Инструментальные стали, твердостью 25-45 HRC	70-100	0.07-0.14	0.12-0.18	0.14-0.19	0.16-0.23	0.18-0.26	0.20-0.28
K Cast iron GG / Серый чугун GG	100-140	0.10-0.18	0.17-0.24	0.20-0.30	0.22-0.35	0.26-0.40	0.28-0.42
Nodular cast iron GGG Высокопрочный чугун GGG	80-110	0.08-0.16	0.15-0.22	0.18-0.26	0.20-0.30	0.22-0.35	0.24-0.38
N Aluminium alloy / Алюминиевые сплавы	150-180	0.10-0.16	0.16-0.22	0.20-0.26	0.22-0.28	0.24-0.30	0.28-0.36

UMT 8311

Twist drills with reinforced shank for difficult to cut materials

Спиральные сверла с усиленным хвостовиком для обработки труднообрабатываемых материалов

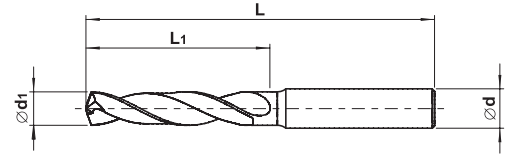

nano TEC2

d1 (m7)	L1	d (h6)	L	Stock	ART No
3.0	20	6	62	o	83110300062-2
3.1	20	6	62	o	83110310062-2
3.2	20	6	62	o	83110320062-2
3.3	20	6	62	o	83110330062-2
3.4	20	6	62	o	83110340062-2
3.5	20	6	62	o	83110350062-2
3.6	20	6	62	o	83110360062-2
3.7	20	6	62	o	83110370062-2
3.8	24	6	66	o	83110380066-2
3.9	24	6	66	o	83110390066-2
4.0	24	6	66	o	83110400066-2
4.1	24	6	66	o	83110410066-2
4.2	24	6	66	o	83110420066-2
4.3	24	6	66	o	83110430066-2
4.4	24	6	66	o	83110440066-2
4.5	24	6	66	o	83110450066-2
4.6	24	6	66	o	83110460066-2
4.7	24	6	66	o	83110470066-2
4.8	28	6	66	o	83110480066-2
4.9	28	6	66	o	83110490066-2
5.0	28	6	66	o	83110500066-2
5.1	28	6	66	o	83110510066-2
5.2	28	6	66	o	83110520066-2
5.3	28	6	66	o	83110530066-2
5.4	28	6	66	o	83110540066-2
5.5	28	6	66	o	83110550066-2
5.6	28	6	66	o	83110560066-2
5.7	28	6	66	o	83110570066-2
5.8	28	6	66	o	83110580066-2
5.9	28	6	66	o	83110590066-2
6.0	28	6	66	o	83110600066-2
6.1	34	8	79	o	83110610079-2
6.2	34	8	79	o	83110620079-2
6.3	34	8	79	o	83110630079-2
6.4	34	8	79	o	83110640079-2
6.5	34	8	79	o	83110650079-2
6.6	34	8	79	o	83110660079-2
6.7	34	8	79	o	83110670079-2
6.8	34	8	79	o	83110680079-2
6.9	34	8	79	o	83110690079-2
7.0	34	8	79	o	83110700079-2
7.1	41	8	79	o	83110710079-2
7.2	41	8	79	o	83110720079-2
7.3	41	8	79	o	83110730079-2

nano TEC2

d1 (m7)	L1	d (h6)	L	Stock	ART No
7.4	41	8	79	o	83110740079-2
7.5	41	8	79	o	83110750079-2
7.6	41	8	79	o	83110760079-2
7.7	41	8	79	o	83110770079-2
7.8	41	8	79	o	83110780079-2
7.9	41	8	79	o	83110790079-2
8.0	41	8	79	o	83110800079-2
8.1	47	10	89	o	83110810089-2
8.2	47	10	89	o	83110820089-2
8.3	47	10	89	o	83110830089-2
8.4	47	10	89	o	83110840089-2
8.5	47	10	89	o	83110850089-2
8.6	47	10	89	o	83110860089-2
8.7	47	10	89	o	83110870089-2
8.8	47	10	89	o	83110880089-2
8.9	47	10	89	o	83110890089-2
9.0	47	10	89	o	83110900089-2
9.1	47	10	89	o	83110910089-2
9.2	47	10	89	o	83110920089-2
9.3	47	10	89	o	83110930089-2
9.4	47	10	89	o	83110940089-2
9.5	47	10	89	o	83110950089-2
9.6	47	10	89	o	83110960089-2
9.7	47	10	89	o	83110970089-2
9.8	47	10	89	o	83110980089-2
9.9	47	10	89	o	83110990089-2
10.0	47	10	89	o	83111000089-2
10.2	55	12	102	o	83111020102-2
10.3	55	12	102	o	83111030102-2
10.5	55	12	102	o	83111050102-2
10.8	55	12	102	o	83111080102-2
11.0	55	12	102	o	83111100102-2
11.2	55	12	102	o	83111120102-2
11.5	55	12	102	o	83111150102-2
12.0	55	12	102	o	83111200102-2
12.4	60	14	107	o	83111240107-2
12.5	60	14	107	o	83111250107-2
12.7	60	14	107	o	83111270107-2
13.0	60	14	107	o	83111300107-2
13.5	60	14	107	o	83111350107-2
14.0	60	14	107	o	83111400107-2
14.5	65	16	115	o	83111450115-2
16.0	65	16	115	o	83111600115-2

o Produced to order only / Изготовление по запросу

Recommended cutting conditions for drills 8311 / Рекомендуемые режимы резания для сверл 8311

Work material Обрабатываемый материал	Cutting speed Скорость резания Vc (m/min)	d1 - diameter in mm d1 - диаметр инструмента мм					
		f - feed per revolution in mm/rev. f - подача на оборот мм/об.		Ø3 - Ø6	Ø6 - Ø8	Ø8 - Ø10	Ø10 - Ø12
nanoTEC2							
M Stainless steel Low alloy austenitic Нержавеющие стали	30-50	0.04-0.10	0.08-0.12	0.09-0.14	0.12-0.20	0.16-0.22	0.18-0.24
Stainless steel High alloy austenitic Нержавеющие стали	25-45	0.04-0.10	0.08-0.12	0.09-0.14	0.12-0.20	0.16-0.22	0.18-0.24
S Titanium alloy / Титановые сплавы	25-40	0.033-0.07	0.07-0.10	0.084-0.12	0.094-0.13	0.10-0.14	0.12-0.14
Titanium / Титан	25-40	0.033-0.07	0.07-0.10	0.084-0.12	0.094-0.13	0.10-0.14	0.12-0.14
Heat resistant alloy Жаропрочные сплавы	15-25	0.025-0.055	0.055-0.084	0.063-0.094	0.07-0.10	0.08-0.12	0.09-0.13

UMT 8322

Twist drills with reinforced shank and internal cooling for difficult to cut materials

Спиральные сверла с усиленным хвостовиком и внутренним подводом СОЖ для обработки труднообрабатываемых материалов

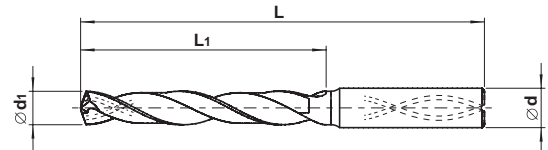

nano
TEC2

d1 (m7)	L1	d (h6)	L	Stock	ART No
3.0	28	6	66	●	83220300066-2
3.1	28	6	66	○	83220310066-2
3.2	28	6	66	○	83220320066-2
3.3	28	6	66	●	83220330066-2
3.4	28	6	66	○	83220340066-2
3.5	28	6	66	●	83220350066-2
3.6	28	6	66	○	83220360066-2
3.7	28	6	66	●	83220370066-2
3.8	36	6	74	○	83220380074-2
3.9	36	6	74	○	83220390074-2
4.0	36	6	74	●	83220400074-2
4.1	36	6	74	○	83220410074-2
4.2	36	6	74	●	83220420074-2
4.3	36	6	74	○	83220430074-2
4.4	36	6	74	○	83220440074-2
4.5	36	6	74	●	83220450074-2
4.6	36	6	74	●	83220460074-2
4.7	36	6	74	○	83220470074-2
4.8	44	6	82	○	83220480082-2
4.9	44	6	82	○	83220490082-2
5.0	44	6	82	●	83220500082-2
5.1	44	6	82	○	83220510082-2
5.2	44	6	82	●	83220520082-2
5.3	44	6	82	○	83220530082-2
5.4	44	6	82	○	83220540082-2
5.5	44	6	82	○	83220550082-2
5.6	44	6	82	●	83220560082-2
5.7	44	6	82	○	83220570082-2
5.8	44	6	82	○	83220580082-2
5.9	44	6	82	○	83220590082-2
6.0	44	6	82	●	83220600082-2
6.1	53	8	91	○	83220610091-2
6.2	53	8	91	○	83220620091-2
6.3	53	8	91	○	83220630091-2
6.4	53	8	91	○	83220640091-2
6.5	53	8	91	○	83220650091-2
6.6	53	8	91	○	83220660091-2
6.7	53	8	91	○	83220670091-2
6.8	53	8	91	●	83220680091-2
6.9	53	8	91	○	83220690091-2
7.0	53	8	91	○	83220700091-2
7.1	53	8	91	○	83220710091-2
7.2	53	8	91	○	83220720091-2
7.3	53	8	91	○	83220730091-2

nano
TEC2

d1 (m7)	L1	d (h6)	L	Stock	ART No
7.4	53	8	91	●	83220740091-2
7.5	53	8	91	○	83220750091-2
7.6	53	8	91	○	83220760091-2
7.7	53	8	91	○	83220770091-2
7.8	53	8	91	●	83220780091-2
7.9	53	8	91	○	83220790091-2
8.0	53	8	91	●	83220800091-2
8.1	61	10	103	○	83220810103-2
8.2	61	10	103	○	83220820103-2
8.3	61	10	103	○	83220830103-2
8.4	61	10	103	○	83220840103-2
8.5	61	10	103	●	83220850103-2
8.6	61	10	103	○	83220860103-2
8.7	61	10	103	○	83220870103-2
8.8	61	10	103	●	83220880103-2
8.9	61	10	103	○	83220890103-2
9.0	61	10	103	●	83220900103-2
9.1	61	10	103	○	83220910103-2
9.2	61	10	103	○	83220920103-2
9.3	61	10	103	●	83220930103-2
9.4	61	10	103	○	83220940103-2
9.5	61	10	103	●	83220950103-2
9.6	61	10	103	○	83220960103-2
9.7	61	10	103	○	83220970103-2
9.8	61	10	103	○	83220980103-2
9.9	61	10	103	○	83220990103-2
10.0	61	10	103	●	83221000103-2
10.2	71	12	118	●	83221020118-2
10.5	71	12	118	●	83221050118-2
10.8	71	12	118	●	83221080118-2
11.0	71	12	118	●	83221100118-2
11.2	71	12	118	●	83221120118-2
11.7	71	12	118	○	83221170118-2
12.0	71	12	118	●	83221200118-2
12.5	77	14	124	○	83221250124-2
13.0	77	14	124	○	83221300124-2
14.0	77	14	124	○	83221400124-2
14.5	83	16	133	○	83221450133-2
15.0	83	16	133	○	83221500133-2
16.0	83	16	133	○	83221600133-2

- In stock / В наличии
- Produced to order only / Изготовление по запросу

Recommended cutting conditions for drills 8322 / Рекомендуемые режимы резания для сверл 8322

Work material Обрабатываемый материал	Cutting speed Скорость резания Vc (m/min)	d1 - diameter in mm d1 - диаметр инструмента мм			f - feed per revolution in mm/rev. f - подача на оборот мм/об.		
		Ø3 - Ø6	Ø6 - Ø8	Ø8 - Ø10	Ø10 - Ø12	Ø12 - Ø14	Ø14 - Ø16
nanoTEC2							
M Stainless steel Low alloy austenitic Нержавеющие стали	40-60	0.04-0.10	0.08-0.12	0.09-0.14	0.12-0.20	0.16-0.22	0.18-0.24
Stainless steel High alloy austenitic Нержавеющие стали	35-55	0.04-0.10	0.08-0.12	0.09-0.14	0.12-0.20	0.16-0.22	0.18-0.24
S Titanium alloy / Титановые сплавы	35-45	0.033-0.07	0.07-0.10	0.084-0.12	0.094-0.13	0.10-0.14	0.12-0.14
Titanium / Титан	35-45	0.033-0.07	0.07-0.10	0.084-0.12	0.094-0.13	0.10-0.14	0.12-0.14
Heat resistant alloy Жаропрочные сплавы	15-30	0.025-0.055	0.055-0.084	0.063-0.094	0.07-0.10	0.08-0.12	0.09-0.13



UMT 8411 Z-3

Twist drills with reinforced shank

Спиральные сверла с усиленным хвостовиком

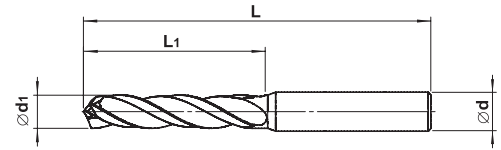

							nano TEC1
d1 (m7)	L1	d (h6)	L	Stock	ART No		
5.0	28	6	66	o	84110500066-1		
5.1	28	6	66	o	84110510066-1		
5.2	28	6	66	o	84110520066-1		
5.3	28	6	66	o	84110530066-1		
5.4	28	6	66	o	84110540066-1		
5.5	28	6	66	o	84110550066-1		
5.6	28	6	66	o	84110560066-1		
5.7	28	6	66	o	84110570066-1		
5.8	28	6	66	o	84110580066-1		
5.9	28	6	66	o	84110590066-1		
6.0	28	6	66	o	84110600066-1		
6.1	34	8	79	o	84110610079-1		
6.2	34	8	79	o	84110620079-1		
6.3	34	8	79	o	84110630079-1		
6.4	34	8	79	o	84110640079-1		
6.5	34	8	79	o	84110650079-1		
6.6	34	8	79	o	84110660079-1		
6.7	34	8	79	o	84110670079-1		
6.8	34	8	79	o	84110680079-1		
6.9	34	8	79	o	84110690079-1		
7.0	34	8	79	o	84110700079-1		
7.1	41	8	79	o	84110710079-1		
7.2	41	8	79	o	84110720079-1		
7.3	41	8	79	o	84110730079-1		
7.4	41	8	79	o	84110740079-1		
7.5	41	8	79	o	84110750079-1		
7.6	41	8	79	o	84110760079-1		
7.7	41	8	79	o	84110770079-1		
7.8	41	8	79	o	84110780079-1		
7.9	41	8	79	o	84110790079-1		
8.0	41	8	79	o	84110800079-1		
8.1	47	10	89	o	84110810089-1		
8.2	47	10	89	o	84110820089-1		
8.3	47	10	89	o	84110830089-1		
8.4	47	10	89	o	84110840089-1		

							nano TEC1
d1 (m7)	L1	d (h6)	L	Stock	ART No		
8.5	47	10	89	o	84110850089-1		
8.6	47	10	89	o	84110860089-1		
8.7	47	10	89	o	84110870089-1		
8.8	47	10	89	o	84110880089-1		
8.9	47	10	89	o	84110890089-1		
9.0	47	10	89	o	84110900089-1		
9.1	47	10	89	o	84110910089-1		
9.2	47	10	89	o	84110920089-1		
9.3	47	10	89	o	84110930089-1		
9.4	47	10	89	o	84110940089-1		
9.5	47	10	89	o	84110950089-1		
9.6	47	10	89	o	84110960089-1		
9.7	47	10	89	o	84110970089-1		
9.8	47	10	89	o	84110980089-1		
9.9	47	10	89	o	84110990089-1		
10.0	47	10	89	o	84111000089-1		
10.2	55	12	102	o	84111020102-1		
10.3	55	12	102	o	84111030102-1		
10.5	55	12	102	o	84111050102-1		
10.8	55	12	102	o	84111080102-1		
11.0	55	12	102	o	84111100102-1		
11.2	55	12	102	o	84111120102-1		
11.5	55	12	102	o	84111150102-1		
12.0	55	12	102	o	84111200102-1		
12.4	60	14	107	o	84111240107-1		
12.5	60	14	107	o	84111250107-1		
12.7	60	14	107	o	84111270107-1		
13.0	60	14	107	o	84111300107-1		
13.5	60	14	107	o	84111350107-1		
14.0	60	14	107	o	84111400107-1		
14.5	65	16	115	o	84111450115-1		
16.0	65	16	115	o	84111600115-1		

● In stock / В наличии

○ Produced to order only / Изготовление по запросу

Recommended cutting conditions for drills 8411 / Рекомендуемые режимы резания для сверл 8411

Work material Обрабатываемый материал	Cutting speed Скорость резания Vc (m/min)	d1 - diameter in mm d1 - диаметр инструмента мм					
		ø5 - ø6	ø6 - ø8	ø8 - ø10	ø10 - ø12	ø12 - ø14	ø14 - ø16
	nanoTEC1						
P Carbon steel and Alloy steel < 25 HRC Углеродистые, Легированные стали, твердостью < 25 HRC	80-100	0.30-0.35	0.35-0.42	0.42-0.50	0.50-0.55	0.55-0.60	0.60-0.66
Alloy steel and Tool steel 25-45 HRC Легированные, Инструментальные стали, твердостью 25-45 HRC	55-70	0.24-0.29	0.29-0.34	0.34-0.40	0.40-0.44	0.44-0.48	0.48-0.52
K Cast iron GG / Серый чугун GG	80-100	0.30-0.38	0.35-0.46	0.42-0.55	0.50-0.60	0.55-0.66	0.60-0.70
Nodular cast iron GGG Высокопрочный чугун GGG	60-80	0.26-0.32	0.30-0.38	0.36-0.46	0.44-0.52	0.48-0.56	0.50-0.58
N Aluminium alloy / Алюминиевые сплавы	120-160	0.32-0.38	0.37-0.46	0.44-0.55	0.52-0.60	0.58-0.66	0.64-0.70





3

ON REQUEST
ПО ЗАПРОСУ

SPECIAL TOOLS
СПЕЦИАЛЬНЫЕ
ИНСТРУМЕНТЫ

SPECIAL END MILLS / СПЕЦИАЛЬНЫЕ ФРЕЗЫ

Date / Дата:

Customer / Клиент:

Attn / К вниманию инженера:

Phone / Тел.:

e-mail:

Select type of tool / Укажите тип инструмента

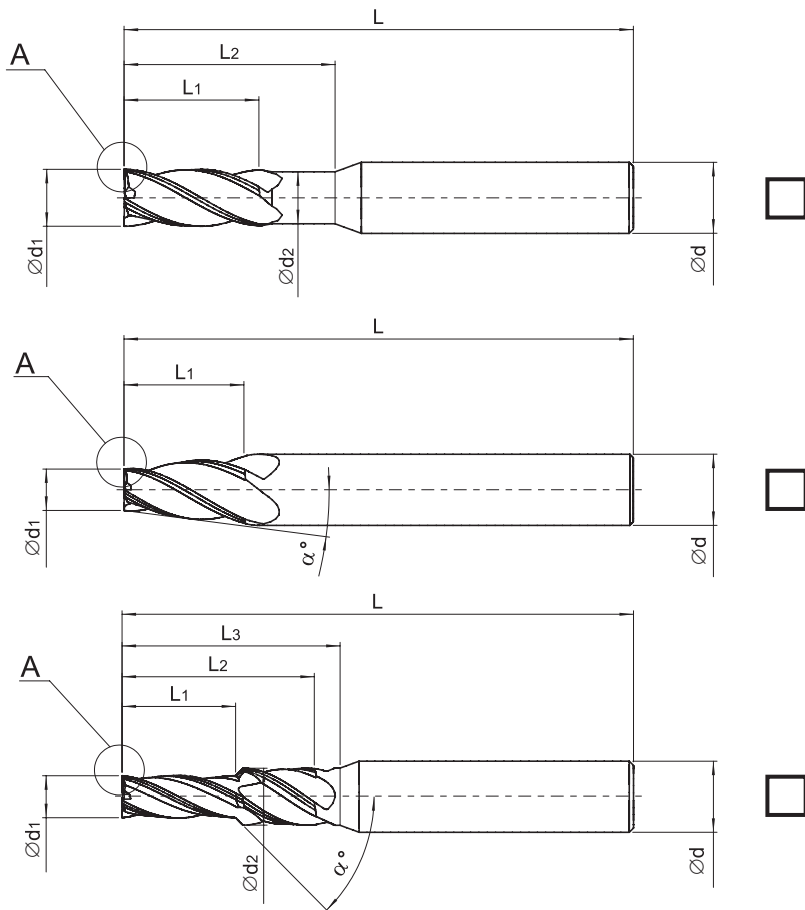

Ød	mm MM
Ød1	mm MM
Ød2	mm MM
L	mm MM
L1	mm MM
L2	mm MM
L3	mm MM
α	°
Ch	mm MM
αCh	°
Rcr	mm MM
R	mm MM
r	mm MM

Select shape A / Укажите вид A

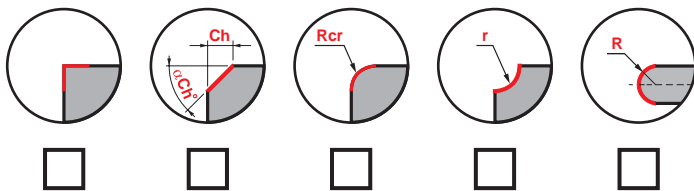

Material to be machined / Обрабатываемый материал:

Internal cooling / Внутреннее охлаждение: Yes / Да No / Нет

Number of flutes / Количество зубьев:

Helix angle / Угол наклона винтовой канавки:

Coating / Покрытие: Yes / Да No / Нет

Quantity, pcs. / Количество, шт.:

Notes / Примечания:

STEP DRILLS / СТУПЕНЧАТЫЕ СВЕРЛА

Date / Дата:
 Customer / Клиент:
 Attn / К вниманию инженера:
 Phone / Тел.:
 e-mail:

Select type of tool / Укажите тип инструмента

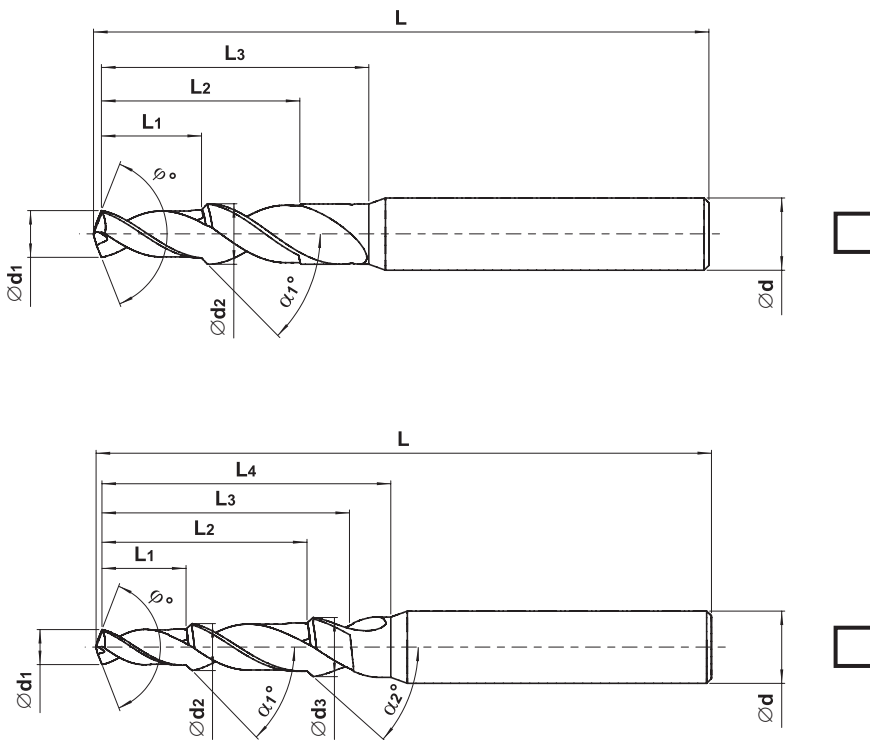

Ød	mm MM
Ød1	mm MM
Ød2	mm MM
Ød3	mm MM
L	mm MM
L1	mm MM
L2	mm MM
L3	mm MM
L4	mm MM
φ	°
α1	°
α2	°

Material to be machined / Обрабатываемый материал:
 Internal cooling / Внутреннее охлаждение: Yes / Да No / Нет
 Number of flutes / Количество зубьев:
 Helix angle / Угол наклона винтовой канавки:
 Coating / Покрытие: Yes / Да No / Нет
 Quantity, pcs. / Количество, шт.:
 Notes / Примечания:

T-SLOT END MILLS / Т-ОБРАЗНЫЕ ФРЕЗЫ

Date / Дата:

Customer / Клиент:

Attn / К вниманию инженера:

Phone / Тел.:

e-mail:

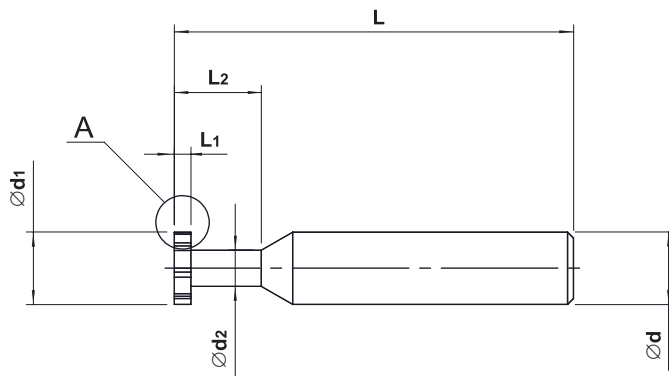

Ød	mm MM
Ød1	mm MM
Ød2	mm MM
L	mm MM
L1	mm MM
L2	mm MM
R	mm MM
Ch1	mm MM
Ch2	mm MM
αCh1	°
αCh2	°
Rcr1	mm MM
Rcr2	mm MM
R	mm MM

Укажите вид A / Select shape A

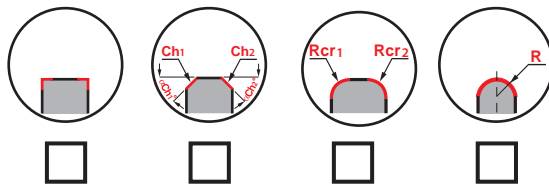

Material to be machined / Обрабатываемый материал:

Internal cooling / Внутреннее охлаждение: Yes / Да No / Нет

Number of flutes / Количество зубьев:

Helix angle / Угол наклона винтовой канавки:

Coating / Покрытие: Yes / Да No / Нет

Quantity, pcs. / Количество, шт.:

Notes / Примечания:

REAMERS / РАЗВЕРТКИ

Date / Дата:

Customer / Клиент:

Attn / К вниманию инженера:

Phone / Тел.:

e-mail:

Select type of tool / Укажите тип инструмента

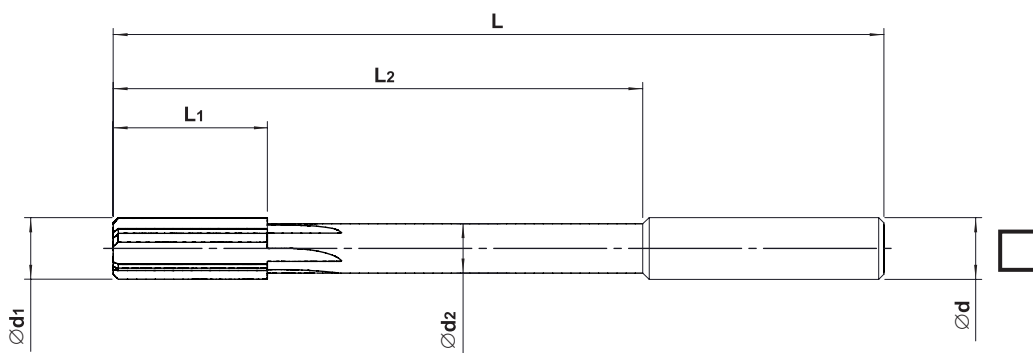

Ød	mm MM
Ød1	mm MM
Ød2	mm MM
L	mm MM
L1	mm MM
L2	mm MM

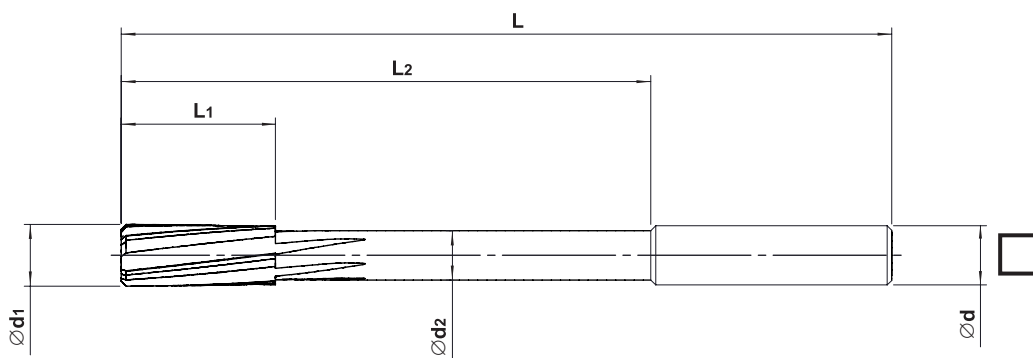

Material to be machined / Обрабатываемый материал:

Internal cooling / Внутреннее охлаждение: Yes / Да No / Нет

Number of flutes / Количество зубьев:

Helix angle / Угол наклона винтовой канавки:

Coating / Покрытие: Yes / Да No / Нет

Quantity, pcs. / Количество, шт.:

Notes / Примечания:

TOOLS WITH CARBIDE INSERTS
ИНСТРУМЕНТ СО СМЕННЫМИ
ТВЕРДОСПЛАВНЫМИ
ПЛАСТИНАМИ



TOOLS WITH CARBIDE INSERTS
ИНСТРУМЕНТ СО СМЕННЫМИ ТВЕРДОСПЛАВНЫМИ ПЛАСТИНАМИ

TURNING CARBIDE INSERTS
ТОКАРНЫЕ ТВЕРДОСПЛАВНЫЕ
ПЛАСТИНЫ

TABLE OF CONTENTS / СОДЕРЖАНИЕ

SOLID CARBIDE TOOLS		3
ТВЕРДОСПЛАВНЫЙ ИНСТРУМЕНТ		
1	Carbide mills Твердосплавные фрезы	5
2	Carbide drills Твердосплавные сверла	39
3	Special tools Специальные инструменты	49
 TOOLS WITH CARBIDE INSERTS		 54
ИНСТРУМЕНТ СО СМЕННЫМИ ТВЕРДОСПЛАВНЫМИ ПЛАСТИНАМИ		
4	Turning carbide inserts Токарные твердосплавные пластины	55
<input type="checkbox"/>	Alloy description Описание сплавов	57
<input type="checkbox"/>	Alloy application Область применения сплавов	60
<input type="checkbox"/>	Description of chipbreakers and depth of cut and feed Описание стружколомов, глубина резания и подача	61
<input type="checkbox"/>	Inserts designation Обозначение пластин	66
<input type="checkbox"/>	Negative angle Пластины с отрицательным задним углом	68
<input type="checkbox"/>	Positive angle Пластины с положительным задним углом	80
<input type="checkbox"/>	Cutting speed Режимы резания	88
5	Toolholders for external turning Токарные державки для наружной обработки	91
6	Toolholders for internal turning Токарные державки для внутренней обработки	123
7	Grooving and parting off Канавка и отрезка	143
8	Threading inserts Резьбонарезные пластины	175
9	Milling with carbide inserts Фрезы со сменными твердосплавными пластинами	217
10	Drills with carbide inserts Сверла со сменными пластинами	271

TC10

HT-P15 | HT-M10 | HT-K10

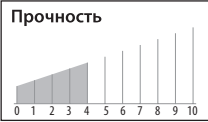
**Specification:**

Composition: Cermet Co/Ni 12.2 %; WC 15.0 %; TaNbC 10.0 %; TiCN balance | Hardness: HV30 1620

Recommended application: The uncoated cermet grade for the finishing of hardened steel.

Состав: Кермет Co/Ni 12.2%; WC 15.0%; TaNbC 10.0%; TiCN остальное;
Твердость: HV 1620;

Рекомендации к применению: Высокая скорость резания. Идеально для финишной обработки стали и нержавеющей стали

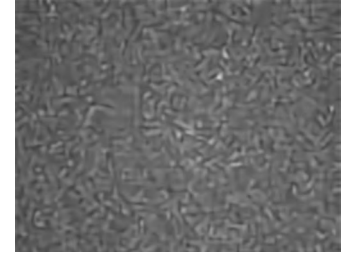

P115T

HC-P15 | HC-K25 | HC-M10

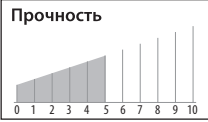
**Specification:**

Composition: Co 5.8 %; mixed carbides 6.4 %; WC balance | Grain size: 1 - 2 μm | Hardness: HV30 1550 |

Coating specification: CVD TiCN-Al₂O₃

Recommended application: The wear-resistant high-performance grade for steel machining.

Состав: Co 5.8%; соединения карбидов 6.4%; WC остальное; Размер зерна: 1 - 2 μm ;
Твердость: HV 1550;

Состав покрытия: CVD Ti (C,N) + Al₂O₃; 18.5 μm ;

Рекомендуемое применение: Износостойкий, высокопроизводительный сплав для чистовой и получистовой обработки стали.

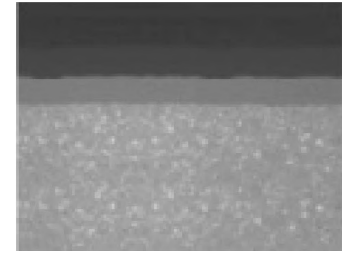

P125T

HC-P25 | HC-K30 | HC-M20

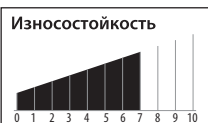
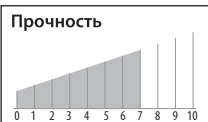
**Specification:**

Composition: Co 7.0 %; mixed carbides 8.0 %; WC balance | Grain size: 1 - 2 μm | Hardness: HV30 1450 | Coating specification: CVD TiCN-Al₂O₃

Recommended application: The first choice for the universal machining of steel.

Состав: Co 7.0%; соединения карбидов 8.0%; WC остальное; Размер зерна: 1 - 2 μm ;
Твердость: HV 1450;

Состав покрытия: CVD Ti (C,N) + Al₂O₃; 15 μm ;

Рекомендуемое применение: Износостойкий, высокопроизводительный сплав для чистовой и получистовой обработки стали.

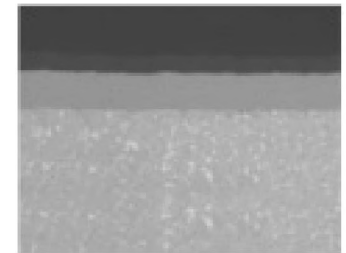

P125GP

HC-P25 | HC-K30 | HC-20

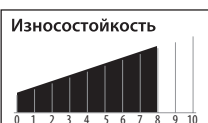
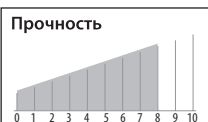
**Specification:**

Composition: Co 7.6 %; mixed carbides 7.0 %; others 0.4 %; WC balance | Grain size: 1-2mm | Hardness: HV30 1470 | Coating specification: CVD TiCN-Al₂O₃ Top layer

Recommended application: The first and premium choice for the universal machining of steel.

Состав: Co 7.6 %; соединения карбидов 7.0 %; WC остальное; Размер зерна: 1-2mm
Твердость: HV30 1470, Состав покрытия: CVD TiCN-Al₂O₃ верхний слой

Рекомендуемое применение: Первый выбор для получистовой обработки стали.

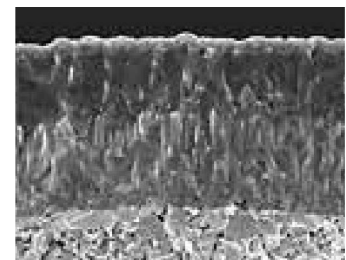

P135T

HC-P35 | HC-M25 | HC-S25

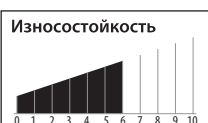
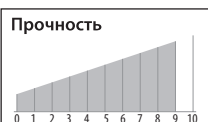
**Specification:**

Composition: Co 9.6 %; mixed carbides 6.7 %; WC balance | Grain size: 1 - 2 μm | Hardness: HV30 1460 | Coating specification: CVD TiCN-Al₂O₃ multi-layer

Recommended application: The tough alternative for heavily interrupted cutting action.

Состав: Co 9.6%; соединения карбидов 6.7%; WC остальное; Размер зерна: 1 - 2 μm ;
Твердость: HV 1460; Состав покрытия: CVD Ti (C,N) + Al₂O₃ многослойный;

Рекомендуемое применение: Для тяжелого прерывистого точения.

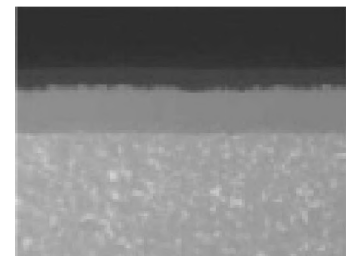

M120T

HC-M20 | HC-K20

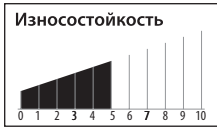
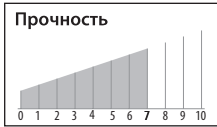

Specification:
Composition: Co 10.5 %; mixed carbide 2.0 %; WC balance | Grain size: 1-2 μm | Hardness: HV30 1400 | Coating specification: PVD TiAlTaN
Recommended application: Particularly suitable for the wet machining of steels.

Состав: Со 10.5%; соединения карбидов 2.0%; WC остальное; Размер зерна: 1-2μm;
 Твердость: HV 1400; Состав покрытия: PVD TiAlN; 2 - 5μm;
Рекомендуемое применение: Применяется для чистовой и получистовой обработки нержавеющей стали и чистовой обработки жаропрочных сплавов.

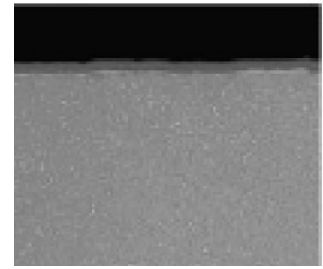

M120GP

HC-M20 | HC-P30

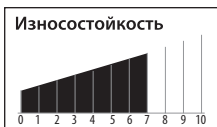
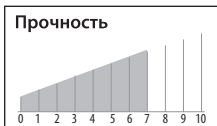

Specification:
Composition: Co 9.6 %; mixed carbides 7.8 %; others 0.4 %; WC balance | Grain size: 1 - 2 μm | Hardness: HV30 1460 | Coating specification: PVD TiAlTaN
Recommended application: The first choice for the machining of austenitic steels.

Состав: Со 9.6%; соединения карбидов 7.8%; WC остальное; Размер зерна: 1-2μm;
 Твердость: HV 1460; Состав покрытия: PVD TiN/TiAlN; 6μm;
Рекомендуемое применение: Сплав разработан для обработки аустенитной нержавеющей стали.

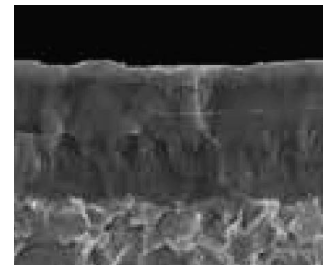

M125T

HC-M20 | HC-K20

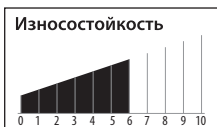
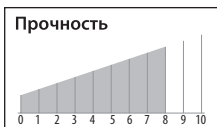

Specification:
Composition: Co 9.6 %; mixed carbides 7.8%; WC balance | Grain size: 1-2 μm | Hardness: HV₃₀ 1460 | Coating specifications: PVD TiAlTaN
Recommended application: Universal stainless steel turning grade. The best in difficult situations.

Состав: Со 9.6%; соединения карбидов 7.8%; WC остальное; Размер зерна: 1.0-2.0 μm;
 Твердость: HV₃₀ 1330; Состав покрытия: PVD TiAlTaN;
Рекомендуемое применение: Получистовое точение нержавеющей стали.

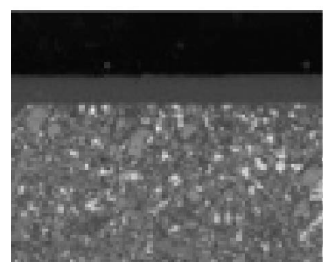

M135T

HC-P35 | HC-M35

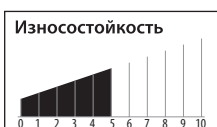
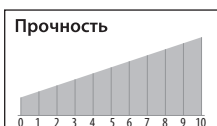

Specification:
Composition: Co 8.0 %; WC balance; mixed carbides 4.2 %; Grain size: 1.5-3.0 μm | Hardness: HV30 1330
Recommended application: Universal stainless steel turning grade. The best in difficult situations.

Состав: Со 8.0%; соединения карбидов 4.2%; WC остальное; Размер зерна: 1.5-3.0 μm;
 Твердость: HV30 1330; Состав покрытия: PVD TiN/TiAlN; 6μm;
Рекомендуемое применение: Получерновое точение нержавеющей стали.

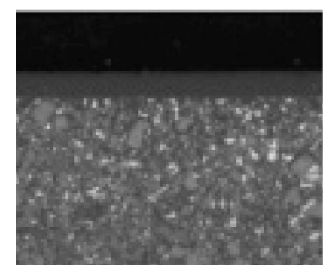

M217T

HC-M15 | HC-S15

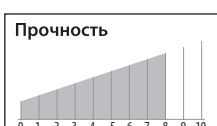

Specification:
Composition: Co 6.0 %; WC balance | Grain size 0.8-1.3 μm | Hardness HV30 1630 | Coating specification PVD TiAlN
Recommended application: The first choice for the machining of Stainless Steels and Exotic.

Состав: Со 6.0%; WC остальное; Размер зерна: 0.8-1.3 μm; Твердость: HV30 1630;
 Состав покрытия: PVD TiAlN;
Рекомендуемое применение: Первый выбор для обработки нержавеющей стали и жаропрочных сплавов

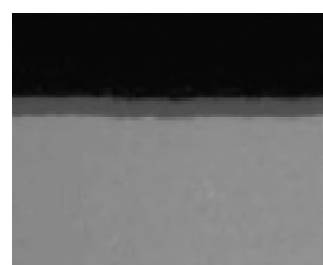

K110GP

HC-K10 | HC-P05



Specification:
Composition: Co 5.0 %; mixed carbide 2.0 %; WC balance | Grain size: submicron | Hardness: HV30 1810 | Coating specification: CVD TiCN-Al₂O₃
Recommended application: The wear-resistant grade for the machining of cast iron at highcutting speed with continuous cut.

Состав: Со 5.0 %; соединения карбидов 2.0 %; WC остальное; Размер зерна: submicron, Твердость: HV30 1810; Состав покрытия: CVD TiCN-Al₂O₃;
Рекомендуемое применение: Износостойкий сплав для обработки чугуна на высокой скорости резания

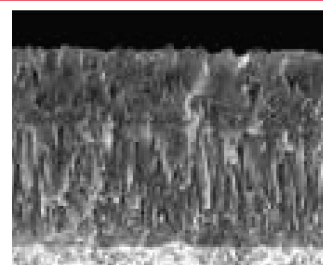

K120T

HC-K20 | HC-P10

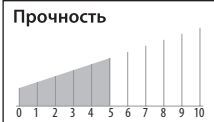
**Specification:**

Composition: Co 6.0 %; TaC 2.0 %; WC balance | Grain size: 1 μm | Hardness: HV30 1630 |
Coating specification: CVD TiCN-Al₂O₃

Recommended application:

The first choice for the machining of cast iron at high cutting speeds and where high toughness is required.

Состав: Со 6.0%; ТаС 2.0%; WC остальное; Размер зерна: 1 μm ; Твердость: HV 1630;
Состав покрытия: CVD TiCN-Al₂O₃; 15.5 μm ;

Рекомендуемое применение: Сплав для полустойкой обработки чугуна на высоких скоростях резания, где требуется твердость.

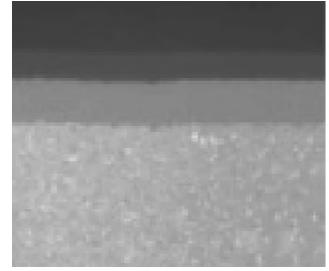

N216T

HW-N15 | HW-K15

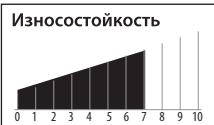
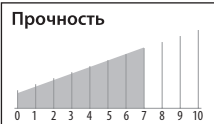

Composition: Co 6.0%; WC balance | Grain size: 1 μm | Hardness: HV30 1630

Recommended application:

The uncoated carbide grade for the machining of aluminium and other non-ferrous metals

Состав: Со 6.0%; WC остальное; Размер зерна: 1 μm ; Твердость: HV 1630; Состав покрытия: Без покрытия

Рекомендуемое применение: Непокрытый сплав для обработки алюминия и других цветных металлов.

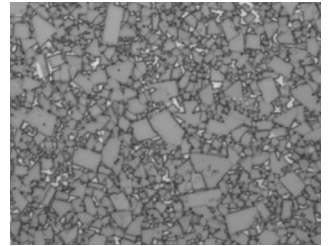

S110T

HC-S15 | HC-M15

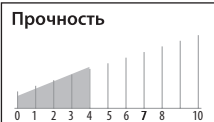

Composition: Co 6.0%; WC balance | Grain size: 0.8 μm | Hardness: HV30 1820 |

Coating specification: PVD TiAlN

Recommended application:

The alternative when machining heat-resistant materials

Состав: Со 6.0%; WC остальное; Размер зерна: 0.8 μm ;
 Твердость: HV 1820; Состав покрытия: PVD TiAlN; 4 μm ;

Рекомендуемое применение: Для полустойкой обработки жаропрочных сплавов.

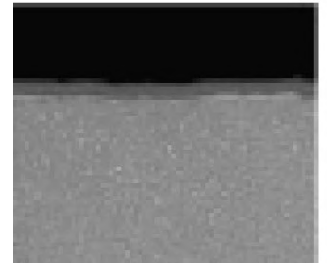

S115T

HC-S15 | HC-M15

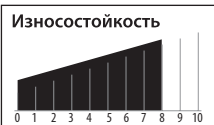
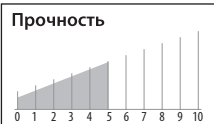

Composition: Co 6.0%; WC balance | Grain size: 0.8 μm | Hardness: HV30 1820 |

Coating specification: PVD TiAlN-TiN

Recommended application:

The first choice for the machining of heat-resistant materials

Состав: Со 6.0%; WC остальное; Размер зерна: 0.8 μm ;
 Твердость: HV 1820; Состав покрытия: PVD TiAlN-TiN; 4 μm ;

Рекомендуемое применение: Первый выбор для обработки жаропрочных сплавов.

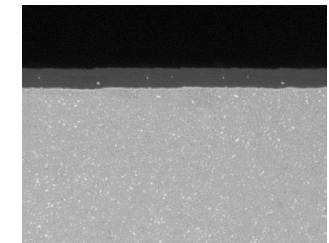

Grades/ Сплавы	ISO	Cutting material Режущий материал	Application/ Область применения										P Steel Сталь	M Stainless steel Нержавеющая сталь	K Cast iron Чугун	N Aluminium Легкие сплавы	S Superalloy Жаропрочные сплавы		
			01	05	10	15	20	25	30	35	40	45						50	
TC 10	HC-P15	T													●				
	HC-M10	T														●			
	HC-K10	T															○		
P115T	HC-P15	C													●				
	HC-K25	C															○		
	HC-M10	C																○	
P125T	HC-P25	C													●				
	HC-K30	C															○		
	HC-M20	C																○	
P125GP	HC-P25	C													●				
	HC-K30	C															○		
	HC-M20	C																○	
P135T	HC-P35	C													●				
	HC-M25	C															○		
	HC-S25	C																	○
M120T	HC-M20	P															●		
	HC-K20	P																○	
M125T	HC-M25	P													●				
	HC-P35	P																	
	HC-S25	P																	○
M120GP	HC-M20	P															●		
	HC-P25	P																	
M135T	HC-P35	P															●		
	HC-S35	P																	
M217T	HC-M15	P															●		
	HC-S15	P																○	○
K110GP	HC-K10	C																●	
	HC-P05	C															○		
K120T	HC-K20	C																●	
	HC-P10	C																○	
N216T	HW-N15	W																	●
	HW-K15	W																●	
S110T	HC-S15	P																	●
	HC-M15	P																○	
S115T	HC-S15	P																	●
	HC-M15	P																○	

*** РЕЖУЩИЙ МАТЕРИАЛ / CUTTING MATERIAL**

T - cermet/кермет без покрытия
 C - with CVD coating/сплав с покрытием CVD
 P - with PVD coating/сплав с покрытием PVD
 W - without coating/сплав без покрытия

● **First choice**
 Наилучшее применение
 ○ **Second choice**
 Допустимое применение

Positive angle

Пластины с положительным задним углом

Insert picture Изображение пластин	Chipbreaker Стружколом	Description Описание	Grades Сплавы	Types of cutting Вид резания			Types of machining Вид обработки			Depth of cut and feed rate Глубина резания и подача (mm)	
				Consistent cutting depth Постоянная глубина	Inconsistent cutting depth Переменная глубина	Interrupted cut Прерывистое	Roughing Черновая	Medium Получистовая	Finishing Чистовая		
	UJF	Finishing machining of steel and stainless steel. High surface quality. Good chip control at small depths of cut. Reduce temperature and stress. Чистовая обработка стали и нержавеющей стали. Высокое качество поверхности. Хороший контроль над стружкодроблением при небольшой глубине резания. Низкая сила резания. Низкая температура в зоне резания.	TC10	●	X	X					
	FA	Fine finishing machining of steel and stainless steel. High surface quality. Финишная обработка стали и нержавеющей. Высокое качество обработанной поверхности. With the same feed rate an insert with Master finish cutting edge reaches a roughness value Ra which is many times higher than the one of a conventional insert. При одинаковой скорости подачи режущая кромка пластины достигает значения шероховатости Ra, которое во много раз превышает значение шероховатости обычной пластины.	P125T	●	○	X					
			M135T	●	○	○					
	WF+	Finishing and semi-finishing machining Of steel and stainless steel. Great capabilities with dual chipbraker. Чистовая и получистовая обработка стали и нержавеющей стали. Широкие возможности благодаря двойному стружколому.	P115T	●	○	X		△	▲		
			P125T	●	○	X		△	▲		
			M125T	●	○	X		△	▲		
	W+	Semi-finishing-finishing machining Universal application. Reduce temperature and stress Универсальное применение. Низкая сила резания. Низкая температура в зоне резания.	P115T	●	○	X		▲	△		
			P125T	●	●	○		▲	△		
			P135T	●	●	○		▲			
			M125T	●	●	X		▲	△		
			M135T	●	●	●		▲	▲		
			K120T	●	●	X		▲	△		
	FN-F*	Finishing machining of steel. High quality of the processed surface. Чистовая обработка нержавеющей стали. Высокое качество обрабатываемой поверхности.	M120T	●	X	X					
	FN-MF+	Finishing machining of stainless steel. Increased life expectancy. Semi-finishing of aluminum. Small feedrate in bar turning. Low tendency to vibration Easy chip removal. Чистовая обработка нержавеющей стали. Получистовая обработка алюминия. Увеличенный срок службы. Низкая сила резания. Низкая склонность к вибрации. Легкое удаление стружки.	M217T	●	○	X					
			N216T	●	●	○		▲	▲		

● Первое применение

▲ Первое применение

○ Возможное применение

△ Возможное применение

X Не рекомендуется

Negative angle







Пластины с отрицательным задним углом

Insert picture Изображение пластин	Chipbreaker Стружколом	Description Описание	Grades Сплавы	Types of cutting Вид резания			Types of machining Вид обработки			Depth of cut and feed rate Глубина резания и подача (мм)
				Consistent cutting depth Постоянная глубина	Inconsistent cutting depth Переменная глубина	Interrupted cut Прерывистое	Roughing Черновая	Medium Получистовая	Finishing Чистовая	
	UJF	Finishing machining of steel and stainless steel. Increased life expectancy. Cermet inserts. Good chip control at small depth of cut. Чистовая обработка стали и нержавеющей стали. Высокое качество обрабатываемой поверхности. Хороший контроль над стружкодроблением при небольшой глубине резания. Низкая сила резания.	TC10	●	X	X			▲	
	FA	Fine finishing machining of steel. Финишная обработка стали.	P115T	●	X	X			▲	
	WL+	Semi-finishing-finishing machining of steel. Increase life time Переходная чистовая- получистовая обработка стали. Увеличенный срок службы.	P115T	●	○	X		△	▲	
			P125T	●	○	X		△	▲	
	W+	The first choice for semi-finishing machining steel. Первый выбор для получистовой обработки стали.	P115T	●	○	X		▲		
			P125T	●	●	○		▲		
			P125GP	●	●	○		▲		
			P135T	●	●	●		▲		
			K120T	●	○	X		▲		
	UWR+	Roughing steel. Черновая обработка стали.	P115T	●	●	○	▲	▲		
			P125T	●	●	○	▲	▲		
			P135T	●	●	○	▲	△		
	EN-T	Semi-finishing machining steel. Получистовая обработка стали.	P125T	●	●	○			△	
	EN-H2	One-way insert. Single Sided roughing geometry Good chip control. For steels with high strength (800N/mm ²) Односторонняя пластина. Переходная получистовая черновая обработка стали с прочностью 800N/mm². Работа на высокой подаче и с большой глубиной резания. Тяжелое прерывистое резание. Низкая сила резания.	P115T	●	●	○	△	▲		
			P125T	●	●	●	△	▲		
			P135T	●	●	●	△	▲		

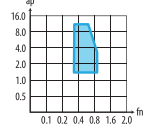
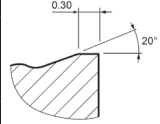
- Первое применение ▲ Первое применение
- Возможное применение △ Возможное применение
- X Не рекомендуется

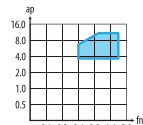
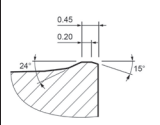
Negative angle

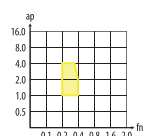
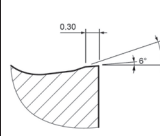
Пластины с отрицательным задним углом

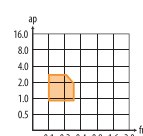
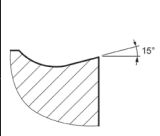
Insert picture Изображение пластин	Chipbreaker Стружколом	Description Описание	Grades Сплавы	Types of cutting Вид резания			Types of machining Вид обработки			Depth of cut and feed rate Глубина резания и подача (mm)	
				Consistent cutting depth Постоянная глубина	Inconsistent cutting depth Переменная глубина	Interrupted cut Прерывистое	Roughing Черновая	Medium Получистовая	Finishing Чистовая		
	EN-H5	One-way insert. Medium and roughing machining. Low cutting force. Universal geometry for almost all materials. Suitable for unstable working conditions due to low cutting force.	P115T	●	●	○	▲	▲		 	
		Односторонняя пластина. Переходная получистовая-черновая обработка стали. Низкая сила резания. Универсальная геометрия для практически всех материалов. Подходит для нестабильных условий работы благодаря низкой силе резания.	P125T	●	●	○	▲	▲			
		P135T	●	●		▲	▲				
	SN-H8	One-way insert. Heavy steel turning. Work at a deep cutting depth. Designed for heavy, intermittent handling.	P125T	●	●	●	▲			 	
	R+	Roughing stainless steel processing. Low cutting force.	M125T	●	●	○	▲	▲		 	
	E+	Low cutting force. The first choice for semi-finishing processing of superalloys.	S110T	●	○	×	▲	△		 	
		Низкая сила резания. Первый выбор для получистовой обработки жаропрочных сплавов.	S115T	●	○	×	▲	△			

- Первое применение ▲ Первое применение
○ Возможное применение △ Возможное применение
X Не рекомендуется

Negative angle

Пластины с отрицательным задним углом

Insert picture Изображение пластин	Chipbreaker Спружолом	Description Описание	Grades Сплавы	Types of cutting Вид резания			Types of machining Вид обработки			Depth of cut and feed rate Глубина резания и подача (mm)	
				Consistent cutting depth Постоянная глубина	Inconsistent cutting depth Переменная глубина	Interrupted cut Прерывистое	Roughing Черновая	Medium Получистовая	Finishing Чистовая		
	90	Roughing and semi-finishing steel. Universal use. Черновая и получистовая обработка стали и чугуна Универсальное применение.	P125T	●	○	X	▲	▲			
			P135T	●	●	○	▲	▲			
			K120T	●	○	X	▲	▲			
	UEN	Semi-finish, easy roughing of nodular cast iron. Получистовая, легкая черновая обработка чугуна с шаровидным графитом.	K120T	●	●	○	△	▲			
	SN-R	Rough and semi-finishing steel processing. Universal application. Черновая и получистовая обработка стали. Универсальное применение.	P125T	●	○	X	△	▲			
			P135T	●	●	○	▲	▲			
	M1	Semi-finishing machining of steel. Получистовая обработка стали.	P125T	●	○	X		▲			
	XK	Finishing machining of stainless steel and titanium alloys. Чистовая обработка нержавеющей стали и титановых сплавов.	M120T	●	○	X		▲			
	K+	Semi-finishing stainless steel processing. Low probability of formation of surface defects. High quality of the processed surface. Low cutting force. High cutting parameters with constant cooling. Получистовая обработка нержавеющей стали. Низкая вероятность образования поверхностных дефектов. Высокое качество обрабатываемой поверхности. Низкая сила резания. Высокие параметры резания при условии постоянного охлаждения.	M125T	●	●	○		▲			
			M120GP	●	●	○		▲			

- Первое применение ▲ Первое применение
- Возможное применение △ Возможное применение
- X Не рекомендуется

A series of horizontal dotted lines spanning the width of the page, providing a guide for technical drawing.

Top angle Угол при вершине	35°	V	
		55°	D
	75°	E	
	80°	C	
	86°	M	
Угол при вершине	55°	K	
	82°	B	
	85°	A	
Other hapes		90°	L
		108°	P
		120°	H
		135°	O
		-	R
		90°	S
		60°	T
		80°	W
Insert shape Форма пластины			

	d±	m±	s±
	0,025	0,005	0,025
F	0,013	0,005	0,025
C	0,025	0,013	0,025
H	0,013	0,013	0,025
E	0,025	0,025	0,025
G	0,025	0,025	0,13
J	0,05-0,15*	0,005	0,025
K	0,05-0,15*	0,013	0,025
L	0,05-0,15*	0,025	0,025
M	0,05-0,15*	0,08-0,20	0,13
N	0,05-0,15*	0,08-0,20	0,025
U	0,08-0,25*	0,13-0,238	0,013
Tolerance Допуски			

C N M G







Задний угол
Normal clearance angle

3°	A	25°	F
5°	B	30°	G
7°	C	0°	N
15°	D	11°	P
20°	E		

Задний угол не включенный в стандарт, необходимо указывать дополнительно ○

Геометрия поверхностей
Type of chip breaker/clamping

N		
R		
F		
A		
M, P		
G, P		
W		
T		
Q		
U		
B		
H		
C		
J		
X	специальная форма	

		d mm			
 		06	16		
		08	20		
		10	25		
		12	32		
		   			
		mm	дюйм	mm	mm
		06	5/32	3,96	03
		09	7/32	5,56	05
		11	1/4	6,35	06
		16	3/8	9,52	09
		22	1/2	12,7	12
		27	5/8	15,8	15
		33	3/4	19,0	19
		44	1	25,4	25

Insert size
Длина режущей кромки

		Радиус закругления, мм
		≤ 0,05
		0,1
		0,2
		0,4
		0,8
		1,2
		1,6
		2,4
		3,2



 RN 00
 RC 00

Nose radius
Радиус закругления

12

04

08

Толщина пластины
Insert thickness

		Индекс
		
Дюйм	mm	
1/16	1,59	01
3/32	2,38	02
1/8	3,18	03
5/32	3,97	T3
3/16	4,76	04
7/32	5,56	05
1/4	6,35	06
5/16	7,94	07
3/8	9,52	09

CN... Negative angle

Пластины с отрицательным задним углом

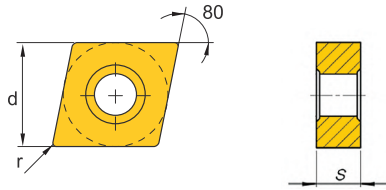

Обозначение	d	s
CN... 090...	9.52	3.18
CN... 120...	12.70	4.76
CN... 190...	19.05	6.35

Grades
Сплавы

Image of inserts Изображение пластин	Type of cutting Вид обработки	Chipbreaker Стружколом	Description Обозначение	r	P115T	P125T	TC10	M120T	M120GP	M125T	S110T	S115T	S240T	
	Finishing Чистовая	UJF	CNMG 120404-UJF	0.40			●							
			CNMG 120408-UJF	0.80			●							
	Fine finishing Финишная	NFA	CNMX 120404-NFA+	0.40	●									
			CNMX 120408-NFA+	0.80	●									
	Finishing Чистовая	XK	CNGP 120402-XK	0.20				●						
			CNGP 120404-XK	0.40				●						
			CNGP 120408-XK	0.80					●					
			CNGP 120412-XK	1.20					●					
	Finishing Чистовая- Medium-finishing Получистовая	WL+	CNMG 090304-WL+	0.40	●									
			CNMG 120404-WL+	0.40	●	●								
			CNMG 120408-WL+	0.8	●	●								
	Medium-finishing Получистовая	E+	CNMG 120404-E+	0.40							●	●		
			CNMG 120408-E+	0.80								●	●	
	Medium-finishing Получистовая	K+	CNMG 090304-K+	0.40					●	●				
			CNMG 090308-K+	0.80					●	●				
			CNMG 120404-K+	0.40					●	●				
			CNMG 120408-K+	0.80					●	●				

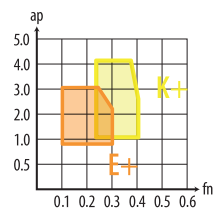
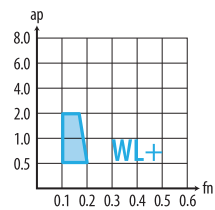
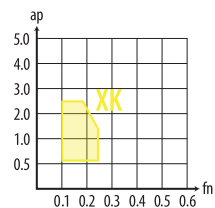
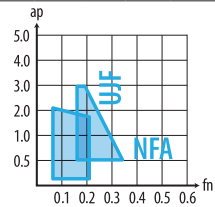

	P115T	P125T	TC10	M120T	M120GP	M125T	S110T	S115T	S240T
P Steel - Сталь	★	★	★		★	★			
M Stainless steel aust. - Аустенитная нерж. сталь	☆	☆	★	★	★	★	☆	☆	☆
K Cast iron - Чугун	★	★	☆	☆					
N Aluminium - Алюминиевые сплавы				☆					
S Hig. temp. alloy - Жаропрочные сплавы						☆	★	★	★

- ★ Best choice
Наилучшее применение
- ☆ Second choice
Допустимое применение

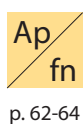
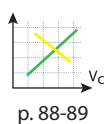

CN... Negative angle

Пластины с отрицательным задним углом

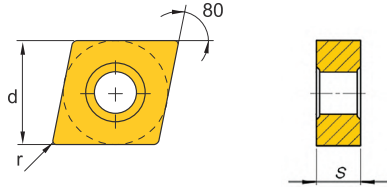

Обозначение	d	s
CN... 120...	12.70	4.76
CN... 160...	15.88	6.35
CN... 190...	19.05	6.35

Grades
Сплавы

Image of inserts Изображение пластин	Type of cutting Вид обработки	Chipbreaker Стружколом	Description Обозначение	r	Grades Сплавы							
					P115T	P125T	P125GP	P135T	M125T	K110GP	K120T	
	Medium-finishing Получистовая	W+	CNMG 120404-W+	0.40	●	●	●					
			CNMG 120408-W+	0.80	●	●	●	●			●	
			CNMG 120412-W+	1.20	●	●	●	●			●	
	Medium-roughing Получерновая	90+	CNMG 120408-90+	0.80						●	●	
			CNMG 120412-90+	1.20						●	●	
			CNMG 160608-90+	0.80				●			●	
			CNMG160612-90+	1.20		●		●		●	●	
			CNMG 190612-90+	1.20		●		●			●	
			CNMG 190616-90+	1.60		●		●			●	
	Medium-roughing Получерно- вая	UEN	CNMA 120408-UEN	0.80						●	●	
			CNMA 120412-UEN	1.20							●	
			CNMA 120416-UEN	1.60							●	
	Medium-roughing Получерновая	EN-H2	CNMM 120408-EN-H2	0.80	●	●		●				
			CNMM 120412-EN-H2	1.20		●						

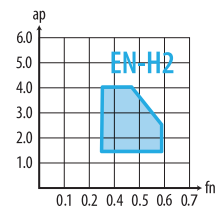
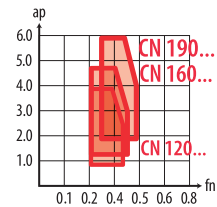
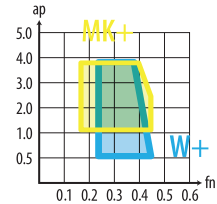

	P115T	P125T	P125GP	P135T	M125T	K110GP	K120T
P Steel - Сталь	★	★	★	★	★	☆	☆
M Stainless steel aust. - Аустенитная нерж. сталь	☆	☆	☆	☆	★		
K Cast iron - Чугун	★	★				★	★
N Aluminium - Алюминиевые сплавы							
S Hig. temp. alloy - Жаропрочные сплавы				☆	☆		

- ★ Best choice
Наилучшее применение
- ☆ Second choice
Допустимое применение

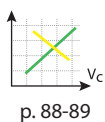

CN... Negative angle

Пластины с отрицательным задним углом

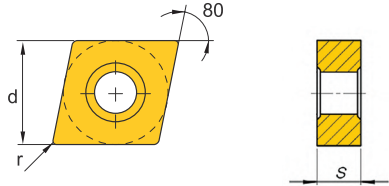

Grades
Сплавы

Обозначение	d	s
CN... 120...	12.70	4.76
CC... 160...	15.88	6.35
CC... 190...	19.05	6.35
CC... 2507...	25.40	7.94
CC... 2509...	25.40	9.52

Image of inserts Изображение пластин	Type of cutting Вид обработки	Chipbreaker Стружколом	Description Обозначение	r	P115T	P125T	P125GP	P135T	M125T	
	Medium-roughing Получерновая	UWR+	CNMG 120408-UWR+	0.80	●	●				
			CNMG 120412-UWR+	1.20		●				
	Roughing Черновая	R+	CNMG 120408-R+	0.80					●	
			CNMG 120412-R+	1.20						
	Medium-roughing Получерновая	EN-H5	CNMM 120412-EN-H5	1.20	●	●		●		
			CNMM 120416-EN-H5	1.60		●		●		
			CNMM 160612-EN-H5	1.20	●	●		●		
			CNMM 190612-EN-H5	1.20	●	●				
			CNMM 190616-EN-H5	1.60		●				
			CNMM 250724-EN-H5	2.40		●				
CNMM 250924-EN-H5	2.40		●							
	Roughing Черновая	SN-H8	CNMM 190616-SN-H8	1.6		●				
			CNMM 190624-SN-H8	2.4		●				
			CNMM 250924-SN-H8	2.4		●				
			CNMM 250932-SN-H8	3.2		●				
					P115T	P125T	P125GP	P135T	M125T	
P Steel - Сталь					★	★	★	★	★	<p>★ Best choice Наилучшее применение</p> <p>☆ Second choice Допустимое применение</p>
M Stainless steel aust. - Аустенитная нерж. сталь					☆	☆	☆	☆	★	
K Cast iron - Чугун					★	★				
N Aluminium - Алюминиевые сплавы										
S Hig. temp. alloy - Жаропрочные сплавы								☆	☆	
H Hard materials - Закаленные стали							☆			

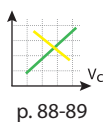

DN... Negative angle

Пластины с отрицательным задним углом

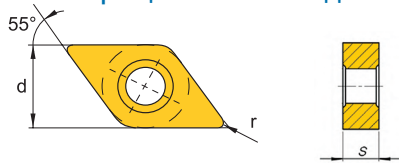

Обозначение	d	s
DN... 110...	9.52	4.76
DN... 150...	12.70	6.35

Image of inserts Изображение пластин	Type of cutting Вид обработки	Chipbreaker Стружколом	Description Обозначение	r	Grades Сплавы												
					P115T	P125T	P135T	TC10	M120T	M125T	M120GP	K120T	S110T	S115T			
	Finishing Чистовая	UJF	DNMG 110404-UJF	0.40				●									
			DNMG 150604-UJF	0.40				●									
	Fine finishing Финишная	NFA+	DNMX 150604-NFA+	0.40	●												
			DNMX 150608-NFA+	0.80	●												
	Medium-finishing Получистовая	WL+	DNMG 110404-WL+	0.40	●	●											
			DNMG 150604-WL+	0.40	●												
			DNMG 150608-WL+	0.80	●												
	Finishing Чистовая	XK	DNGP 150404-XK	0.40					●								
			DNGP 150602-XK	0.20					●								
			DNGP 150604-XK	0.40					●								
			DNGP 150608-XK	0.80					●								
	Medium-roughing Получерновая	90+	DNMG 150608-90+	0.80									●				
	Medium-finishing Получистовая	E+	DNMG 150608-E+	0.80										●	●		
	Medium-finishing Получистовая	K+	DNMG 110404-K+	0.40							●	●					
			DNMG 110408-K+	0.80							●	●					
			DNMG 150404-K+	0.40								●	●				
			DNMG 150408-K+	0.80								●	●				
			DNMG 150604-K+	0.40								●	●				
			DNMG 150608-K+	0.80								●	●				
	Roughing Черновая	R+	DNMG 150608-R+	0.80							●						
			DNMG 150612-R+	1.20							●						

	P115T	P125T	P135T	TC10	M120T	M125T	M120GP	K120T	S110T	S115T
P Steel - Сталь	★	★	★	★		★	★			
M Stainless steel aust. - Аустенитная нерж. сталь	☆	☆	☆	★	★	★	★			
K Cast iron - Чугун	★	★		☆	☆			★		
N Aluminium - Алюминиевые сплавы					☆					
S Hig. temp. alloy - Жаропрочные сплавы			☆				☆		★	★

★ Best choice
Наилучшее применение

☆ Second choice
Допустимое применение

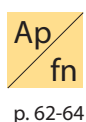
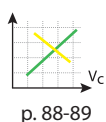

DN... Negative angle

Пластины с отрицательным задним углом

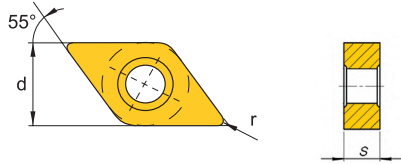

Обозначение	d	s
DN... 110...	9.52	4.76
DN... 150...	12.7	6.35

Image of inserts Изображение пластины	Type of cutting Вид обработки	Chipbreaker Стружколом	Description Обозначение	r	Grades Сплавы					
					P115T	P125T	P135T	P125GP	M125T	K120T
	Medium-finishing Получистовая	W+	DNMG 110404-W+	0.40	●	●				
			DNMG 110408-W+	0.80	●	●	●	●		
			DNMG 150404-W+	0.40		●		●		
			DNMG 150408-W+	0.80		●		●		
			DNMG 150604-W+	0.40	●	●		●		
			DNMG 150608-W+	0.80	●	●	●	●		●
DNMG 150612-W+	1.20	●	●	●	●		●			
	Medium-roughing Получерновая	UWR+	DNMG 150608-UWR+	0.80	●	●	●			
			DNMG 150612-UWR+	1.20	●	●	●			
	Medium-roughing Получерновая	EN-H5	DNMM 150612-EN-H5	1.2	●	●	●			
	Medium-roughing Получерновая	EN-H2	DNMM 150608-EN-H2	0.80	●	●	●			
					P115T	P125T	P135T	P125GP	M125T	K120T
P Steel - Сталь					★	★	★	★	★	☆
M Stainless steel aust. - Аустенитная нерж. сталь					☆	☆	☆	☆	★	
K Cast iron - Чугун					★	★				★
N Aluminium - Алюминиевые сплавы								☆		
S Hig. temp. alloy - Жаропрочные сплавы							☆		☆	

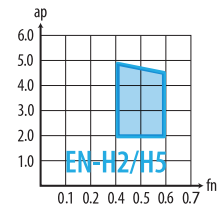
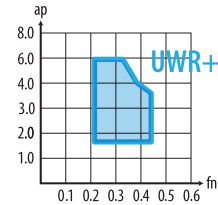
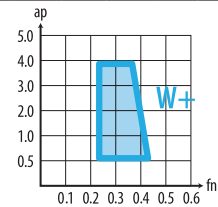

- ★ Best choice
Наилучшее применение
- ☆ Second choice
Допустимое применение

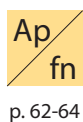
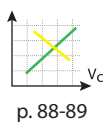

SN... Negative angle

Пластины с отрицательным задним углом

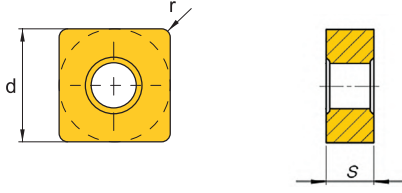

Обозначение	d	s
SN... 120...	12.70	4.76
SN... 190...	19.05	6.35
SN... 2507..	25.40	7.94

Обозначение	d	s
SN... 150...	15.88	6.35
SN... 2509..	25.40	9.52

Grades
Сплавы

Image of inserts Изображение пластин	Type of cutting Вид обработки	Chipbreaker Стружколом	Description Обозначение	r	P115T	P125T	P135T	M120T	M125T	K110GP	K120T	N216T
	Medium-roughing Получерновая	EN-H5	SNMM 190612-EN-H5	1.20	●							
			SNMM 190616-EN-H5	1.60	●							
			SNMM 250724-EN-H5	2.40	●							
			SNMM 250924-EN-H5	2.40	●							
	Medium-roughing Получерновая	UWR+	SNMG 120408-UWR+	0.80	●							
			SNMG 120412-UWR+	1.20	●							
	Medium-roughing Получерновая	90+	SNMG120408-90+	0.80						●		
			SNMG 120412-90+	1.20						●		
			SNMG 150612-90+	1.20	●	●						
			SNMG 190612-90+	1.20	●	●						
	Roughing Черновая	SN-H8	SNMM 190616-SN-H8	1.60	●							
			SNMM 190624-SN-H8	2.40	●							
			SNMM 250924-SN-H8	2.40	●							
			SNMM 250932-SN-H8	3.20	●							

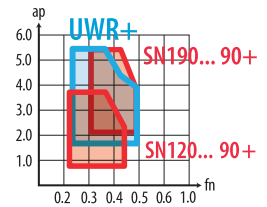
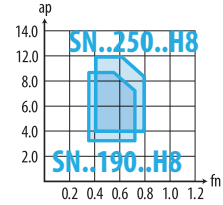

	P115T	P125T	P135T	M120T	M125T	K110GP	K120T	N216T
P Steel - Сталь	★	★	★	★	★	☆	☆	★
M Stainless steel aust. - Аустенитная нерж. сталь	☆	☆	☆	★	★			
K Cast iron- Чугун	★	★	☆	☆	★	★	★	★
N Aluminium - Алюминиевые сплавы				☆				★
S Hig. temp. alloy - Жаропрочные сплавы			☆	☆				

- ★ Best choice
Наилучшее применение
- ☆ Second choice
Допустимое применение

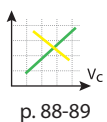

SN... Negative angle

Пластины с отрицательным задним углом

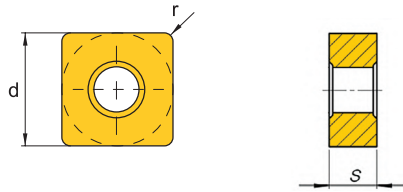

Обозначение	d	s
SN... 120...	12.70	4.76
SN... 190...	19.05	6.35
SN... 250...	25.40	9.52

Image of inserts Изображение пластин	Type of cutting Вид обработки	Chipbreaker Стружколом	Description Обозначение	r	Grades Сплавы									
					P115T	P125T	P135T	P125GP	M120GP	M125T	K120T	S110T	S115T	
	Medium-finishing Получистовая	W+	SNMG 120408-W+	0.80	●	●	●	●				●		
			SNMG 120412-W+	1.20	●	●	●							
	Medium-finishing Получистовая	EN-T	SNMM 190616-EN-T	1.60		●								
			SNMM 250924-EN-T	2.40		●								
	Medium-finishing Получистовая	E+	SNMG 120408-E+	0.80								●	●	
	Medium-finishing Получистовая	K+	SNMG 120408-K+	0.80					●	●				
	Medium-roughing Получерновая	UEN	SNMA 120408-UEN	0.80								●		

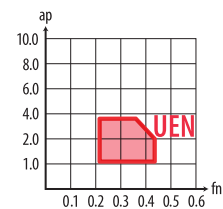
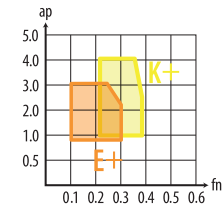
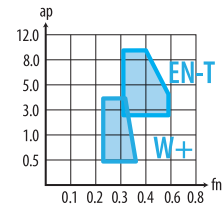

	P115T	P125T	P135T	P125GP	M120GP	M125T	K120T	S110T	S115T
P Steel - Сталь	★	★	★	★	★	★	☆		
M Stainless steel aust. - Аустенитная нерж. сталь	☆	☆	☆	☆	★	★		☆	☆
K Cast iron - Чугун	★	★					★		
N Aluminium - Алюминиевые сплавы									
S Hig. temp. alloy - Жаропрочные сплавы			☆			☆		★	★

★ Best choice
Наилучшее применение

☆ Second choice
Допустимое применение

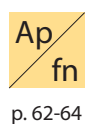
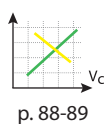

TN... Negative angle

Пластины с отрицательным задним углом

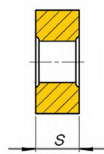
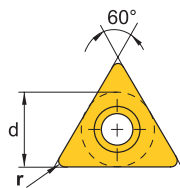

Grades
Сплавы

Обозначение	d	s
TN... 160...	9.52	4.76
TN... 220...	12.70	4.76

Image of inserts Изображение пластин	Type of cutting Вид обработки	Chipbreaker Стружколом	Description Обозначение	r	Grades Сплавы											
					P115T	P125T	P125GP	P135T	M120GP	M125T	K120T	S110T	S115T			
	Medium-finishing Получистовая	W+	TNMG 160404-W+	0.40	●	●										
			TNMG 160408-W+	0.80	●	●	●	●				●				
			TNMG 160412-W+	1.20	●	●						●				
			TNMG 220404-W+	0.40		●										
			TNMG 220408-W+	0.80		●						●				
	Medium-finishing Получистовая	E+	TNMG 160408-E+	0.80									●	●		
	Medium-finishing Получистовая	K+	TNMG 160404-K+	0.40					●	●						
	Medium-finishing Получистовая	K+	TNMG 160408-K+	0.80					●	●						
	Medium-roughing Получерновая	90+	TNMG 160408-90+	0.80							●					
	Medium-roughing Получерновая	90+	TNMG 220412-90+	1.20		●										
	Medium-roughing Получерновая	UEN	TNMA 160408-UEN	0.80									●			
	Medium-roughing Получерновая	UWR+	TNMG 160408-UWR+	0.80		●										
	Medium-roughing Получерновая	UWR+	TNMG 160412-UWR+	1.20		●										
	Medium-roughing Получерновая	R+	TNMG 160408-R+	0.80						●						
	Medium-roughing Получерновая	R+	TNMG 160412-R+	1.20						●						
					P115T	P125T	P125GP	P135T	M120GP	M125T	K120T	S110T	S115T			
P Steel - Сталь					★	★	★	★	★	★	☆					
M Stainless steel aust. - Аустенитная нерж. сталь					☆	☆	☆	☆	★	★		☆	☆			
K Cast iron- Чугун					★	★					★					
N Aluminium - Алюминиевые сплавы																
S Hig. temp. alloy - Жаропрочные сплавы								☆		☆		★	★			

- ★ Best choice
Наилучшее применение
- ☆ Second choice
Допустимое применение

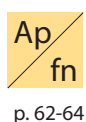
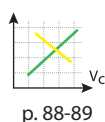

VN... Negative angle

Пластины с отрицательным задним углом

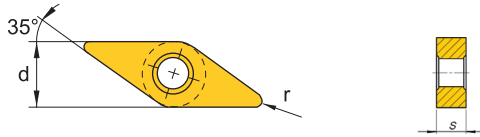

Обозначение	d	s
VN... 160...	9.52	4.76

Image of inserts Изображение пластин	Type of cutting Вид обработки	Chipbreaker Стружкололом	Description Обозначение	r	Grades Сплавы													
					P115T	P125T	P135T	TC10	M120T	M120GP	M125T	M135T	S110T	S115T				
	Medium-finishing Получистовая-чистовая	WL+	VNMG 160404-WL+	0.40	●													
	Finishing Чистовая	XK	VNGP 160402-XK	0.20					●									
			VNGP 160404-XK	0.40						●								
	Medium-finishing Получистовая	W+	VNMG 160404-W+	0.40	●	●												
			VNMG 160408-W+	0.80	●	●												
	Medium-finishing Получистовая	E+	VNMG 160408-E+	0.80										●	●			
	Medium-finishing Получистовая	K+	VNMG 160408-K+	0.80						●	●							
					P115T	P125T	P135T	TC10	M120T	M120GP	M125T	M135T	S110T	S115T				
P Steel - Сталь					★	★	★	★		★	★	☆						
M Stainless steel aust. - Аустенитная нерж. сталь					☆	☆	☆	★	★	★	★	★	☆	☆				
K Cast iron - Чугун					★	★		☆	☆					★				
N Aluminium - Алюминиевые сплавы									☆									
S Hig. temp. alloy - Жаропрочные сплавы							☆		☆		☆		★	★				

- ★ Best choice
Наилучшее применение
- ☆ Second choice
Допустимое применение

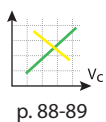

WN... Negative angle

Пластины с отрицательным задним углом

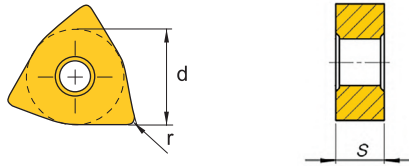

Обозначение	d	s
WN... 060...	9.52	4.76
WN... 080...	12.7	4.76

Image of inserts Изображение пластин	Type of cutting Вид обработки	Chipbreaker Стружколом	Description Обозначение	r	Grades Сплавы											
					P115T	P125T	P125GP	P135T	M120T	K110GP	K120T	S110T	S115T			
	Medium-Finishing Получистовая-чистовая	WL+	WNMG 060404-WL+	0.40	●											
			WNMG 080404-WL+	0.40	●											
	Fine finishing Финишная	NFA+	WNMX 080404-NFA+	0.40	●											
			WNMX 080408-NFA+	0.80	●											
	Finishing Чистовая	XK	WNGP 080404-XK	0.40					●							
			WNGP 080408-XK	0.80					●							
	Medium-finishing Получистовая	W+	WNMG 060404-W+	0.40	●	●										
			WNMG 060408-W+	0.80	●	●										
			WNMG 080404-W+	0.40	●	●	●									
			WNMG 080408-W+	0.80	●	●	●	●			●					
			WNMG 080412-W+	1.20	●	●	●	●			●					
	Medium-roughing Получерновая	90+	WNMG 080408-90+	0.80						●	●					
			WNMG 080412-90+	1.20						●	●					
	Medium-finishing Получистовая	E+	WNMG 080408-E+	0.80								●	●			
					P115T	P125T	P125GP	P135T	M120T	K110GP	K120T	S110T	S115T			
P Steel - Сталь					★	★	★	★	☆	☆	☆					
M Stainless steel aust. - Аустенитная нерж. сталь					☆	☆	☆	☆	★			☆	☆			
K Cast iron - Чугун					★	★		★	☆	★	★					
N Aluminium - Алюминиевые сплавы																
S Hig. temp. alloy - Жаропрочные сплавы									☆			★	★			

★ Best choice
Наилучшее применение
☆ Second choice
Допустимое применение

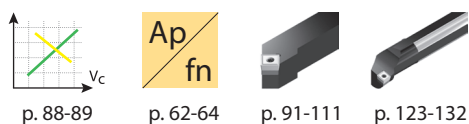

WN... Negative angle

Пластины с отрицательным задним углом

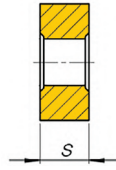
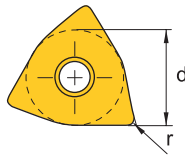

Обозначение	d	s
WN... 060...	9.53	3.97
WN... 080...	12.70	4.76

Image of inserts Изображение пластин	Type of cutting Вид обработки	Chipbreaker Стружколом	Description Обозначение	r	Grades Сплавы								
					P115T	P125T	M120T	M120GP	M125T	M135T	K110GP	K120T	N216T
	Medium-finishing Получистовая	K+	WNMG 060404-K+	0.40				●	●				
			WNMG 060408-K+	0.80				●	●				
			WNMG 080404-K+	0.40				●	●				
			WNMG 080408-K+	0.80				●	●				
			WNMG 080412-K+	1.20					●				
	Medium-roughing Получерновая	UEN	WNMA 080408-UEN	0.80							●	●	
	Medium-roughing Получерновая	UWR+	WNMG 080408-UWR+	0.80		●							
			WNMG 080412-UWR+	1.20		●							
	Roughing Черновая	R+	WNMG 080408-R+	0.80					●				
			WNMG 080412-R+	1.20					●				
					P115T	P125T	M120T	M120GP	M125T	M135T	K110GP	K120T	N216T
P Steel - Сталь					★	★		★	★	☆		☆	
M Stainless steel aust. - Аустенитная нерж. сталь					☆	☆	★	★	★	★			
K Cast iron - Чугун					★	★	☆				★	★	
N Aluminium - Алюминиевые сплавы							☆						
S Hig. temp. alloy - Жаропрочные сплавы									☆				

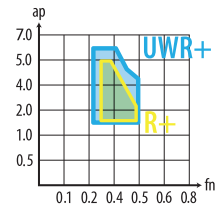
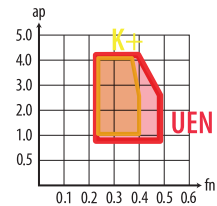

- ★ Best choice
Наилучшее применение
- ☆ Second choice
Допустимое применение

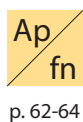
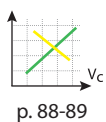

KN...

Negative angle

Пластины с отрицательным задним углом

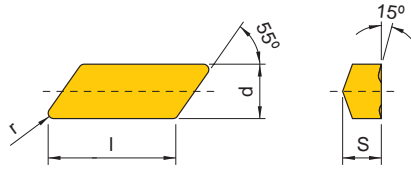

Обозначение	d	s	L
KN... 160...	9.52	4.76	16.0

Image of inserts Изображение пластин	Type of cutting Вид обработки	Chipbreaker Стружколом	Description Обозначение	r	Grades Сплавы												
					P115T	P125T	P135T	TC10	M120T	M125T	M135T	M217T	S110T	S115T			
	Medium-finishing Получистовая	M1	KNUX 160405L-M1	0.50		●				●	●						
			KNUX 160405R-M1	0.50		●				●	●						
			KNUX 160410L-M1	1.00		●											
			KNUX 160410R-M1	1.00		●											

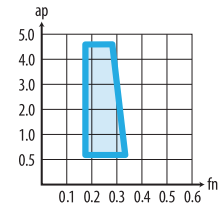

	P115T	P125T	P135T	TC10	M120T	M125T	M135T	M217T	S110T	S115T
P Steel - Сталь	★	★	★			★				
M Stainless steel aust. - Аустенитная нерж. сталь	☆	☆	☆		★	★			☆	☆
K Cast iron - Чугун	☆	★	★		☆					
N Aluminium - Алюминиевые сплавы					☆					
S Hig. temp. alloy - Жаропрочные сплавы						☆			★	★

- ★ Best choice
Наилучшее применение
- ☆ Second choice
Допустимое применение

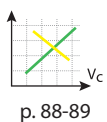

CC... Positive angle
Пластины с положительным задним углом

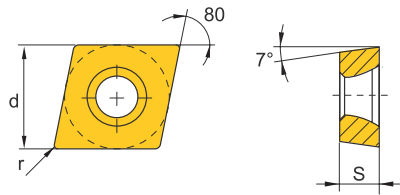

Обозначение	d	s
CC... 0602...	6.35	2.38
CC... 09T3...	9.52	3.97
CC... 1204...	12.7	4.76

Image of inserts Изображение пластин	Type of cutting Вид обработки	Chipbreaker Стружколом	Description Обозначение	r	Grades Сплавы															
					P115T	P125T	P125GP	P135T	TC10	M120T	M120GP	M125T	M135T	K120T		N216T	M217T			
	Finishing Чистовая	UJF	CCMT 060204-UJF	0.40					●											
			CCMT 09T304-UJF	0.40					●											
	Fine finishing Финишная	FA	CCMX 09T304-FA	0.40		●								●						
			CCMX 09T308-FA	0.80		●									●					
	Finishing-Medium Чистовая-получистовая	WF+	CCMT 060202-WF+	0.20		●	●					●	●							
			CCMT 060204-WF+	0.40	●	●	●					●	●							
			CCMT 09T302-WF+	0.20		●	●						●	●						
			CCMT 09T304-WF+	0.40		●	●	●					●	●						
			CCMT 09T308-WF+	0.80		●	●	●					●	●						
	Finishing Чистовая	FN-F	CCGT 060200-FN-F	0.05							●									
			CCGT 060201-FN-F	0.10								●								
			CCGT 09T300-FN-F	0.05									●							
			CCGT 09T301-FN-F	0.10									●							
	Medium-finishing Получистовая	W+	CCMT 060204-W+	0.40	●	●	●	●				●	●			●				
			CCMT 060208-W+	0.80	●	●	●	●				●	●							
			CCMT 09T304-W+	0.40	●	●	●	●				●	●	●	●					
			CCMT 09T308-W+	0.80	●	●	●	●				●	●	●	●					
			CCMT 120404-W+	0.40		●	●					●	●							
			CCMT 120408-W+	0.80		●	●					●	●			●				
			CCMT 120412-W+	1.20		●	●						●							
	Medium-finishing Получистовая	FN-MF+	CCGT 060201-FN-MF+	0.10												●	●			
			CCGT 060202-FN-MF+	0.20													●		●	
			CCGT 060204-FN-MF+	0.40															●	●
			CCGT 09T302-FN-MF+	0.20															●	●
			CCGT 09T304-FN-MF+	0.40															●	●
			CCGT 09T308-FN-MF+	0.80															●	●
			CCGT 120404-FN-MF+	0.40															●	●
			CCGT 120408-FN-MF+	0.80															●	●

★ Best choice
Наилучшее применение
☆ Second choice
Допустимое применение

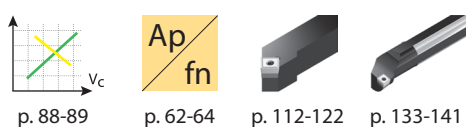

р. 88-89

р. 62-64

р. 112-122

р. 133-141

DC... Positive angle

Пластины с положительным задним углом

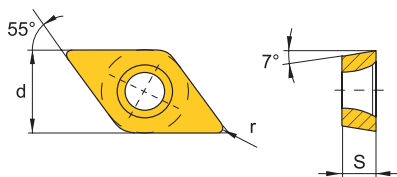

Обозначение	d	s
DC... 070...	6.35	2.48
DC... 11T...	9.52	3.97

Image of inserts Изображение пластин	Type of cutting Вид обработки	Chipbreaker Стружколом	Description Обозначение	r	Grades Сплавы														
					P115T	P125T	P125GP	P135T	TC10	M120T	M120GP	M125T	M135T	K120T	N216T	M217T			
	Finishing Чистовая	UJF	DCMT 070204-UJF	0.40					●										
			DCMT 11T304-UJF	0.40					●										
	Fine finishing Финишная	FA	DCMX 070204-FA	0.40		●													
			DCMX 11T304-FA	0.40		●						●							
			DCMX 11T308-FA	0.80		●							●						
	Finishing-Medium Чистовая-полу- чистовая	WF+	DCMT 070202-WF+	0.20		●	●				●	●							
			DCMT 070204-WF+	0.40	●	●	●				●	●							
			DCMT 11T302-WF+	0.20		●	●					●	●						
			DCMT 11T304-WF+	0.40	●	●	●					●	●						
			DCMT 11T308-WF+	0.80		●	●						●						
	Finishing Чистовая	FN-F	DCGT 070200-FN-F	0.05						●									
			DCGT 070201-FN-F	0.10							●								
			DCGT 11T300-FN-F	0.05								●							
			DCGT 11T301-FN-F	0.10								●							
	Medium-finish Получистовая	W+	DCMT 070204-W+	0.40		●	●	●			●	●		●					
			DCMT 070208-W+	0.80		●		●				●	●						
			DCMT 11T304-W+	0.40	●	●	●	●				●	●	●	●				
			DCMT 11T308-W+	0.80	●	●	●	●					●	●	●	●			
	Medium-finish Получистовая	FN-MF+	DCGT 070201-FN-MF+	0.10											●	●			
			DCGT 070202-FN-MF+	0.20												●		●	
			DCGT 070204-FN-MF+	0.40														●	●
			DCGT 070208-FN-MF+	0.80														●	●
			DCGT 11T302-FN-MF+	0.20														●	●
			DCGT 11T304-FN-MF+	0.40														●	●
			DCGT 11T308-FN-MF+	0.80														●	●

	P115T	P125T	P125GP	P135T	TC10	M120T	M120GP	M125T	M135T	K120T	N216T	M217T
P Steel - Сталь	★	★	★	★	★		★	★	☆	☆		
M Stainless steel aust. - Аустенитная нерж. сталь	☆	☆	☆	☆	★	★	★	★	★			★
K Cast iron - Чугун	★	★	★		☆	☆				★	★	
N Aluminium - Алюминиевые сплавы						☆					★	
S Hig. temp. alloy - Жаропрочные сплавы				☆				☆				★

- ★ Best choice
Наилучшее применение
- ☆ Second choice
Допустимое применение

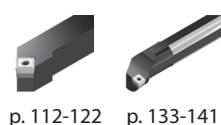
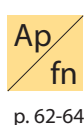
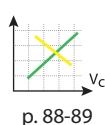

SC... Positive angle
Пластины с положительным задним углом

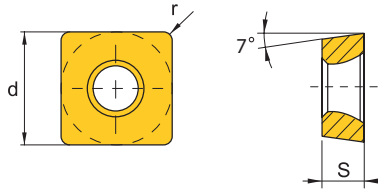

Обозначение	d	s
SC... 09T...	9.52	3.97
SC... 120...	12.7	4.76

Image of inserts Изображение пластин	Type of cutting Вид обработки	Chipbreaker Стружколом	Description Обозначение	r	Grades Сплавы												
					P115T	P125T	P135T	TC10	M120T	M120GP	M125T	M135T	K120T	N216T	M217T		
	Medium-finishing Получистовая	W+	SCMT 09T304-W+	0.40		●				●	●		●				
			SCMT 09T308-W+	0.80		●	●			●	●		●				
			SCMT 120404-W+	0.40	●	●				●	●						
			SCMT 120408-W+	0.80		●	●			●	●		●				
			SCMT 120412-W+	1.20		●	●				●						
	Medium-finishing Получистовая	FN-MF+	SCGT 09T304-FN-MF+	0.40										●	●		
			SCGT 09T308-FN-MF+	0.80										●	●		
			SCGT 120408-FN-MF+	0.80											●		
					P115T	P125T	P135T	TC10	M120T	M120GP	M125T	M135T	K120T	N216T	M217T		
P Steel - Сталь					★	★	★	★		★	★	☆	☆				
M Stainless steel aust. - Аустенитная нерж. сталь					☆	☆	☆	★	★	★	★	★			★		
K Cast iron - Чугун					★	★		☆	☆				★	★			
N Aluminium - Алюминиевые сплавы									☆					★			
S Hig. temp. alloy - Жаропрочные сплавы							☆				☆				☆		

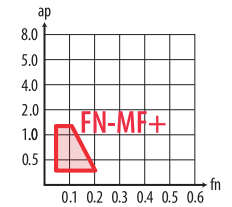
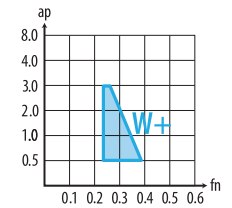

★ Best choice
Наилучшее применение
☆ Second choice
Допустимое применение

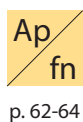
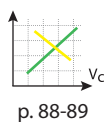

TC... Positive angle

Пластины с положительным задним углом

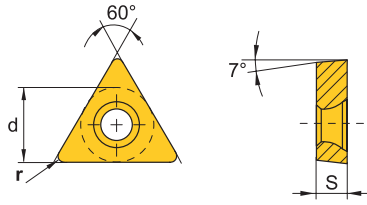

Обозначение	d	s
TC... 090...	5.56	2.38
TC... 110...	6.35	2.38
TC... 16T..	9.52	3.97

Image of inserts Изображение пластин	Type of cutting Вид обработки	Chipbreaker Стружколом	Description Обозначение	r	Grades Сплавы										
					P115T	P125T	P135T	TC10	M120GP	M125T	M135T	K120T	N216T	M217T	
	Medium-finishing Получистовая	UJF	TCGT 110202-UJF	0.20				●							
			TCMT 110204-UJF	0.40				●							
	Medium-finishing Получистовая	WF+	TCMT 110202-WF+	0.20						●					
	Medium-finishing Получистовая	W+	TCMT 090204-W+	0.40		●			●	●		●			
			TCMT 110204-W+	0.40	●	●	●			●	●	●			
			TCMT 110208-W+	0.80		●	●			●	●	●			
			TCMT 16T304-W+	0.40		●	●			●	●	●			
			TCMT 16T308-W+	0.80		●	●			●	●	●			
			TCMT 16T312-W+	1.20		●				●					
	Medium-finishing Получистовая	FN-MF+	TCGT 110204-FN-MF+	0.40									●	●	
			TCGT 16T304-FN-MF+	0.40										●	
			TCGT 16T308-FN-MF+	0.80										●	

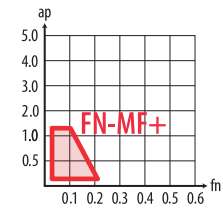
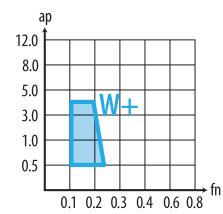
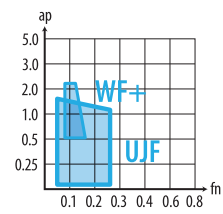

	P115T	P125T	P135T	TC10	M120GP	M125T	M135T	K120T	N216T	M217T
P Steel - Сталь	★	★	★	★	★	★	☆	☆		
M Stainless steel aust. - Аустенитная нерж. сталь	☆	☆	☆	★	★	★	★			☆
K Cast iron- Чугун	★	★		☆				★	★	
N Aluminium - Алюминиевые сплавы				☆					★	
S Hig. temp. alloy - Жаропрочные сплавы			☆			☆				★

★ Best choice
Наилучшее применение

☆ Second choice
Допустимое применение

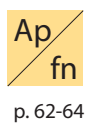
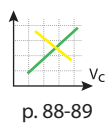

VC... Positive angle

Пластины с положительным задним углом

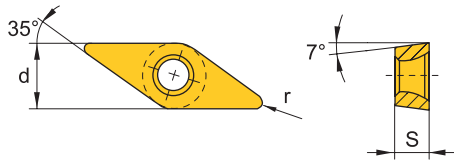

Обозначение	d	s
VC... 110...	6.35	3.18
VC/B... 160...	9.52	4.76

Image of inserts Изображение пластин	Type of cutting Вид обработки	Chipbreaker Стружколом	Description Обозначение	r	Grades Сплавы													
					P115T	P125T	P135T	TC10	M120T	M120GP	M125T	M135T	N216T	M217T				
	Finishing-Medium Чистовая-получистовая	WF+	VCMT 110302-WF+	0.20	●					●	●							
			VCMT 110304-WF+	0.40	●					●	●							
			VCMT 160404-WF+	0.40	●						●	●						
			VCMT 160408-WF+	0.80	●						●							
	Finishing Чистовая	FN-F	VCGT 110300-FN-F	0.05					●									
			VCGT 110301-FN-F	0.10					●									
			VCGT 160400-FN-F	0.05					●									
			VCGT 160401-FN-F	0.10					●									
	Medium-Finishing Получистовая-чистовая	X1+	VBMT 160404-X1+	0.40	●	●												
			VBMT 160408-X1+	0.80		●												
	Medium-finishing Получистовая	W+	VCMT 110304-W+	0.40		●	●				●	●	●					
			VCMT 110308-W+	0.80		●	●				●	●	●					
			VCMT 160404-W+	0.40		●	●					●	●					
			VCMT 160408-W+	0.80		●	●					●	●					
	Medium-finishing Получистовая	FN-MF+	VCGT 110302-FN-MF+	0.20											●	●		
			VCGT 110304-FN-MF+	0.40												●	●	
			VCGT 130302-FN-MF+	0.20												●	●	
			VCGT 130304-FN-MF+	0.40												●	●	
			VCGT 160404-FN-MF+	0.40												●	●	
			VCGT 160408-FN-MF+	0.80												●	●	
			VCGT 160412-FN-MF+	1.20												●	●	
			VCGT 220530-FN-MF+	3.00												●		
					P115T	P125T	P135T	TC10	M120T	M120GP	M125T	M135T	N216T	M217T				
P Steel - Сталь					★	★	★	★	★	★	★	☆						
M Stainless steel aust. - Аустенитная нерж. сталь					☆	☆	☆	★	★	★	★	★			★			
K Cast iron- Чугун					★	★		☆	☆					★				
N Aluminium - Алюминиевые сплавы									☆					★				
S Hig. temp. alloy - Жаропрочные сплавы							☆				☆				☆			

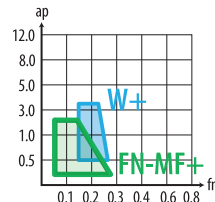
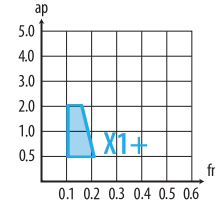
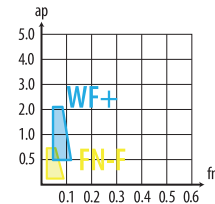

- ★ Best choice
Наилучшее применение
- ☆ Second choice
Допустимое применение

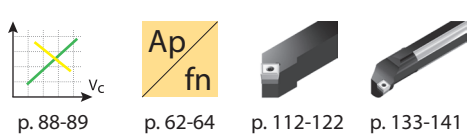

p. 88-89 p. 62-64 p. 112-122 p. 133-141

WC... Positive angle

Пластины с положительным задним углом

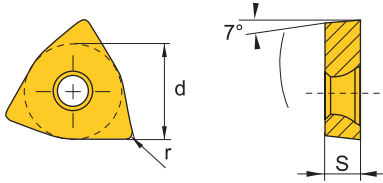

Обозначение	d	s
WC... 020...	3.97	1.59
WC... 040...	6.35	2.38

Обозначение	d	s
WC... 06T...	9.53	3.97
WC... 080...	12.70	4.76

Image of inserts Изображение пластины	Type of cutting Вид обработки	Chipbreaker Стружколом	Description Обозначение	r	Grades Сплавы								
					P115T	P125T	P135T	TC10	M120T	M125T	M135T	K120T	
	Finishing Чистовая	UJF	WCGT 020102-UJF	0.20				●					
	Medium-finishing Получистовая	W+	WCMT 040204-W+	0.40		●				●			
			WCMT 040208-W+	0.80		●				●			
			WCMT 06T304-W+	0.40		●				●			
			WCMT 06T308-W+	0.80		●				●			
			WCMT 080404-W+	0.40		●				●			
			WCMT 080408-W+	0.80		●				●			
			WCMT 080412-W+	1.20		●				●			

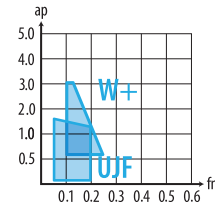

	P115T	P125T	P135T	TC10	M120T	M125T	M135T	K120T
P Steel - Сталь	★	★	★	★	★	★	☆	☆
M Stainless steel aust. - Аустенитная нерж. сталь	☆	☆	☆	★	★	★	★	
K Cast iron - Чугун	★	★	★	☆	☆	☆	☆	★
N Aluminium - Алюминиевые сплавы					☆			
S Hig. temp. alloy - Жаропрочные сплавы			☆			☆		

- ★ Best choice
Наилучшее применение
- ☆ Second choice
Допустимое применение

RC... Positive angle

Пластины с положительным задним углом

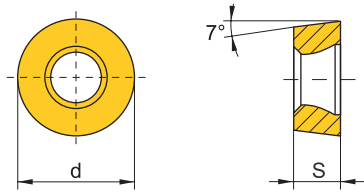

Обозначение	d	s
RC... 080...	8.00	3.18
RC... 100...	10.0	4.40
RC... 120...	12.0	4.76

Обозначение	d	s
RC... 160...	16.0	6.35
RC... 200...	20.0	6.35

Grades
Сплавы

Image of inserts Изображение пластин	Type of cutting Вид обработки	Chipbreaker Стружколом	Description Обозначение	r	P115T	P125T	P135T	TC10	M120T	N216T	M217T	S115T
	Medium-finishing Получистовая	W+	RCMT 0803MO-W+				●					
			RCMT 1003MO-W+				●					
			RCMT 1204MO-W+					●				
	Roughing Черновая	SN-R	RCMT 1606-SN-R			●	●					
			RCMT 2006-SN-R			●	●					
					P115T	P125T	P135T	TC10	M120T	N216T	M217T	S115T
P Steel - Сталь						★	★					
M Stainless steel aust. - Аустенитная нерж. сталь						☆	☆					
K Cast iron - Чугун						★						
N Aluminium - Алюминиевые сплавы												
S Hig. temp. alloy - Жаропрочные сплавы							☆					

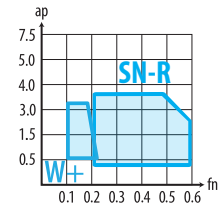

- ★ Best choice
Наилучшее применение
- ☆ Second choice
Допустимое применение

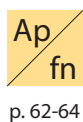
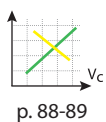

A series of horizontal dotted lines for writing, spanning the width of the page.

	Обрабатываемый материал	Твердость НВ	Скорость резания для сплавов Vc (м/мин)						
			P115T	P125T	P125GP	P135T	TC10	M120T	M125T
P	Нелегированная сталь	125	255-500	190-290	190-290	190-230	280-350		125-280
		150-250	220-400	165-240	160-270	170-190	225-270		135-255
		300	175-300	125-200	125-210	125-150	190-110		100-180
	Низколегированная сталь	180	155-400	165-250	165-250	165-190	255-300		130-200
		250-300	200-320	100-190	100-210	90-150	180-230		60-175
		350	150-280	80-170	90-190	70-130	140-220		50-155
	Высоколегированная сталь	200	175-320	125-210	125-210	125-200	165-200		75-200
		350	125-280	80-160	130-230	50-100	165-200		40-140
Сталь, устойчивая к коррозии	200	200-320	125-220	130-230	140-180	230-270		100-200	
	350	150-280	110-190	130-210	110-160	170-250		75-150	
M	Нержавеющая сталь	200	220-300	135-210	140-210	135-200	165-200	150-200	125-250
		180		100-210	100-210	110-190	200-245	125-200	100-220
		230-260				80-150		90-155	55-160
		330		75-100	75-100	50-75	125-160	55-80	40-100
K	Серый чугун	180	135-370	125-210				120-155	
		260	135-330	125-200				90-130	
	Чугун с шаровидным графитом	160	190-430	120-240			225-300		
		-	140-270	120-240			180-250		
	Закаленный чугун	130	175-520	155-250			255-350		
230		145-330	125-200			265-250			
N	Алюминиевые ковкие сплавы	60							
		100							
	Алюминиевые литейные сплавы	80							
		90							
		130							
	Медь и медные сплавы (бронза, латунь)	-							
		-							
		90							
100									
Неметаллы	100								
	-								
	-								
S	Жаропрочные сплавы	200						25-50	
		280						25-50	
		250						15-45	
		-						20-35	
		-						10-25	
	Титановые сплавы	Rm 440*						75-140	
		Rm 1050*						25-45	

*Rm - предел прочности, МПа

								Обрабатываемый материал		
M120GP	M135T	K110GP	K120T	N216T	M217T	S110T	S115T			
125-280	175-230	250-500	225-450					Нелегированная сталь	P	
135-260	165-190	220-400	200-350							
100-180	125-150	170-340	165-270							
130-200	165-190	200-400	200-365							Низколегированная сталь
60-175	90-150	170-340	150-290							
50-155	70-130	150-300	125-260							
75-200	125-200	170-340	150-290							Высоколегированная сталь
40-140	50-100	125-260	100-260							
100-200	140-180	170-300	165-290							Сталь, устойчивая к коррозии
75-150	110-160	150-270	130-250							
125-280	135-200				120-180	150-225	125-220	Нержавеющая сталь	M	
100-240	110-190				120-180	135-190	120-175			
55-160	80-155				80-145	60-100	50-90			
40-100	50-75				50-70					
		170-450	145-400					Серый чугун	K	
		145-400	175-350							
		220-450	200-450					Чугун с шаровидным графитом		
			155-300							
		220-550	200-550					Закаленный чугун		
		155-400	155-350							
				300-2500				Алюминиевые ковкие сплавы	N	
				200-2000						
				400-1500				Алюминиевые литейные сплавы		
				400-1500						
				200-800						
				250-600				Медь и медные сплавы (бронза, латунь)		
				200-600						
				150-400						
				150-300						
				80-180				Неметаллы		
				60-150						
				100-250						
					30-45	80-120	80-120	Жаропрочные сплавы	S	
					20-35	55-100	55-100			
					20-35	30-90	30-90			
					18-30	30-50	30-50			
						30-45	30-45			
					60-120	65-120	65-120	Титановые сплавы		
						40-75	40-75			

*Rm - предел прочности, МПа

Blank page with horizontal dotted lines for writing.

5

TOOLS WITH CARBIDE INSERTS
ИНСТРУМЕНТ СО СМЕННЫМИ ТВЕРДОСПЛАВНЫМИ ПЛАСТИНАМИ

EXTERNAL TOOLHOLDERS
ТОКАРНЫЕ ДЕРЖАВКИ ДЛЯ
НАРУЖНОЙ ОБРАБОТКИ

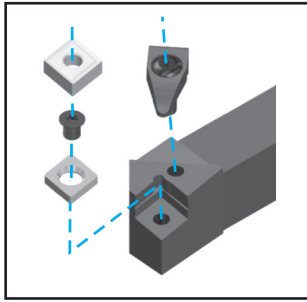

«D» Dimple lock

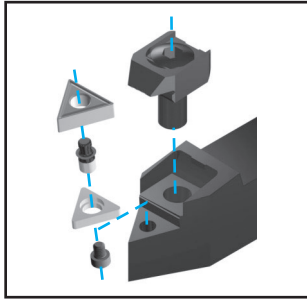
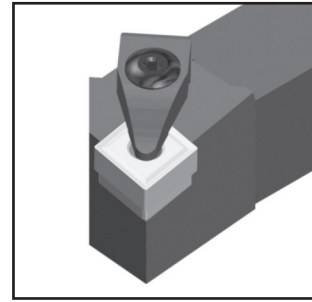

«M» Wedge clamp

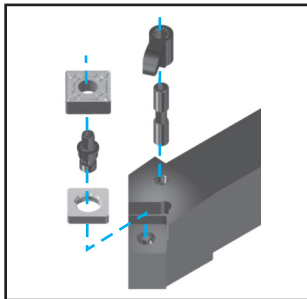
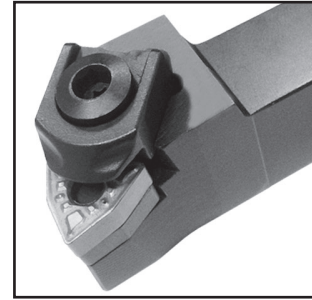

«M-K» Double lock

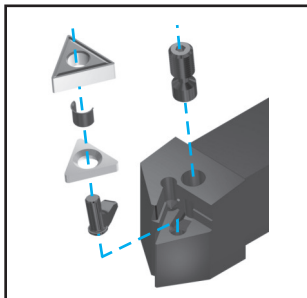
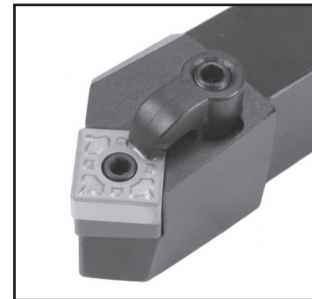

«P» Lever lock

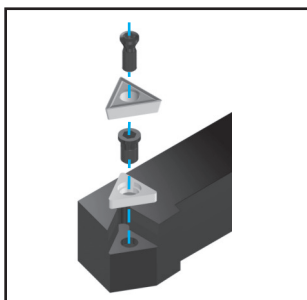
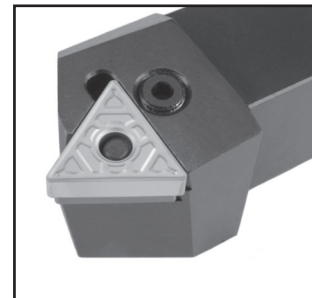

«S» Screw lock

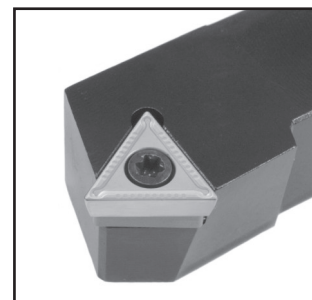

P	C	L	N	R	25	25	M	12
1	2	3	4	5	6	7	8	9

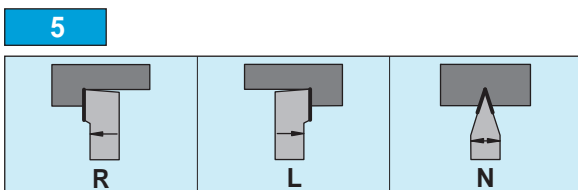
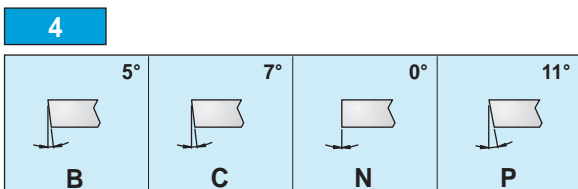
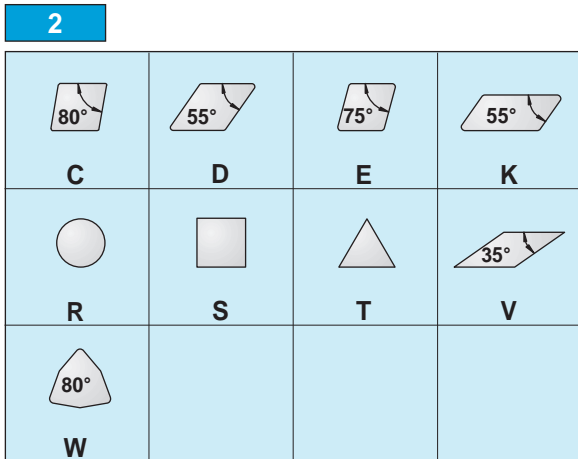
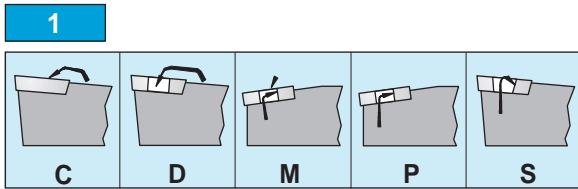

8



D	60	P	170
E	70	R	200
F	80	S	250
H	100	T	300
K	125	U	350
L	140	V	400
M	150	X	Special

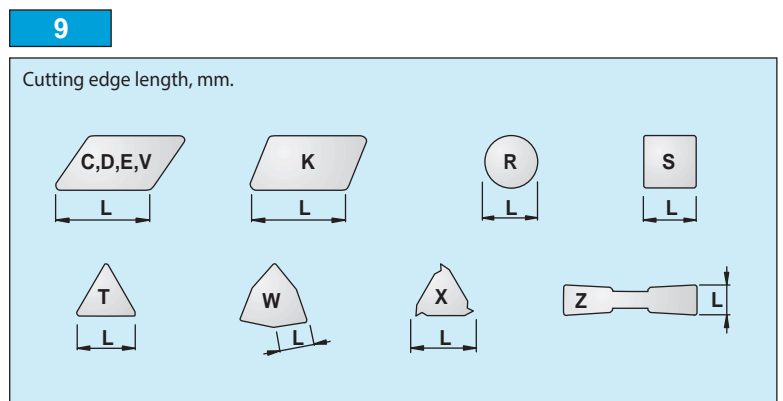
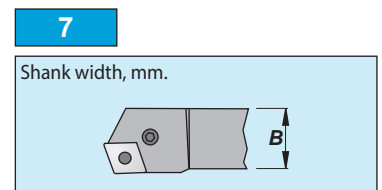
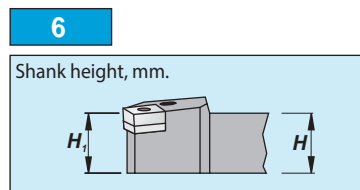
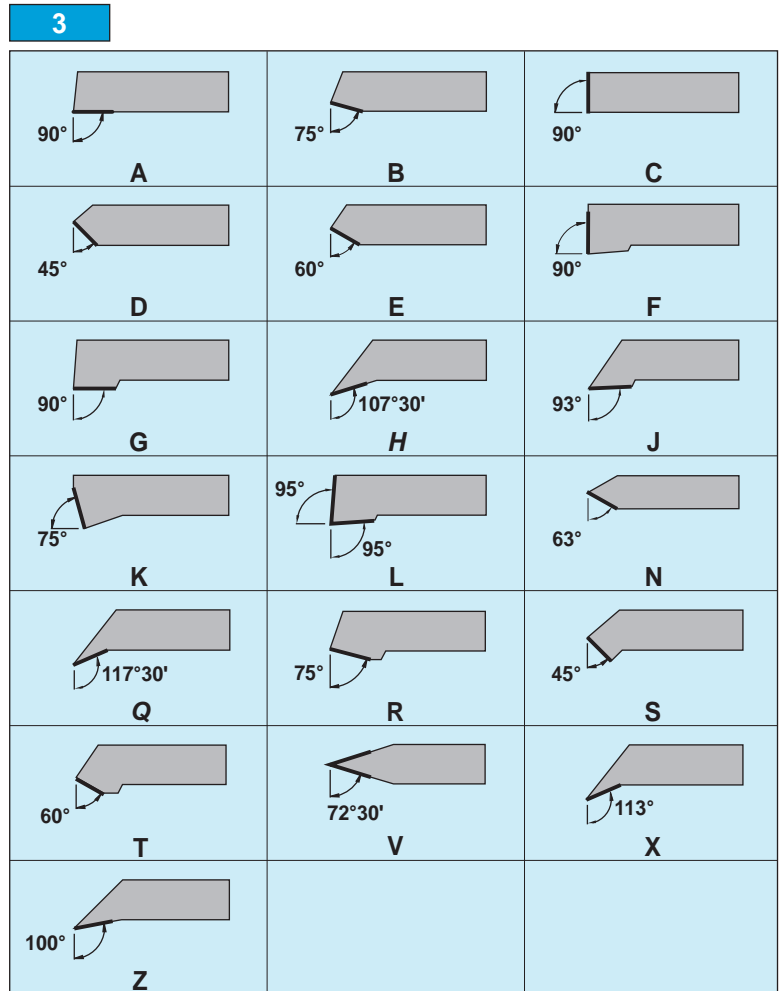

Top clamp

CKJN 93°

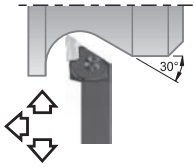

Page 97 KNUX 1604..

CKNN 63°

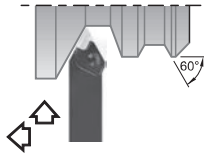

Page 97 KNUX 1604..

Dimple lock

DCLN 95°-N

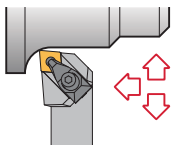

Page 98 CN.. 1204..
CN.. 1906..

DDJN 93°-N

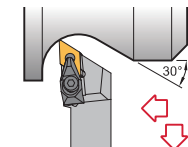

Page 98 DN.. 1104..
DN.. 1506..

DSSN 45°-N

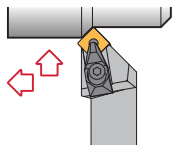

Page 99 SNM.. 1204..
SNM.. 1906..

DTGN 90°-N

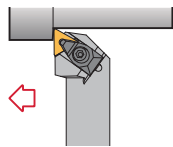

Page 99 TNM.. 1604..
TNM.. 2204..

DVJN 93°-N

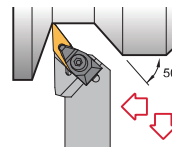

Page 100 VN.. 1604..

DWLN 95°-N

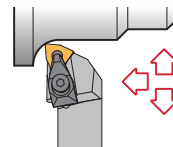

Page 100 WNMG 0804..

Lever lock

PCBN 75°

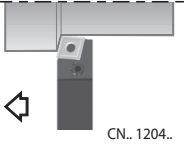

Page 102 CN.. 1204..
CN.. 1606..
CN.. 1906..

PCKN 75°

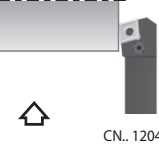

Page 102 CN.. 1204..
CN.. 1906..
CN.. 2509..

PCLN 95°

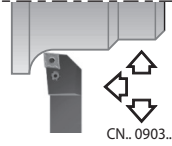

Page 103 CN.. 0903..
... CN.. 2509..

PCMN 50°

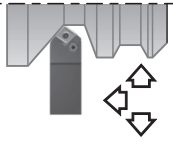

Page 103 CN.. 1204..
CN.. 1906..

PCSN 45°

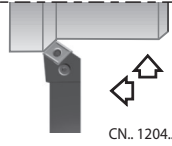

Page 104 CN.. 1204..
CN.. 1606..
CN.. 1906..

PDJN 93°

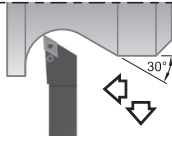

Page 104 DN.. 1104..
DN.. 1506..

PDNN 63°



Page 105 DN.. 1506..

PRDC

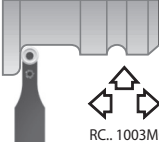

Page 105 RC.. 1003M0
... RC.. 3209M0

PRSC / PRSN

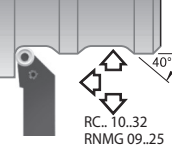

Page 106 RC.. 10..32
RNMG 09..25

PSBN 75°

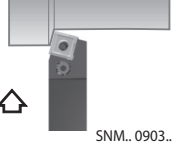

Page 107 SNM.. 0903..
... SNM.. 2507..

PSDN 45°

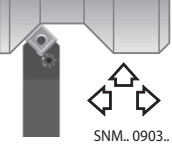

Page 107 SNM.. 0903..
... SNM 2507..

PSKN 75°

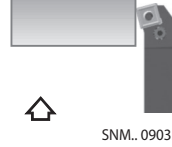

Page 108 SNM.. 0903..
... SNM.. 2507..

PSSN 45°

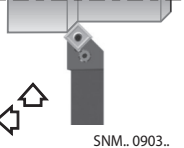

Page 108 SNM.. 0903..
... SNM.. 2507..

PTDN 45°

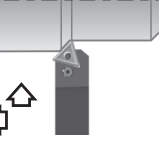

Page 109 TNM.. 2204..

PTFN 90°

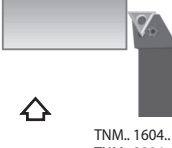

Page 109 TNM.. 1604..
TNM.. 2204..
TNM.. 2706..

PTGN 90°

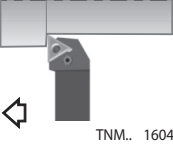

Page 110 TNM.. 1604..
... TNM.. 3307..

PTTN 60°

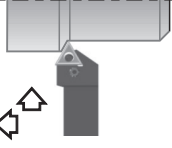

Page 110 TNM.. 1604..
TNM.. 2204..

PWLN 95°

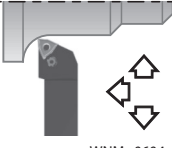

Page 111 WNM.. 0604..
WNM.. 0804..

Screw lock

<p>SCAC 90°</p> <p>CC.. 0602.. CC.. 09T3.. CC.. 1204..</p> <p>Page 112</p>	<p>SCLC 95°</p> <p>CC.. 0602.. CC.. 09T3.. CC.. 1204..</p> <p>Page 112</p>	<p>SDJC 93°</p> <p>DC.. 0702.. DC.. 11T3..</p> <p>Page 113</p>	<p>SDNC 62°30'</p> <p>DC.. 0702.. DC.. 11T3..</p> <p>Page 113</p>	<p>SRDC</p> <p>RC.. 0602M0 RC.. 0803M0 RC.. 10T3M0 RC.. 1204M0</p> <p>Page 114</p>	<p>SSBC 75°</p> <p>SC.. 09T3.. SC.. 1204..</p> <p>Page 114</p>
<p>SSDC 45°</p> <p>SC.. 09T3.. SC.. 1204..</p> <p>Page 115</p>	<p>SSSC 45°</p> <p>SC.. 09T3.. SC.. 1204..</p> <p>Page 115</p>	<p>STAC 90°</p> <p>TC.. 0902.. TC.. 1102.. TC.. 16T3..</p> <p>Page 116</p>	<p>STDC 45°</p> <p>TC.. 0902.. TC.. 1102.. TC.. 16T3..</p> <p>Page 116</p>	<p>STFC 90°</p> <p>TC.. 0902.. TC.. 1102.. TC.. 16T3..</p> <p>Page 117</p>	<p>STGC 90°</p> <p>TC.. 0902.. TC.. 1102.. TC.. 16T3..</p> <p>Page 117</p>
<p>STJC 93°</p> <p>TC.. 0902.. TC.. 1102.. TC.. 16T3..</p> <p>Page 118</p>	<p>STTC 60°</p> <p>TC.. 0902.. TC.. 1102.. TC.. 16T3..</p> <p>Page 118</p>	<p>SVHC 107°30'</p> <p>VC.. 1604..</p> <p>Page 119</p>	<p>SVJB 93°</p> <p>VBMT 1604..</p> <p>Page 119</p>	<p>SVJC 93°</p> <p>VC.. 1103.. VC.. 1604..</p> <p>Page 120</p>	<p>SVLC 95°</p> <p>VCMT 1303..</p> <p>Page 120</p>
<p>SVVB 72°30'</p> <p>VBMT 1604..</p> <p>Page 121</p>	<p>SVVC 72°30'</p> <p>VC.. 1103.. VC.. 1604..</p> <p>Page 121</p>	<p>SVXC 113°</p> <p>VCMT 1303..</p> <p>Page 122</p>	<p>SVZC 100°</p> <p>VC.. 1604..</p> <p>Page 122</p>		

Toolholders with wedge and double clamping (on request) / Державки с двойным прижимом

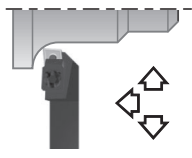
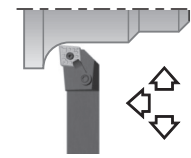
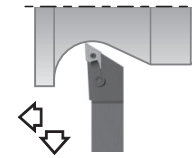
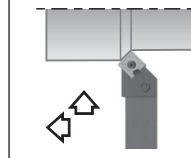
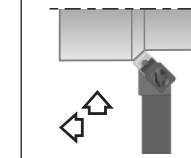
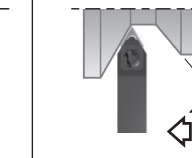
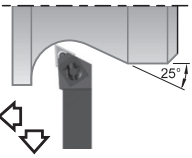
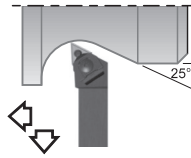
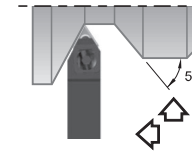
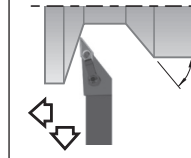
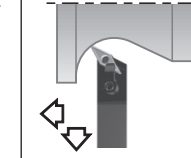
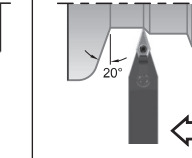
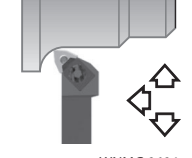
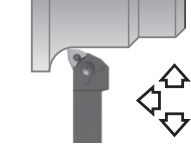
<p>MCLN 95°</p>  <p>CN.. 1204.. CN.. 1906..</p>	<p>MCLN-K 95°</p>  <p>CN.. 1204.. CN.. 1906..</p>	<p>MDJN-K 93°</p>  <p>DN.. 1506..</p>	<p>MSSN-K 45°</p>  <p>SNM.. 1204..</p>	<p>MSSN 45°</p>  <p>SNM.. 1204.. SNM.. 1906..</p>	<p>MTEN 60°</p>  <p>TNM.. 1604.. TNM.. 2204..</p>
<p>MTJN 93°</p>  <p>TNM.. 1604.. TNM.. 2204..</p>	<p>MTJN-K 93°</p>  <p>TNM.. 1604.. TNM.. 2204..</p>	<p>MTNN 63°</p>  <p>TNM.. 1604.. TNM.. 2204..</p>	<p>MVJN-K 93°</p>  <p>VN.. 1604..</p>	<p>MVQN-K 117° 30'</p>  <p>VN.. 1604..</p>	<p>MVVN-K 72° 30'</p>  <p>VN.. 1604..</p>
<p>MWLN 95°</p>  <p>WNMG 0604.. WNMG 0804..</p>	<p>MWLN-K 95°</p>  <p>WNM.. 0804..</p>				

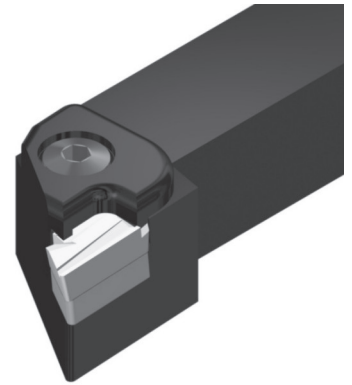
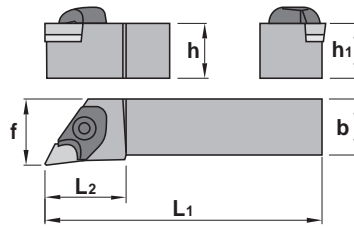
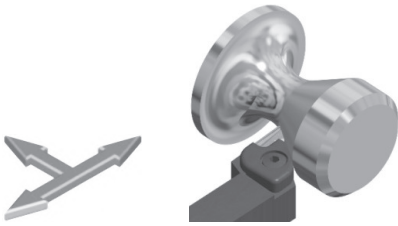

General angle 93°
Главный угол в плане 93°

CKJN

	h=h ₁	b	L ₁	L ₂	f	Plates										
CKJN R/L 2020 K16	20	20	125	34	30	KNUX 1604..	0,390	2316	2326	1614	5004	4295	4203	3226	3236	4012
CKJN R/L 2525 M16	25	25	150	34	32	KNUX 1604..	0,700	2316	2326	1614	5004	4295	4204	3226	3236	4012
CKJN R/L 3225 P16	32	25	170	34	32	KNUX 1604..	1,000	2316	2326	1614	5004	4295	4204	3226	3236	4012
CKJN R/L 3232 P16	32	32	170	34	40	KNUX 1604..	1,250	2316	2326	1614	5004	4295	4204	3226	3236	4012
CKJN R/L 4025 R16	40	25	200	38	32	KNUX 1604..	1,500	2316	2326	1614	5004	4295	4204	3226	3236	4012

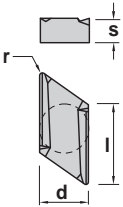

KNUX	l	s	d	KNUX
KNUX 1604..	16,00	4,76	9,52	

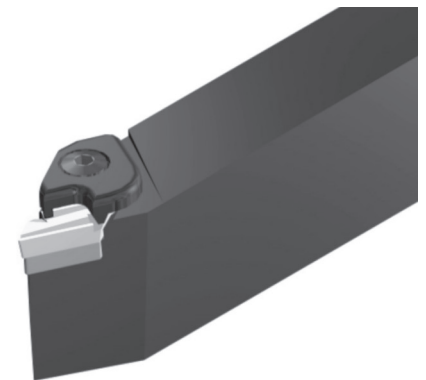
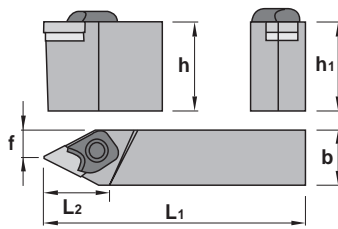
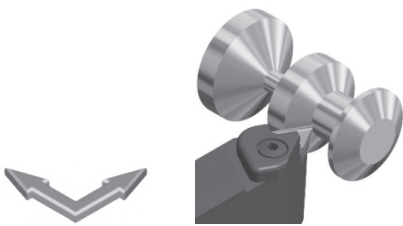

General angle 63°
Главный угол в плане 63°

CKNN

	h=h ₁	b	L ₁	L ₂	f	Plates										
CKNN R/L 4025 R16	40	25	200	37	14,3	KNUX 1604..	1,500	2316	2326	1614	5004	4295	4204	3226	3236	4012
CKNN R/L 5032 S16	50	32	250	37	16,8	KNUX 1604..	3,000	2316	2326	1614	5004	4295	4204	3226	3236	4012

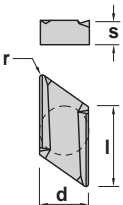

KNUX	l	s	d	KNUX
KNUX 1604..	16,00	4,76	9,52	

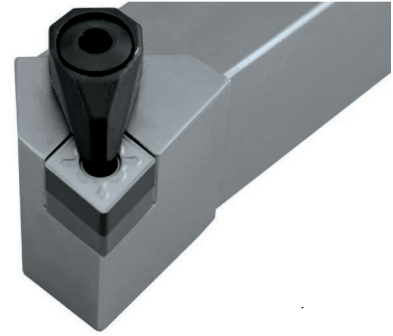
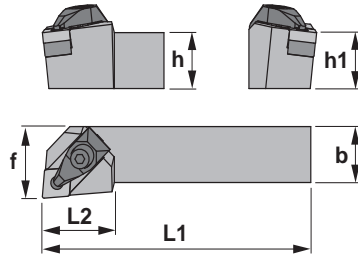
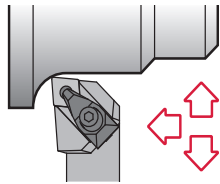

General angle 95°
Главный угол в плане 95°

DCLN 95°

	h=h1	b	L1	L2	f	Plates							
DCLN R/L 2020 K12-N	20	20	125	34	25	CN.. 1204..	0,400	ICSN-442	1766	2712	1696	4295	5004
DCLN R/L 2525 M12-N	25	25	150	34	32	CN.. 1204..	0,750	ICSN-442	1766	2712	1696	4295	5004
DCLN R/L 3232 P12-N	32	32	170	34	40	CN.. 1204..	1,300	ICSN-442	1766	2712	1696	4295	5004
DCLN R/L 2525 M16-N	25	25	150	42	32	CN.. 1606..	0,750	ICSN-533	1768	2716	1696	4295	5004
DCLN R/L 3232 P16-N	32	32	170	42	40	CN.. 1606..	1,300	ICSN-533	1768	2716	1696	4295	5004
DCLN R/L 3232 P19-N	32	32	170	42	40	CN.. 1906..	1,300	ICSN-633	1770	2719	1696	4295	5004
DCLN R/L 4040 S19-N	40	40	250	45	50	CN.. 1906..	3,050	ICSN-633	1770	2719	1696	4295	5004

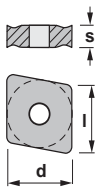

CN..	l	s	d	CNMG	CNMA	CNMM
CN.. 1204..	12,90	4,76	12,70			
CN.. 1606..	16,10	6,35	15,88			
CN.. 1906..	19,30	6,35	19,05			

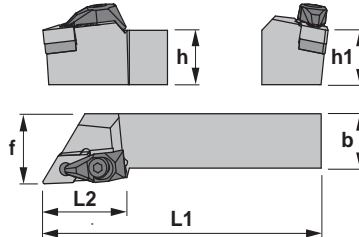
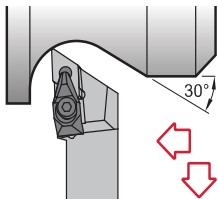

General angle 93°
Главный угол в плане 93°

DDJN 93°

	h=h1	b	L1	L2	f	Plates							
DDJN R/L 2020 K11-N	20	20	125	34	25	DN.. 1104..	0,400	IDSN-322	1764	2708	1695	4294	5004
DDJN R/L 2525 M11-N	25	25	150	34	32	DN.. 1104..	0,740	IDSN-322	1764	2708	1695	4294	5004
DDJN R/L 2020 K15-N	20	20	125	42	25	DN.. 1506..	0,400	IDSN-432	1766	2712	1696	4295	5004
DDJN R/L 2525 M15-N	25	25	150	42	32	DN.. 1506..	0,750	IDSN-432	1766	2712	1696	4295	5004
DDJN R/L 3232 P15-N	32	32	170	42	40	DN.. 1506..	1,300	IDSN-432	1766	2712	1696	4295	5004

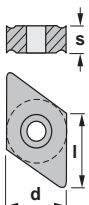

DN..	l	s	d	DNMA	DNMG	DNMM
DN.. 1104..	11,60	4,76	9,52			
DN.. 1506..	15,50	6,35	12,70			

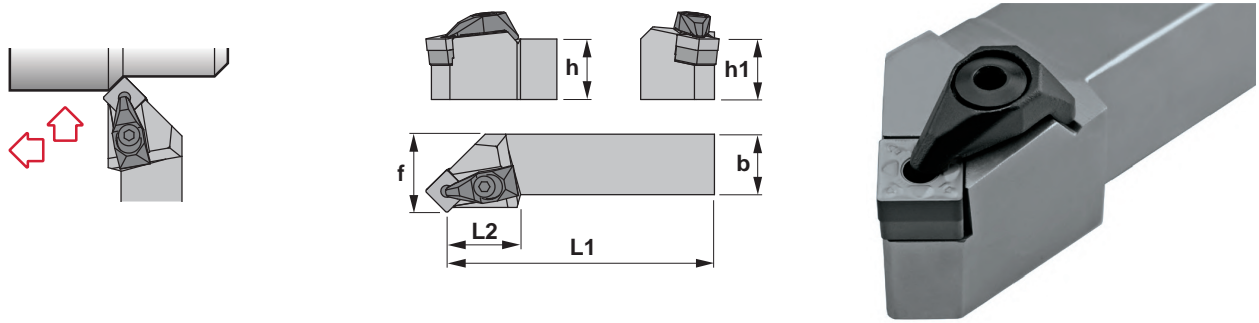

General angle 45°
Главный угол в плане 45°

DSSN 45°

	h=h1	b	L1	L2	f	Plates							
DSSNR/L2020 K12-N	20	20	125	28	25	SNM.. 1204..	0,400	ISSN-442	1766	2712	1696	4295	5004
DSSNR/L2525 M12-N	25	25	150	28	32	SNM.. 1204..	0,750	ISSN-442	1766	2712	1696	4295	5004
DSSNR/L3225 P12-N	32	25	170	42	32	SNM.. 1204..	1,140	ISSN-442	1766	2712	1696	4295	5004
DSSNR/L2525 M15-N	25	25	150	42	32	SNM.. 1506..	0,820	ISSN-533	1768	2716	1696	4295	5004
DSSNR/L3232 P15-N	32	32	170	45	40	SNM.. 1506..	1,440	ISSN-533	1768	2716	1696	4295	5004
DSSNR/L3232 P19-N	32	32	170	45	40	SNM.. 1906..	1,300	ISSN-633	1770	2719	1696	4295	5004
DSSNR/L4040 S19-N	40	40	250	45	50	SNM.. 1906..	3,100	ISSN-633	1770	2719	1696	4295	5004

	SNM	l	s	d	SNMG-MHC	SNMM
	SNM.. 1204..	12,70	4,76	12,70		
	SNM.. 1506..	15,88	6,35	15,88		
	SNM.. 1906..	19,05	6,35	19,05		

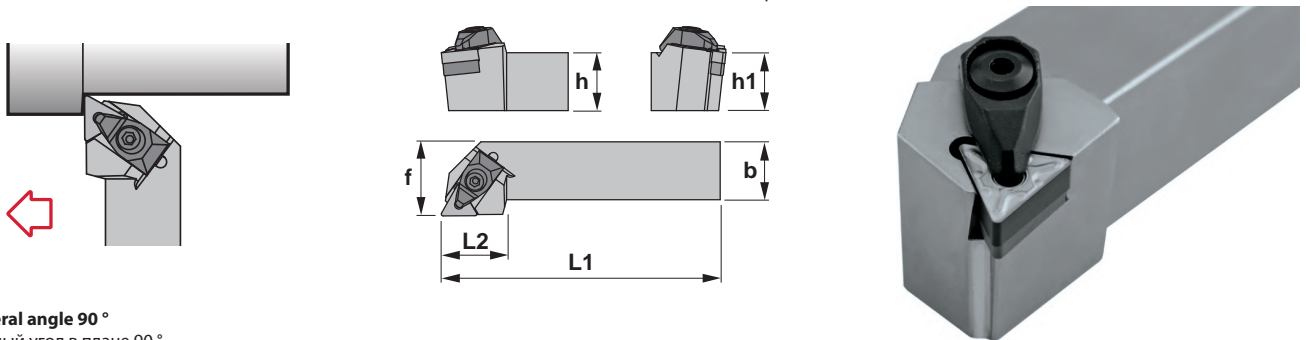

General angle 90°
Главный угол в плане 90°

DTGN 90°

	h=h1	b	L1	L2	f	Plates							
DTGN R/L 2020 K16-N	20	20	125	28	25	TNM.. 1604..	0,400	ITSN-342	1764	2708	1695	4294	5004
DTGN R/L 2525 M16-N	25	25	150	28	32	TNM.. 1604..	0,750	ITSN-342	1764	2708	1695	4294	5004
DTGN R/L 2525 M22-N	25	25	150	34	32	TNM.. 2204..	0,750	ITSN-433	1766	2712	1696	4295	5004
DTGN R/L 3232 P22-N	32	32	170	34	40	TNM.. 2204..	1,300	ITSN-433	1766	2712	1696	4295	5004

	TNM	l	s	d	TNMA	TNMG
	TNM.. 1604..	16,50	4,76	9,52		
	TNM.. 2204..	22,00	4,76	12,70		

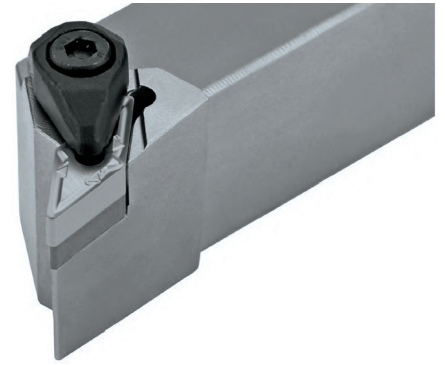
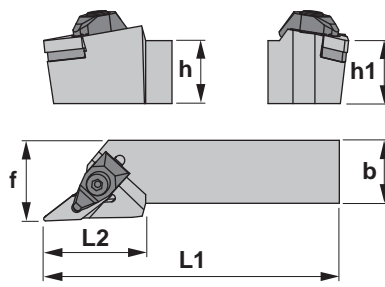
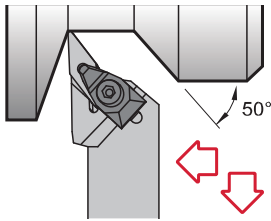

General angle 93°
Главный угол в плане 93°

DVJN 93°

	h=h1	b	L1	L2	f	Plates	kg						
DVJN R/L 2020 K16-N	20	20	125	34	25	VN.. 1604..	0,400	IVSN-322	1764	2708	1695	4294	5004
DVJN R/L 2525 M16-N	25	25	150	34	32	VN.. 1604..	0,700	IVSN-322	1764	2708	1695	4294	5004
DVJN R/L 3225 P16-N	32	25	170	34	32	VN.. 1604..	1,040	IVSN-322	1764	2708	1695	4294	5004
DVJN R/L 3232 P16-N	32	32	170	34	40	VN.. 1604..	1,250	IVSN-322	1764	2708	1695	4294	5004

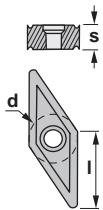

VN...	l	s	d	VNGP	VNMG
VN.. 1604..	16,50	4,76	9,52		

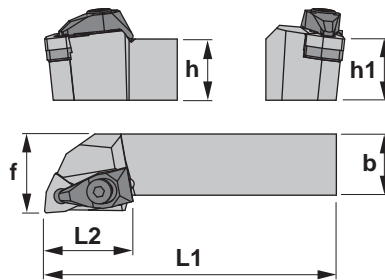
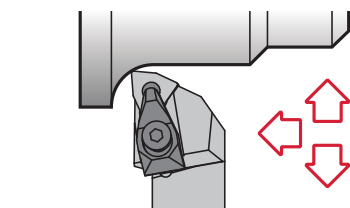

General angle 95°
Главный угол в плане 95°

DWLN 95°

	h=h1	b	L1	L2	f	Plates	kg						
DWLN R/L 2020 K06-N	20	20	125	34	25	WNMG 0604..	0,400	IWSN-322	1764	2708	1695	4294	5004
DWLN R/L 2525 M06-N	25	25	150	34	32	WNMG 0604..	0,700	IWSN-322	1764	2708	1695	4294	5004
DWLN R/L 2020 K08-N	20	20	125	34	25	WNMG 0804..	0,400	IWSN-433	1766	2712	1696	4295	5004
DWLN R/L 2525 M08-N	25	25	150	34	32	WNMG 0804..	0,750	IWSN-433	1766	2712	1696	4295	5004
DWLN R/L 3232 P08-N	32	32	170	34	40	WNMG 0804..	1,300	IWSN-433	1766	2712	1696	4295	5004

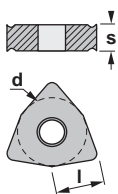

WN...	l	s	d	WNMG
WNMG 0604..	6,45	4,76	9,52	
WNMG 0804..	8,14	4,76	12,70	

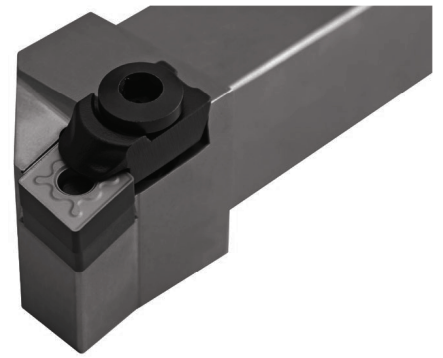
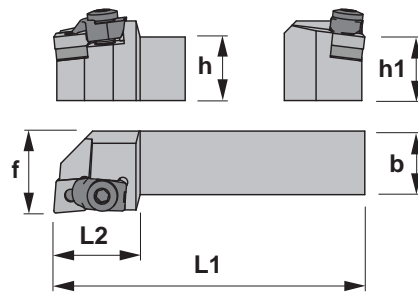
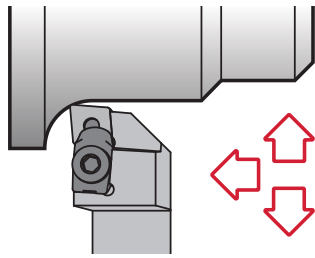

General angle 95°

Главный угол в плане 95°

MCLN

	h=h1	b	L1	L2	f	Plates						
MCLN R/L 2020 K12	20	20	125	34	25	CN...12...	0,450	2015	5005	ICSN-432	1661	1394
MCLN R/L 2525 M12	25	25	150	34	32	CN...12...	0,800	2015	5005	ICSN-432	1661	1394
MCLN R/L 3225 P12	32	25	170	34	32	CN...12...	1,200	2015	5005	ICSN-432	1661	1394
MCLN R/L 2525 M19	25	25	150	42	32	CN...19...	0,800	2024	5005	3619	1682	1296
MCLN R/L 3225 P19	32	25	170	42	32	CN...19...	1,200	2024	5005	3619	1682	1296
MCLN R/L 4040 S19	40	40	250	45	50	CN...19...	3,100	2024	5005	3619	1682	1296

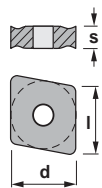

CN...	l	s	d	CNMG	CNMA	CNMM
CN.. 1204..	12,90	4,76	12,70			
CN.. 1606..	16,10	6,35	15,88			
CN.. 1906..	19,30	6,35	19,05			

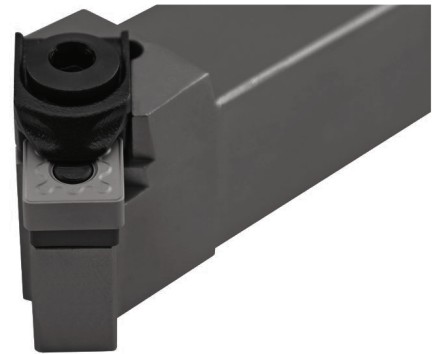
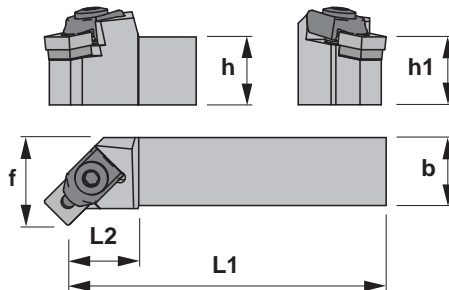
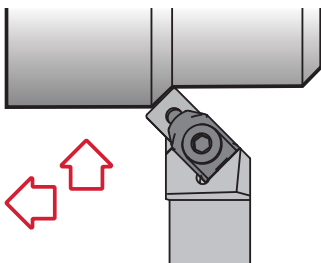

General angle 45°

Главный угол в плане 45°

MSSN

	h=h1	b	L1	L2	f	Plates						
MSSN R/L 2020 K12	20	20	125	34	27	SN...12...	0,450	2014	5005	3514	1661	1394
MSSN R/L 2525 M12	25	25	150	34	32	SN...12...	0,800	2014	5005	3514	1661	1394
MSSN R/L 3225 P12	32	25	170	34	32	SN...12...	1,200	2014	5005	3514	1661	1394
MSSN R/L 2525 M19	25	25	150	42	32	SN...19...	0,800	2024	5005	3519	1682	1296
MSSN R/L 3225 P19	32	25	170	42	32	SN...19...	1,200	2024	5005	3519	1682	1296
MSSN R/L 3232 P19	32	32	170	42	40	SN...19...	1,400	2024	5005	3519	1682	1296
MSSN R/L 4040 S19	40	40	250	42	50	SN...19...	3,100	2024	5005	3519	1682	1296

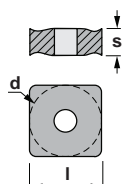

SN...	l	s	d	SNMG-MHC	SNMM
SNM.. 1204..	12,70	4,76	12,70		
SNM.. 1506..	15,88	6,35	15,88		
SNM.. 1906..	19,05	6,35	19,05		

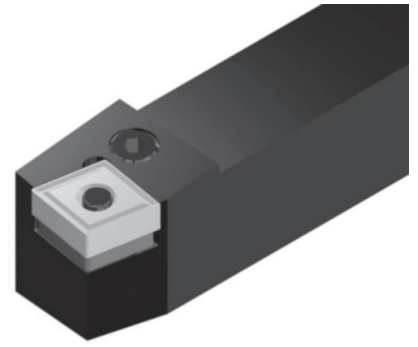
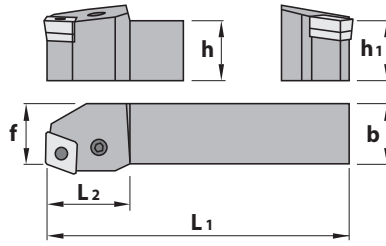
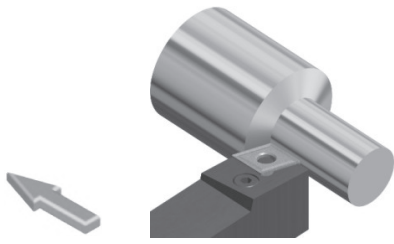

General angle 75°
Главный угол в плане 75°

PCBN

	h=h ₁	b	L ₁	L ₂	f	Plates							
PCBN R/L 2020 K12	20	20	125	28	17	CN.. 1204..	0,400	8012	1608	5003	3612	4112	0012
PCBN R/L 2525 M12	25	25	150	28	22	CN.. 1204..	0,750	8012	1608	5003	3612	4112	0012
PCBN R/L 2525 M16	25	25	150	34	22	CN.. 1606..	0,750	8016	1618	5003	3616	4115	0015
PCBN R/L 3225 P16	32	25	170	34	22	CN.. 1606..	1,050	8016	1618	5003	3616	4115	0015
PCBN R/L 3232 P16	32	32	170	34	27	CN.. 1606..	1,300	8016	1618	5003	3616	4115	0015
PCBN R/L 3225 P19	32	25	170	38	22	CN.. 1906..	1,050	8019	1610	5004	3619	4119	0019
PCBN R/L 3232 P19	32	32	170	42	27	CN.. 1906..	1,300	8019	1610	5004	3619	4119	0019
PCBN R/L 4040 S19	40	40	250	48	35	CN.. 1906..	3,050	8019	1610	5004	3619	4119	0019
PCBN R/L 4040 S25	40	40	250	48	41	CN.. 2509..	-	8025	1612	5005	3625	4125	0025
PCBN R/L 5050 T25	50	50	300	50	51	CN.. 2509..	-	8025	1612	5005	3625	4125	0025

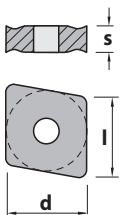

CN..	l	s	d	CNGP	CNMA	CNMG	CNMM
CN.. 1204..	12,90	4,76	12,70				
CN.. 1606..	16,10	6,35	15,88				
CN.. 1906..	19,30	6,35	19,05				
CN.. 2509..	25,80	9,52	25,40				

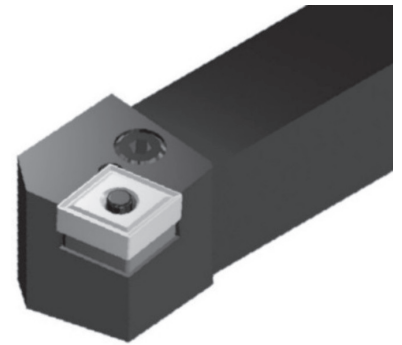
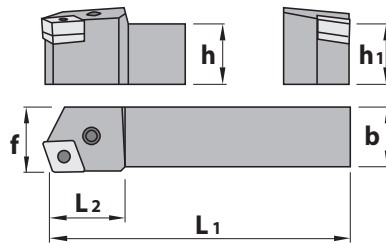
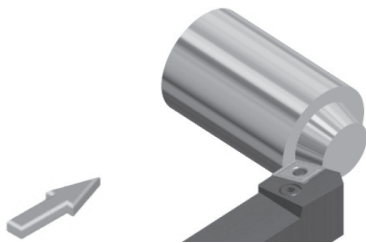

General angle 75°
Главный угол в плане 75°

PCKN

	h=h ₁	b	L ₁	L ₂	f	Plates							
PCKN R/L 2020 K12	20	20	125	28	25	CN.. 1204..	0,400	8012	1608	5003	3612	4112	0012
PCKN R/L 2525 M12	25	25	150	28	32	CN.. 1204..	0,750	8012	1608	5003	3612	4112	0012
PCKN R/L 3225 P12	32	25	170	28	32	CN.. 1204..	1,050	8012	1608	5003	3612	4112	0012
PCKN R/L 3232 P19	32	32	170	42	40	CN.. 1906..	1,300	8019	1610	5004	3619	4119	0019
PCKN R/L 4040 S19	40	40	250	45	50	CN.. 1906..	3,050	8019	1610	5004	3619	4119	0019
PCKN R/L 4040 S25	40	40	250	45	50	CN.. 2509..	3,050	8025	1612	5005	3625	4125	0025
PCKN R/L 5050 T25	50	50	300	50	60	CN.. 2509..	5,850	8025	1612	5005	3625	4125	0025

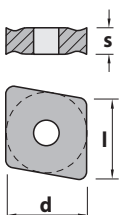

CN..	l	s	d	CNGP	CNMA	CNMG	CNMM
CN.. 1204..	12,90	4,76	12,70				
CN.. 1906..	19,30	6,35	19,05				
CN.. 2509..	25,80	9,52	25,40				

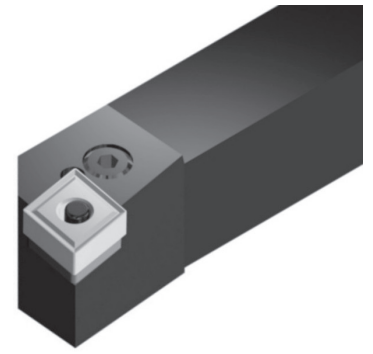
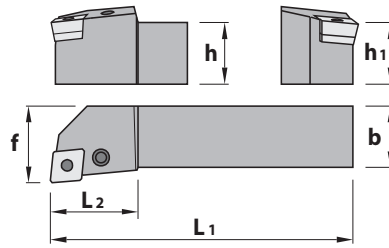
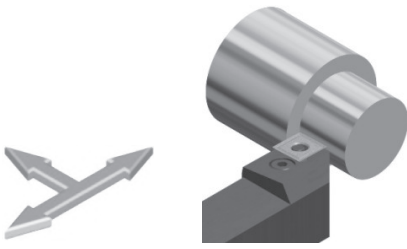

General angle 95°
Главный угол в плане 95°

PCLN

	h=h ₁	b	L ₁	L ₂	f	Plates							
PCLN R/L 1616 H09	16	16	100	25	20	CN.. 0903..	0,250	8009	1606	5025	3609	4109	0009
PCLN R/L 2020 K09	20	20	125	28	25	CN.. 0903..	0,400	8009	1606	5025	3609	4109	0009
PCLN R/L 2525 M09	25	25	150	28	32	CN.. 0903..	0,750	8009	1606	5025	3609	4109	0009
PCLN R/L 1616 H12	16	16	100	25	20	CN.. 1204..	0,250	8312	1648	5003	3612	4112	0012
PCLN R/L 2020 K12	20	20	125	28	25	CN.. 1204..	0,400	8012	1608	5003	3612	4112	0012
PCLN R/L 2525 M12	25	25	150	28	32	CN.. 1204..	0,750	8012	1608	5003	3612	4112	0012
PCLN R/L 3225 P12	32	25	170	28	32	CN.. 1204..	1,050	8012	1608	5003	3612	4112	0012
PCLN R/L 3232 P12	32	32	170	28	40	CN.. 1204..	1,300	8012	1608	5003	3612	4112	0012
PCLN R/L 2525 M16	25	25	150	34	32	CN.. 1606..	0,750	8016	1618	5003	3616	4115	0015
PCLN R/L 3225 P16	32	25	170	34	32	CN.. 1606..	1,050	8016	1618	5003	3616	4115	0015
PCLN R/L 3232 P16	32	32	170	34	40	CN.. 1606..	1,300	8016	1618	5003	3616	4115	0015
PCLN R/L 4040 S16	40	40	250	45	50	CN.. 1606..	3,050	8016	1618	5003	3616	4115	0015
PCLN R/L 2525 M19	25	25	150	42	32	CN.. 1906..	0,750	8019	1610	5004	3619	4119	0019
PCLN R/L 3225 P19	32	25	170	42	32	CN.. 1906..	1,050	8019	1610	5004	3619	4119	0019
PCLN R/L 3232 P19	32	32	170	42	40	CN.. 1906..	1,300	8019	1610	5004	3619	4119	0019
PCLN R/L 4040 S19	40	40	250	45	50	CN.. 1906..	3,050	8019	1610	5004	3619	4119	0019
PCLN R/L 4040 S25	40	40	250	45	50	CN.. 2509..	3,050	8025	1612	5005	3625	4125	0025
PCLN R/L 5050 T25	50	50	300	50	60	CN.. 2509..	5,850	8025	1612	5005	3625	4125	0025

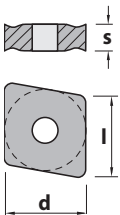

CN..	l	s	d
CN.. 0903..	9,65	3,18	9,52
CN.. 1204..	12,90	4,76	12,70
CN.. 1606..	16,10	6,35	15,88
CN.. 1906..	19,30	6,35	19,05
CN.. 2509..	25,80	9,52	25,40

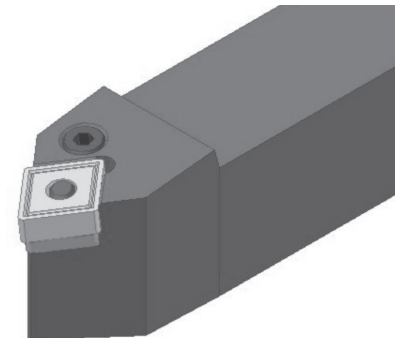
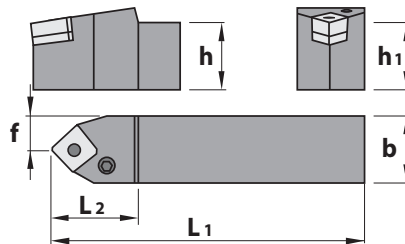
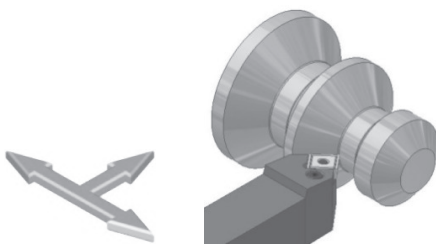
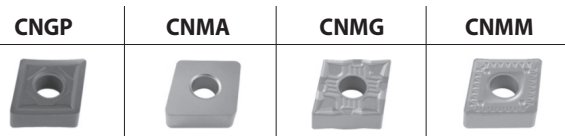

General angle 50°
Главный угол в плане 50°

PCMN

	h=h ₁	b	L ₁	L ₂	f	Plates							
PCMN N 2020 K12	20	20	125	34	10,0	CN.. 1204..	0,400	8012	1608	5003	3612	4112	0012
PCMN N 2525 M12	25	25	150	34	12,5	CN.. 1204..	0,750	8012	1608	5003	3612	4112	0012
PCMN N 3225 P12	32	25	170	34	12,5	CN.. 1204..	1,050	8012	1608	5003	3612	4112	0012
PCMN N 3232 P19	32	32	170	42	16,0	CN.. 1906..	1,300	8019	1610	5004	3619	4119	0019
PCMN N 4040 S19	40	40	250	48	20,0	CN.. 1906..	3,050	8019	1610	5004	3619	4119	0019

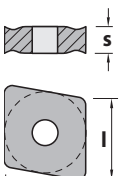

CN..	l	s	d
CN.. 1204..	12,90	4,76	12,70
CN.. 1906..	19,30	6,35	19,05

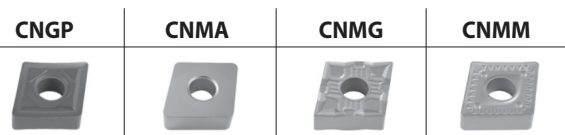

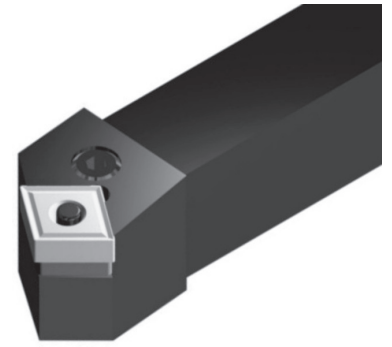
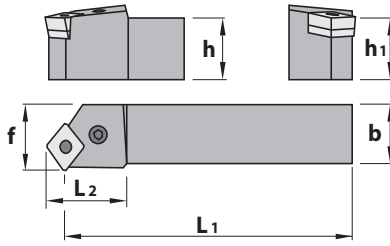
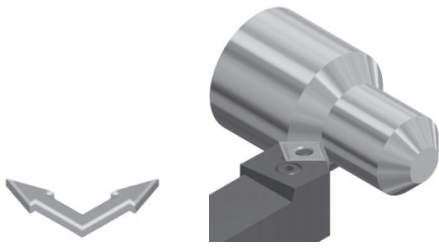

General angle 45°
Главный угол в плане 45°

PCSN

	h=h ₁	b	L ₁	L ₂	f	Plates							
PCSN R/L 2020 K12	20	20	125	28	25	CN.. 1204..	0,400	8012	1608	5003	3612	4112	0012
PCSN R/L 2525 M12	25	25	150	28	32	CN.. 1204..	0,750	8012	1608	5003	3612	4112	0012
PCSN R/L 2525 M16	25	25	150	34	32	CN.. 1606..	0,750	8016	1618	5003	3616	4115	0015
PCSN R/L 3225 P16	32	25	170	34	32	CN.. 1606..	1,050	8016	1618	5003	3616	4115	0015
PCSN R/L 3232 P16	32	32	170	42	40	CN.. 1606..	1,300	8016	1618	5003	3616	4115	0015
PCSN R/L 3225 P19	32	25	170	42	32	CN.. 1906..	1,050	8019	1610	5004	3619	4119	0019
PCSN R/L 3232 P19	32	32	170	42	40	CN.. 1906..	1,300	8019	1610	5004	3619	4119	0019
PCSN R/L 4040 S19	40	40	250	42	50	CN.. 1906..	3,050	8019	1610	5004	3619	4119	0019

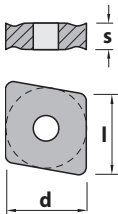

CN..	l	s	d	CNGP	CNMA	CNMG	CNMM
CN.. 1204..	12,90	4,76	12,70				
CN.. 1606..	16,10	6,35	15,88				
CN.. 1906..	19,30	6,35	19,05				

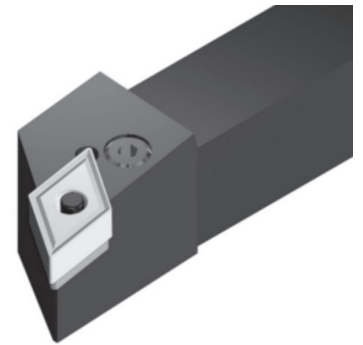
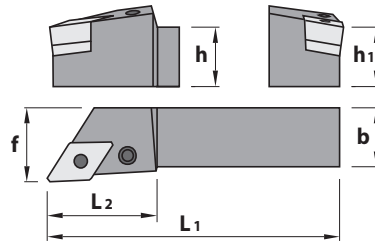
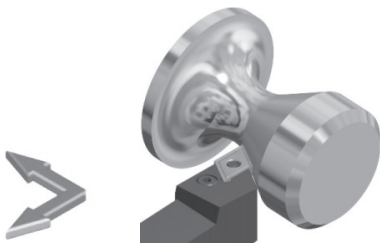

General angle 93°
Главный угол в плане 93°

PDJN

	h=h ₁	b	L ₁	L ₂	f	Plates									
PDJN R/L 1616 H11	16	16	100	25	20	DN.. 1104..	0,250	8009	1606	5025	3711	4109	0009	-	-
PDJN R/L 2020 K11	20	20	125	28	25	DN.. 1104..	0,400	8009	1606	5025	3711	4109	0009	-	-
PDJN R/L 2525 M11	25	25	150	28	32	DN.. 1104..	0,750	8009	1606	5025	3711	4109	0009	-	-
PDJN R/L 3225 P11	32	25	170	28	32	DN.. 1104..	1,050	8009	1606	5025	3711	4109	0009	-	-
PDJN R/L 2020 K15	20	20	125	34	25	DN.. 1506..	0,400	8415	1638	5003	3715	4112	0012	3725	4135
PDJN R/L 2525 M15	25	25	150	34	32	DN.. 1506..	0,750	8415	1638	5003	3715	4112	0012	3725	4135
PDJN R/L 3225 P15	32	25	170	34	32	DN.. 1506..	1,050	8415	1638	5003	3715	4112	0012	3725	4135
PDJN R/L 3232 P15	32	32	170	34	40	DN.. 1506..	1,300	8415	1638	5003	3715	4112	0012	3725	4135
PDJN R/L 4025 R15	40	25	200	34	32	DN.. 1506..	1,850	8415	1638	5003	3715	4112	0012	3725	4135
PDJN R/L 5032 S15	50	32	250	34	40	DN.. 1506..	2,900	8415	1638	5003	3715	4112	0012	3725	4135

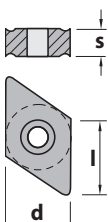

DN..	l	s	d	DNGP	DNMA	DNMG	DNMX
DN.. 1104..	11,60	4,76	9,52				
DN.. 1504..	15,50	4,76	12,70				
DN.. 1506..	15,50	6,35	12,70				

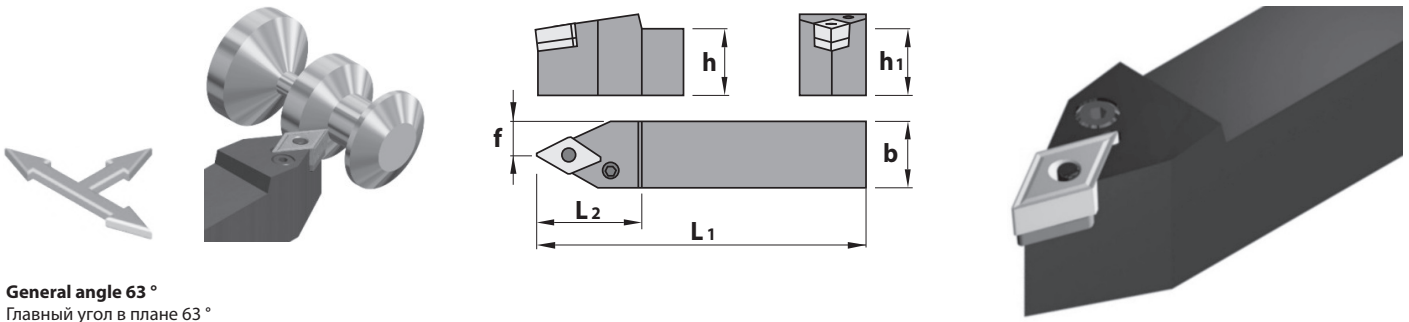

General angle 63°
Главный угол в плане 63°

PDNN

	h=h ₁	b	L ₁	L ₂	f	Plates									
PDNN R/L/N 2020 K15	20	20	125	34	10,0	DN.. 1506..	0,400	8415	1638	5003	3715	4112	0012	3725	4135
PDNN R/L/N 2525 M15	25	25	150	34	12,5	DN.. 1506..	0,750	8415	1638	5003	3715	4112	0012	3725	4135
PDNN R/L/N 3225 P15	32	25	170	34	12,5	DN.. 1506..	1,050	8415	1638	5003	3715	4112	0012	3725	4135
PDNN R/L/N 3232 P15	32	32	170	34	16,0	DN.. 1506..	1,300	8415	1638	5003	3715	4112	0012	3725	4135
PDNN R/L/N 4025 S15	40	25	250	34	12,5	DN.. 1506..	1,850	8415	1638	5003	3715	4112	0012	3725	4135
PDNN R/L/N 5032 S15	50	32	250	34	16,0	DN.. 1506..	2,900	8415	1638	5003	3715	4112	0012	3725	4135

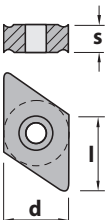

DN..	l	s	d	DNGP	DNMA	DNMG	DNMX
DN.. 1504..	15,50	4,76	12,70				
DN.. 1506..	15,50	6,35	12,70				

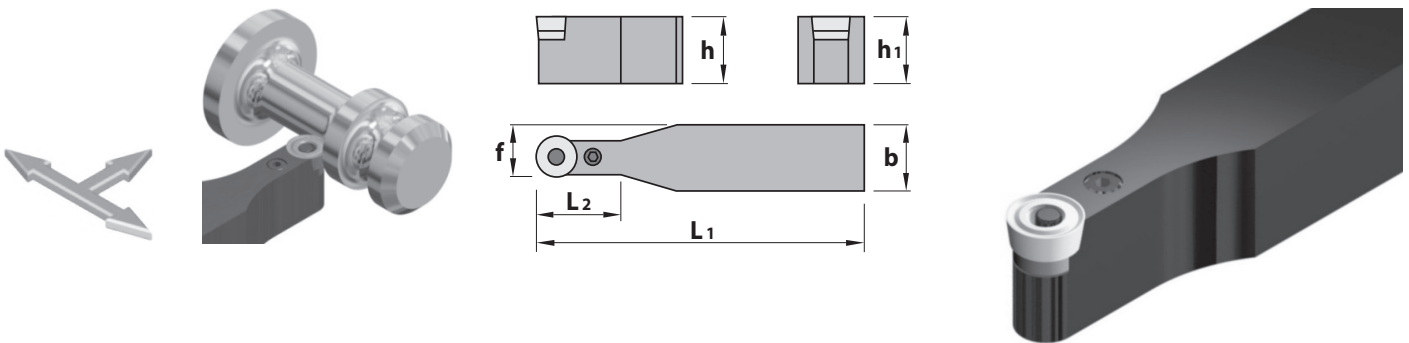

PRDC

	h=h ₁	b	L ₁	L ₂	f	Plates							
PRDC N 2020 K10	20	20	125	22	15,0	RC.. 1003M0	0,400	8110	1705	5002	3810	4110	0009
PRDC N 2525 M10	25	25	150	22	18,5	RC.. 1003M0	0,750	8110	1705	5002	3810	4110	0009
PRDC N 3225 P10	32	25	170	22	18,5	RC.. 1003M0	1,050	8110	1705	5002	3810	4110	0009
PRDC N 2020 K12	20	20	125	28	16,0	RC.. 1204M0	0,400	8112	1606	5025	3812	4110	0009
PRDC N 2525 M12	25	25	150	28	18,5	RC.. 1204M0	0,750	8112	1606	5025	3812	4110	0009
PRDC N 3225 P12	32	25	170	28	18,5	RC.. 1204M0	1,050	8112	1606	5025	3812	4110	0009
PRDC N 4025 S12	40	25	250	28	18,5	RC.. 1204M0	1,850	8112	1606	5025	3812	4110	0009
PRDC N 3225 P16	32	25	170	34	20,5	RC.. 1606M0	1,050	8116	1706	5025	3816	4116	0012
PRDC N 3232 P16	32	32	170	34	24,0	RC.. 1606M0	1,300	8116	1706	5025	3816	4116	0012
PRDC N 3232 P20	32	32	170	42	26,0	RC.. 2006M0	1,300	8120	1708	5003	3820	4115	0015
PRDC N 4040 S20	40	40	250	42	30,0	RC.. 2006M0	3,050	8120	1708	5003	3820	4115	0015
PRDC N 4040 S25	40	40	250	45	32,5	RC.. 2507M0	3,050	8125	1710	5004	3825	4119	0019
PRDC N 4040 U25	40	40	350	45	32,5	RC.. 2507M0	3,050	8125	1710	5004	3825	4119	0019
PRDC N 5050 U25	50	50	350	45	37,5	RC.. 2507M0	5,850	8125	1710	5004	3825	4119	0019
PRDC N 5050 V32	50	50	400	52	41,0	RC.. 3209M0	5,850	8132	1612	5005	3832	4125	0025

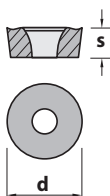

RC..	s	d	RCGT	RCMT
RC.. 1003M0	3,18	10,00		
RC.. 1204M0	4,76	12,00		
RC.. 1606M0	6,35	16,00		
RC.. 2006M0	6,35	20,00		
RC.. 2507M0	7,94	25,00		
RC.. 3209M0	9,52	32,00		

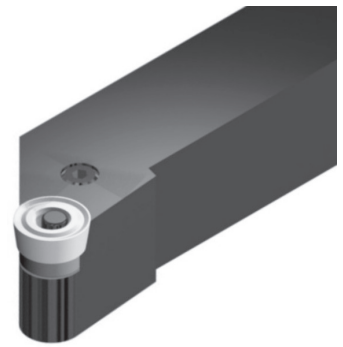
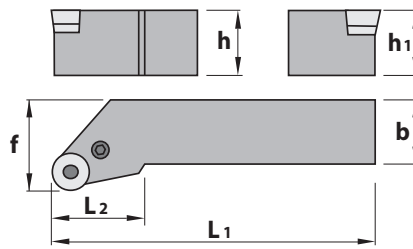
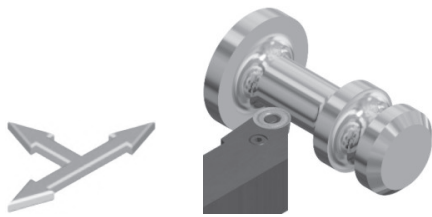

PRSC

	h=h ₁	b	L ₁	L ₂	f	Plates							
PRSC R/L 2020 K10	20	20	125	28	25	RC.. 1003M0	0,400	8110	1705	5002	3810	4110	0009
PRSC R/L 2525 M10	25	25	150	28	32	RC.. 1003M0	0,750	8110	1705	5002	3810	4110	0009
PRSC R/L 3225 P10	32	25	170	28	32	RC.. 1003M0	1,050	8110	1705	5002	3810	4110	0009
PRSC R/L 2020 K12	20	20	125	28	25	RC.. 1204M0	0,400	8112	1606	5025	3812	4110	0009
PRSC R/L 2525 M12	25	25	150	28	32	RC.. 1204M0	0,750	8112	1606	5025	3812	4110	0009
PRSC R/L 3225 P12	32	25	170	28	32	RC.. 1204M0	1,050	8112	1606	5025	3812	4110	0009
PRSC R/L 2525 M16	25	25	150	34	32	RC.. 1606M0	0,750	8116	1706	5025	3816	4116	0012
PRSC R/L 3225 P16	32	25	170	34	32	RC.. 1606M0	1,050	8116	1706	5025	3816	4116	0012
PRSC R/L 3232 P20	32	32	170	42	40	RC.. 2006M0	1,300	8120	1708	5003	3820	4115	0015
PRSC R/L 4040 S20	40	40	250	48	50	RC.. 2006M0	3,050	8120	1708	5003	3820	4115	0015
PRSC R/L 4040 S25	40	40	250	48	50	RC.. 2507M0	3,050	8125	1710	5004	3825	4119	0019
PRSC R/L 5050 T32	50	50	300	50	63	RC.. 3209M0	5,850	8132	1612	5005	3832	4125	0025

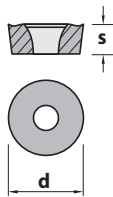

RC..	s	d
RC.. 1003M0	3,18	10,00
RC.. 1204M0	4,76	12,00
RC.. 1606M0	6,35	16,00
RC.. 2006M0	6,35	20,00
RC.. 2507M0	7,94	25,00
RC.. 3209M0	9,52	32,00

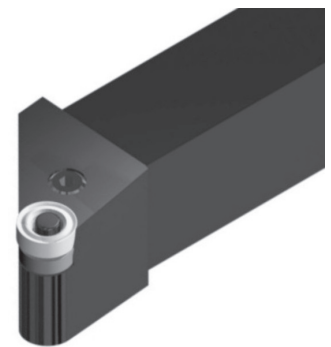
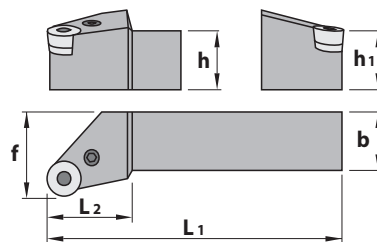
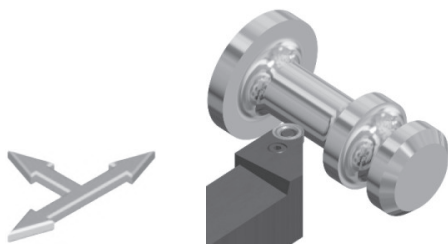
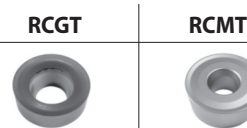

General angle 95°

Главный угол в плане 95°

PRSN

	h=h ₁	b	L ₁	L ₂	f	Plates							
PRSN R/L 2020 K09	20	20	125	22	25	RNMG 090300	0,400	8009	1606	5025	3909	4110	0009
PRSN R/L 2525 M12	25	25	150	28	32	RNMG 120400	0,750	8012	1608	5003	3912	4112	0012
PRSN R/L 3225 P15	32	25	170	34	32	RNMG 150600	1,050	8015	1708	5003	3915	4115	0015
PRSN R/L 3232 P19	32	32	170	42	40	RNMG 190600	1,300	8019	1610	5004	3919	4119	0019
PRSN R/L 4040 S25	40	40	250	45	50	RNMG 250900	3,050	8025	1612	5005	3925	4125	0025

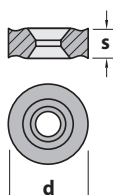

RNMG	s	d
RNMG 090300	3,18	9,52
RNMG 120400	4,76	12,70
RNMG 150600	6,35	15,88
RNMG 190600	6,35	19,05
RNMG 250900	9,52	25,40



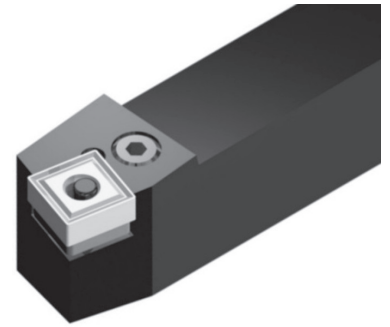
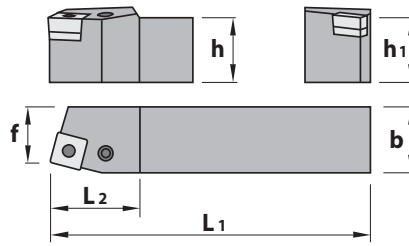
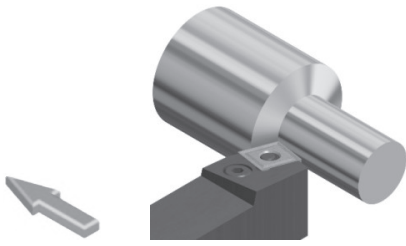

General angle 75°
Главный угол в плане 75°

PSBN

	h=h ₁	b	L ₁	L ₂	f	Plates							
PSBN R/L 1212 F09	12	12	80	18	11	SNM.. 0903..	0,100	8005	1715	5002	-	-	-
PSBN R/L 1616 H09	16	16	100	22	13	SNM.. 0903..	0,250	8009	1606	5025	3509	4110	0009
PSBN R/L 2020 K09	20	20	125	22	17	SNM.. 0903..	0,400	8009	1606	5025	3509	4110	0009
PSBN R/L 2020 K12	20	20	125	28	17	SNM.. 1204..	0,400	8012	1608	5003	3512	4112	0012
PSBN R/L 2525 M12	25	25	150	28	22	SNM.. 1204..	0,750	8012	1608	5003	3512	4112	0012
PSBN R/L 3225 P12	32	25	170	28	22	SNM.. 1204..	1,050	8012	1608	5003	3512	4112	0012
PSBN R/L 2525 M15	25	25	150	34	22	SNM.. 1506..	0,750	8016	1618	5003	3515	4115	0015
PSBN R/L 3232 P15	32	32	170	34	27	SNM.. 1506..	1,300	8016	1618	5003	3515	4115	0015
PSBN R/L 3232 P19	32	32	170	42	27	SNM.. 1906..	1,300	8019	1610	5004	3519	4119	0019
PSBN R/L 4040 S19	40	40	250	48	35	SNM.. 1906..	3,050	8019	1610	5004	3519	4119	0019
PSBN R/L 4040 S25	40	40	250	48	35	SNM.. 2507..	3,050	8025	1612	5005	3525	4125	0025
PSBN R/L 5050 T25	50	50	300	50	43	SNM.. 2507..	5,850	8025	1612	5005	3525	4125	0025

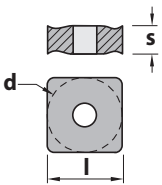

SNM..	l	s	d	SNMA	SNMG	SNMM
SNM.. 0903..	9,52	3,18	9,52			
SNM.. 1204..	12,70	4,76	12,70			
SNM.. 1506..	15,88	6,35	15,88			
SNM.. 1906..	19,05	6,35	19,05			
SNM.. 2507..	25,40	7,94	25,40			

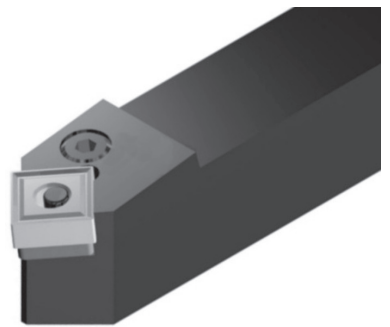
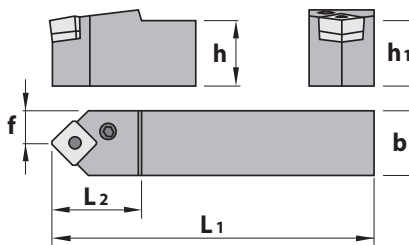
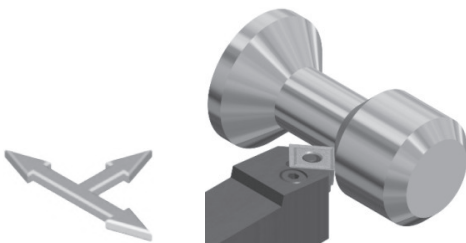

General angle 45°
Главный угол в плане 45°

PSDN

	h=h ₁	b	L ₁	L ₂	f	Plates							
PSDN N 1010 E09	10	10	70	16	5,0	SNM.. 0903..	0,070	8005	1715	5002	-	-	-
PSDN N 1212 F09	12	12	80	20	6,0	SNM.. 0903..	0,100	8005	1715	5002	-	-	-
PSDN N 1616 H09	16	16	100	22	8,0	SNM.. 0903..	0,250	8009	1606	5025	3509	4110	0009
PSDN N 2020 K12	20	20	125	28	10,0	SNM.. 1204..	0,400	8012	1608	5003	3512	4112	0012
PSDN N 2525 M12	25	25	150	28	12,5	SNM.. 1204..	0,750	8012	1608	5003	3512	4112	0012
PSDN N 3225 P12	32	25	170	34	12,5	SNM.. 1204..	1,050	8012	1608	5003	3512	4112	0012
PSDN N 3232 P12	32	32	170	34	16,0	SNM.. 1204..	1,300	8012	1608	5003	3512	4112	0012
PSDN N 3225 P19	32	25	170	34	12,5	SNM.. 1906..	1,050	8019	1610	5004	3519	4119	0019
PSDN N 3232 P19	32	32	170	42	16,0	SNM.. 1906..	1,300	8019	1610	5004	3519	4119	0019
PSDN N 4040 S25	40	40	250	48	20,0	SNM.. 2507..	3,050	8025	1612	5005	3525	4125	0025
PSDN N 5050 T25	50	50	300	50	25,0	SNM.. 2507..	5,850	8025	1612	5005	3525	4125	0025

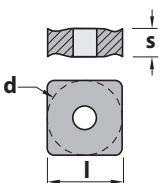

SNM..	l	s	d	SNMA	SNMG	SNMM
SNM.. 0903..	9,52	3,18	9,52			
SNM.. 1204..	12,70	4,76	12,70			
SNM.. 1906..	19,05	6,35	19,05			
SNM.. 2507..	25,40	7,94	25,40			

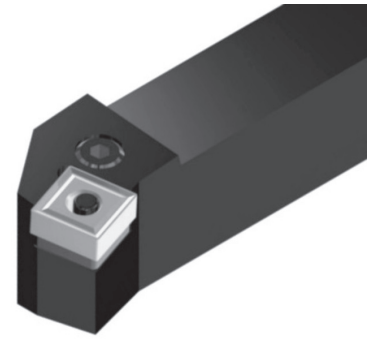
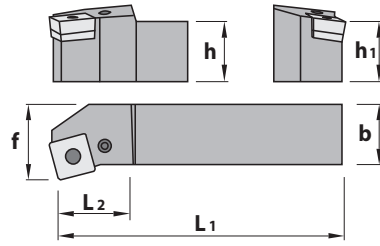
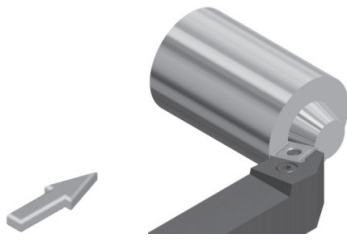

General angle 75°
Главный угол в плане 75°

PSKN

	h=h ₁	b	L ₁	L ₂	f	Plates	kg						
PSKN R/L 1616 H09	16	16	100	22	20	SNM.. 0903..	0,250	8009	1606	5025	3509	4110	0009
PSKN R/L 2020 K09	20	20	125	22	25	SNM.. 0903..	0,400	8009	1606	5025	3509	4110	0009
PSKN R/L 2020 K12	20	20	125	28	25	SNM.. 1204..	0,400	8012	1608	5003	3512	4112	0012
PSKN R/L 2525 M12	25	25	150	28	32	SNM.. 1204..	0,750	8012	1608	5003	3512	4112	0012
PSKN R/L 3225 P12	32	25	170	34	32	SNM.. 1204..	1,050	8012	1608	5003	3512	4112	0012
PSKN R/L 2525 M15	25	25	150	34	32	SNM.. 1506..	0,750	8016	1618	5003	3515	4115	0015
PSKN R/L 3232 P15	32	32	170	42	40	SNM.. 1506..	1,300	8016	1618	5003	3515	4115	0015
PSKN R/L 3232 P19	32	32	170	42	40	SNM.. 1906..	1,300	8019	1610	5004	3519	4119	0019
PSKN R/L 4040 S19	40	40	250	45	50	SNM.. 1906..	3,050	8019	1610	5004	3519	4119	0019
PSKN R/L 4040 S25	40	40	250	45	50	SNM.. 2507..	3,050	8025	1612	5005	3525	4125	0025
PSKN R/L 5050 T25	50	50	300	50	60	SNM.. 2507..	5,850	8025	1612	5005	3525	4125	0025

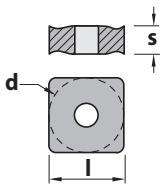

SNM..	l	s	d	SNMA	SNMG	SNMM
SNM.. 0903..	9,52	3,18	9,52			
SNM.. 1204..	12,70	4,76	12,70			
SNM.. 1506..	15,88	6,35	15,88			
SNM.. 1906..	19,05	6,35	19,05			
SNM.. 2507..	25,40	7,94	25,40			

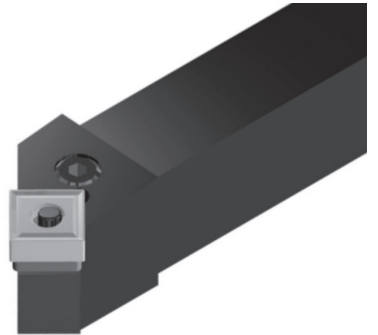
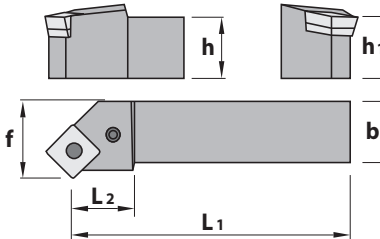
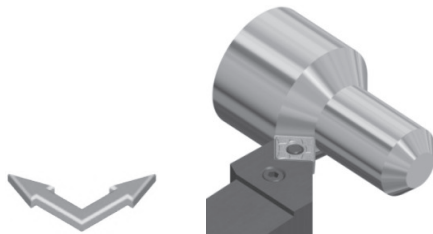

General angle 45°
Главный угол в плане 45°

PSSN

	h=h ₁	b	L ₁	L ₂	f	Plates	kg						
PSSN R/L 1616 H09	16	16	100	22	20	SNM.. 0903..	0,250	8009	1606	5025	3509	4110	0009
PSSN R/L 2020 K09	20	20	125	25	25	SNM.. 0903..	0,400	8009	1606	5025	3509	4110	0009
PSSN R/L 2020 K12	20	20	125	28	25	SNM.. 1204..	0,400	8012	1608	5003	3512	4112	0012
PSSN R/L 2525 M12	25	25	150	28	32	SNM.. 1204..	0,750	8012	1608	5003	3512	4112	0012
PSSN R/L 3225 P12	32	25	170	28	32	SNM.. 1204..	1,050	8012	1608	5003	3512	4112	0012
PSSN R/L 2525 M15	25	25	150	34	32	SNM.. 1506..	0,750	8016	1618	5003	3515	4115	0015
PSSN R/L 3232 P15	32	32	170	42	40	SNM.. 1506..	1,300	8016	1618	5003	3515	4115	0015
PSSN R/L 3232 P19	32	32	170	45	40	SNM.. 1906..	1,300	8019	1610	5004	3519	4119	0019
PSSN R/L 4040 S19	40	40	250	45	50	SNM.. 1906..	3,050	8019	1610	5004	3519	4119	0019
PSSN R/L 5050 T19	50	50	300	50	60	SNM.. 1906..	5,850	8019	1610	5004	3519	4119	0019
PSSN R/L 4040 S25	40	40	250	45	50	SNM.. 2507..	3,050	8025	1612	5005	3525	4125	0025
PSSN R/L 5050 T25	50	50	300	50	60	SNM.. 2507..	5,850	8025	1612	5005	3525	4125	0025

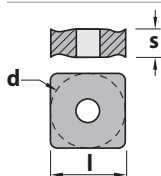

SNM..	l	s	d	SNMA	SNMG	SNMM
SNM.. 0903..	9,52	3,18	9,52			
SNM.. 1204..	12,70	4,76	12,70			
SNM.. 1506..	15,88	6,35	15,88			
SNM.. 1906..	19,05	6,35	19,05			
SNM.. 2507..	25,40	7,94	25,40			

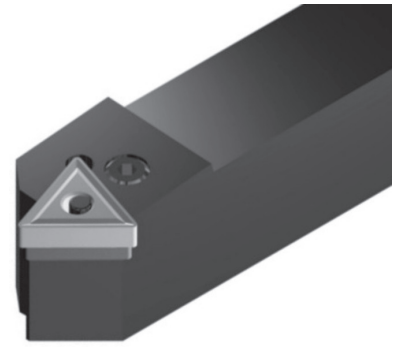
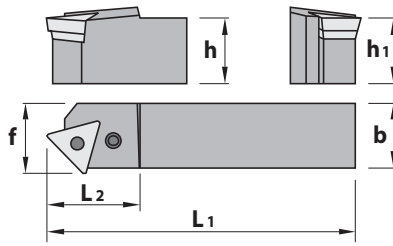
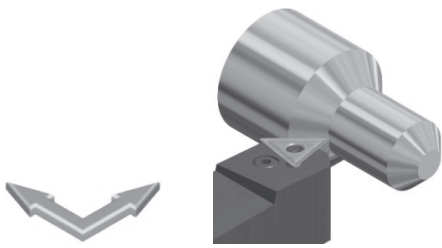

General angle 45°
Главный угол в плане 45°

PTDN

	h=h ₁	b	L ₁	L ₂	f	Plates							
PTDN R/L 2525 M22	25	25	150	34	27	TNM.. 2204..	0,750	8012	1608	5003	3422	4112	0012
PTDN R/L 3225 P22	32	25	170	34	27	TNM.. 2204..	1,050	8012	1608	5003	3422	4112	0012

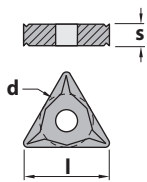

TNM..	l	s	d	TNMA	TNMG
TNM.. 2204..	22,00	4,76	12,70		

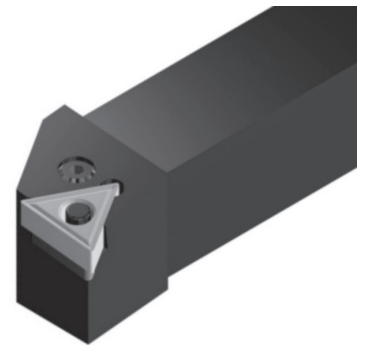
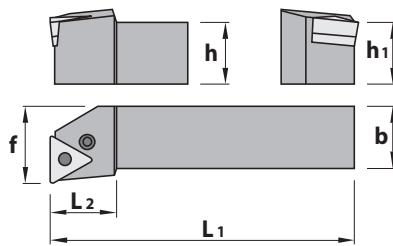
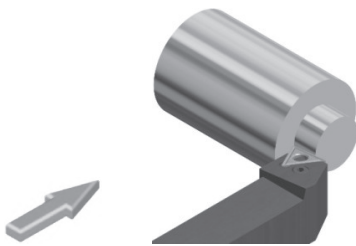

General angle 90°
Главный угол в плане 90°

PTFN

	h=h ₁	b	L ₁	L ₂	f	Plates							
PTFN R/L 1616 H16	16	16	100	22	20	TNM.. 1604..	0,250	8009	1606	5025	3416	4109	0009
PTFN R/L 2020 K16	20	20	125	22	25	TNM.. 1604..	0,400	8009	1606	5025	3416	4109	0009
PTFN R/L 2525 M16	25	25	150	28	32	TNM.. 1604..	0,750	8009	1606	5025	3416	4109	0009
PTFN R/L 3225 P16	32	25	170	28	32	TNM.. 1604..	1,050	8009	1606	5025	3416	4109	0009
PTFN R/L 2525 M22	25	25	150	28	32	TNM.. 2204..	0,750	8012	1608	5003	3422	4112	0012
PTFN R/L 3225 P22	32	25	170	28	32	TNM.. 2204..	1,050	8012	1608	5003	3422	4112	0012
PTFN R/L 3232 P22	32	32	170	28	40	TNM.. 2204..	1,300	8012	1608	5003	3422	4112	0012
PTFN R/L 3232 P27	32	32	170	42	40	TNM.. 2706..	1,300	8015	1708	5003	3427	4115	0015
PTFN R/L 4040 S27	40	40	250	45	50	TNM.. 2706..	3,050	8015	1708	5003	3427	4115	0015

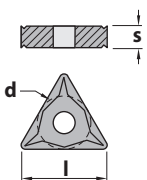

TNM..	l	s	d	TNMA	TNMG
TNM.. 1604..	16,50	4,76	9,52		
TNM.. 2204..	22,00	4,76	12,70		
TNM.. 2706..	27,50	6,35	15,88		

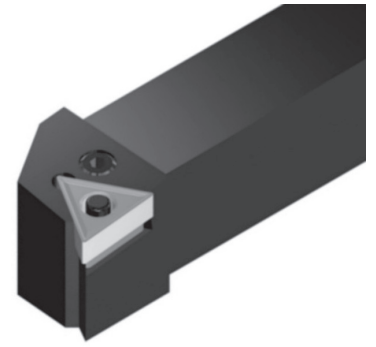
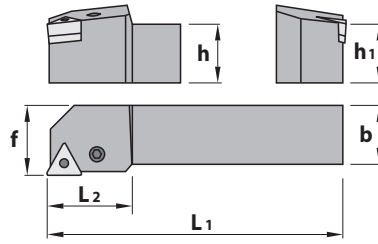
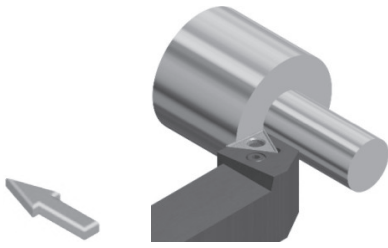

General angle 90°
Главный угол в плане 90°

PTGN

	h=h ₁	b	L ₁	L ₂	f	Plates							
PTGN R/L 1616 H16	16	16	100	22	20	TNM.. 1604..	0,250	8009	1606	5025	3416	4109	0009
PTGN R/L 2020 K16	20	20	125	22	25	TNM.. 1604..	0,400	8009	1606	5025	3416	4109	0009
PTGN R/L 2525 M16	25	25	150	28	32	TNM.. 1604..	0,750	8009	1606	5025	3416	4109	0009
PTGN R/L 3225 P16	32	25	170	28	32	TNM.. 1604..	1,050	8009	1606	5025	3416	4109	0009
PTGN R/L 2525 M22	25	25	150	28	32	TNM.. 2204..	0,750	8012	1608	5003	3422	4112	0012
PTGN R/L 3225 P22	32	25	170	28	32	TNM.. 2204..	1,050	8012	1608	5003	3422	4112	0012
PTGN R/L 3232 P22	32	32	170	28	40	TNM.. 2204..	1,300	8012	1608	5003	3422	4112	0012
PTGN R/L 4040 S22	40	40	250	45	50	TNM.. 2204..	3,050	8012	1608	5003	3422	4112	0012
PTGN R/L 3232 P27	32	32	170	42	40	TNM.. 2706..	1,300	8015	1708	5003	3427	4115	0015
PTGN R/L 4040 S27	40	40	250	45	50	TNM.. 2706..	3,050	8015	1708	5003	3427	4115	0015
PTGN R/L 5050 T33	50	50	300	50	60	TNM.. 3307..	5,850	8019	1610	5004	3433	4133	0019

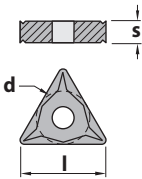

TNM..	l	s	d
TNM.. 1604..	16,50	4,76	9,52
TNM.. 2204..	22,00	4,76	12,70
TNM.. 2706..	27,50	6,35	15,88
TNM.. 3307..	33,00	7,93	19,05

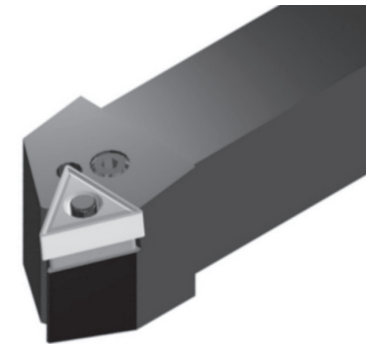
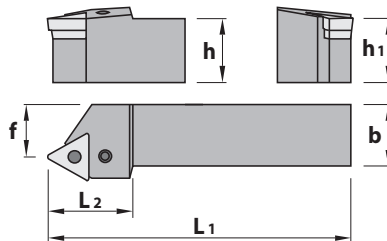
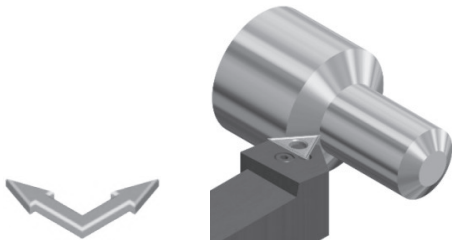

General angle 60°
Главный угол в плане 60°

PTTN

	h=h ₁	b	L ₁	L ₂	f	Plates							
PTTN R/L 1616 H16	16	16	100	25	13	TNM.. 1604..	0,250	8009	1606	5025	3416	4109	0009
PTTN R/L 2020 K16	20	20	125	28	17	TNM.. 1604..	0,400	8009	1606	5025	3416	4109	0009
PTTN R/L 2525 M16	25	25	150	28	22	TNM.. 1604..	0,750	8009	1606	5025	3416	4109	0009
PTTN R/L 2525 M22	25	25	150	34	22	TNM.. 2204..	0,750	8012	1608	5003	3422	4112	0012
PTTN R/L 3225 P22	32	25	170	34	22	TNM.. 2204..	1,050	8012	1608	5003	3422	4112	0012

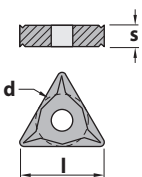

TNM..	l	s	d
TNM.. 1604..	16,50	4,76	9,52
TNM.. 2204..	22,00	4,76	12,70



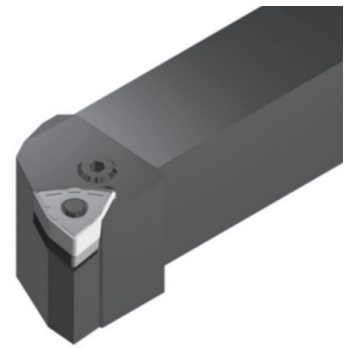
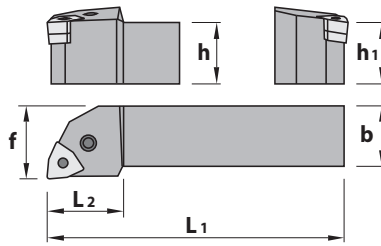
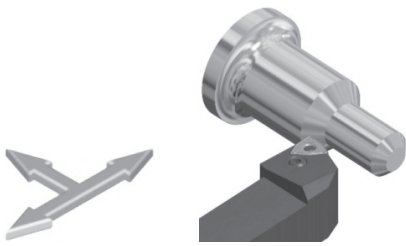

General angle 95°
Главный угол в плане 95°

PWLN

	h=h ₁	b	L ₁	L ₂	f	Plates								
PWLN R/L 1616 H06	16	16	100	22	20	WNM..0604..	0,250	8009	1606	5025	3007	4109	0009	
PWLN R/L 2020 K06	20	20	125	22	25	WNM..0604..	0,400	8009	1606	5025	3007	4109	0009	
PWLN R/L 2525 M06	25	25	150	25	32	WNM..0604..	0,750	8009	1606	5025	3007	4109	0009	
PWLN R/L 2020 K08	20	20	125	28	25	WNM..0804..	0,400	8012	1608	5003	3008	4112	0012	
PWLN R/L 2525 M08	25	25	150	28	32	WNM..0804..	0,750	8012	1608	5003	3008	4112	0012	
PWLN R/L 3225 P08	32	25	170	34	32	WNM..0804..	1,050	8012	1608	5003	3008	4112	0012	
PWLN R/L 3232 P08	32	32	170	34	40	WNM..0804..	1,300	8012	1608	5003	3008	4112	0012	

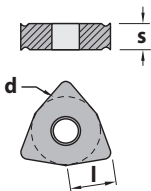

WNM..	l	s	d	WNMA	WNMG
WNM..0604..	6,45	4,76	9,52		
WNM..0804..	8,14	4,76	12,70		

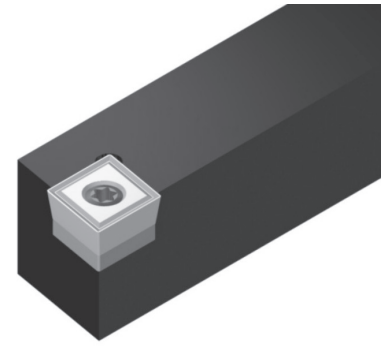
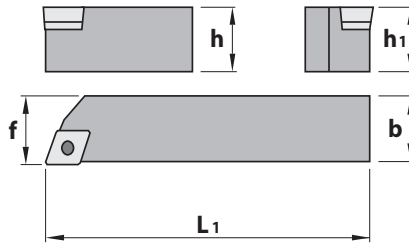
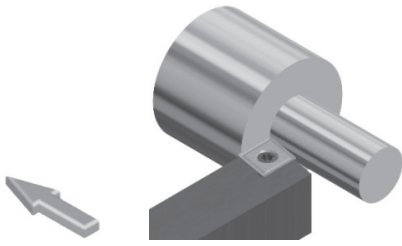

General angle 90°
Главный угол в плане 90°

SCAC

	h=h ₁	b	L ₁	f	Plates					
SCAC R/L 0808 D06	8	8	60	8,5	CC.. 0602..	0,050	1225	5507	-	-
SCAC R/L 1010 E06	10	10	70	10,5	CC.. 0602..	0,070	1225	5507	-	-
SCAC R/L 1212 F09	12	12	80	12,5	CC.. 09T3..	0,100	1240	5515	-	-
SCAC R/L 1616 H09	16	16	100	16,5	CC.. 09T3..	0,200	1240	5515	-	-
SCAC R/L 2020 K12	20	20	125	20,5	CC.. 1204..	0,400	1540	5517	3614	1760
SCAC R/L 2525 M12	25	25	150	25,5	CC.. 1204..	0,700	1540	5517	3614	1760

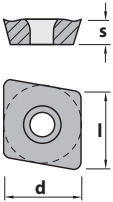

CC..	l	s	d	CCGT	CCMT	CCMW
CC.. 0602..	6,45	2,38	6,35			
CC.. 09T3..	9,65	3,97	9,52			
CC.. 1204..	12,90	4,76	12,70			

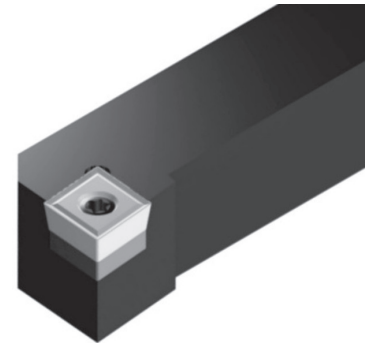
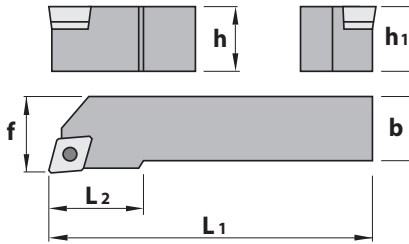
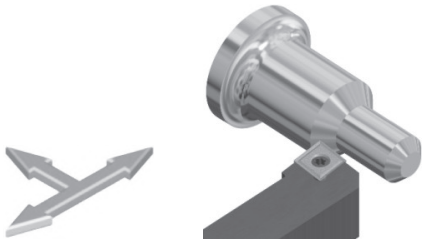

General angle 95°
Главный угол в плане 95°

SCLC

	h=h ₁	b	L ₁	L ₂	f	Plates					
SCLC R/L 0808 D06	8	8	60	12	10	CC.. 0602..	0,050	1225	5507	-	-
SCLC R/L 1010 E06	10	10	70	14	12	CC.. 0602..	0,070	1225	5507	-	-
SCLC R/L 1212 F09	12	12	80	16	16	CC.. 09T3..	0,100	1240	5515	-	-
SCLC R/L 1616 H09	16	16	100	18	20	CC.. 09T3..	0,200	1240	5515	-	-
SCLC R/L 2020 K09	20	20	125	22	25	CC.. 09T3..	0,400	1240	5515	-	-
SCLC R/L 2020 K12	20	20	125	22	25	CC.. 1204..	0,400	1540	5517	3614	1760
SCLC R/L 2525 M12	25	25	150	28	32	CC.. 1204..	0,700	1540	5517	3614	1760

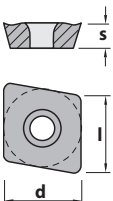

CC..	l	s	d	CCGT	CCMT	CCMW
CC.. 0602..	6,45	2,38	6,35			
CC.. 09T3..	9,65	3,97	9,52			
CC.. 1204..	12,90	4,76	12,70			

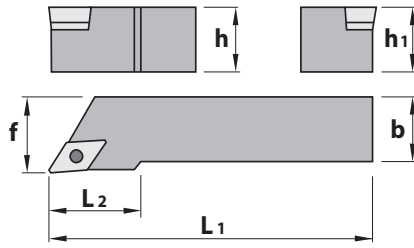
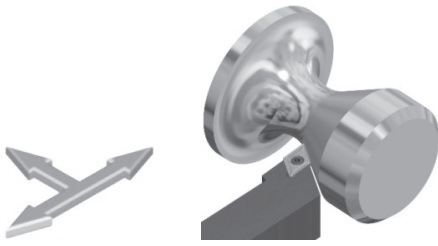

General angle 93°
Главный угол в плане 93°

SDJC

	h=h ₁	b	L ₁	L ₂	f	Plates					
SDJC R/L 1010 E07	10	10	70	14	12	DC.. 0702..	0,070	1225	5507	-	-
SDJC R/L 1212 F07	12	12	80	16	16	DC.. 0702..	0,100	1225	5507	-	-
SDJC R/L 1212 F11	12	12	80	18	16	DC.. 11T3..	0,100	1240	5515	-	-
SDJC R/L 1616 H11	16	16	100	18	20	DC.. 11T3..	0,200	1335	5516	3714	1750
SDJC R/L 2020 K11	20	20	125	22	25	DC.. 11T3..	0,400	1335	5516	3714	1750
SDJC R/L 2525 M11	25	25	150	28	32	DC.. 11T3..	0,700	1335	5516	3714	1750

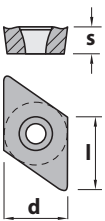

DC..	l	s	d
DC.. 0702..	7,75	2,38	6,35
DC.. 11T3..	11,60	3,97	9,52

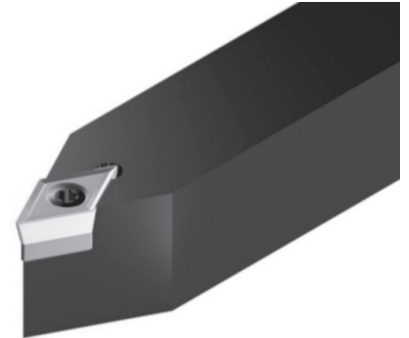
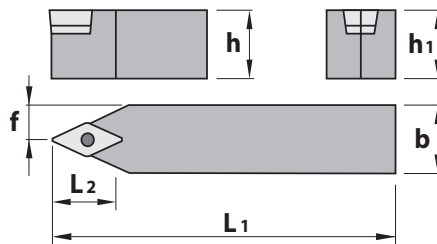
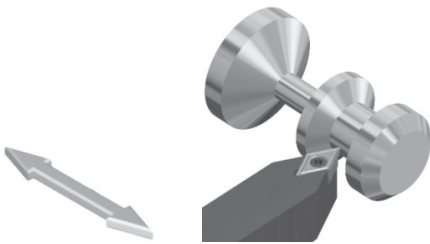
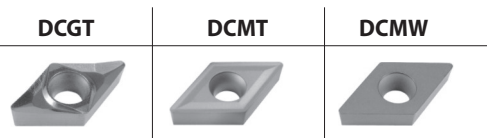

General angle 62°30'
Главный угол в плане 62°30'

SDNC

	h=h ₁	b	L ₁	L ₂	f	Plates					
SDNC N 0808 D07	8	8	60	16	4,0	DC.. 0702..	0,050	1225	5507	-	-
SDNC N 1010 E07	10	10	70	16	5,0	DC.. 0702..	0,070	1225	5507	-	-
SDNC N 1212 F07	12	12	80	18	6,0	DC.. 0702..	0,100	1225	5507	-	-
SDNC N 1616 H11	16	16	100	22	8,0	DC.. 11T3..	0,200	1335	5516	3714	1750
SDNC N 2020 K11	20	20	125	22	10,0	DC.. 11T3..	0,400	1335	5516	3714	1750
SDNC N 2525 M11	25	25	150	22	12,5	DC.. 11T3..	0,700	1335	5516	3714	1750

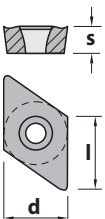

DC..	l	s	d
DC.. 0702..	7,75	2,38	6,35
DC.. 11T3..	11,60	3,97	9,52

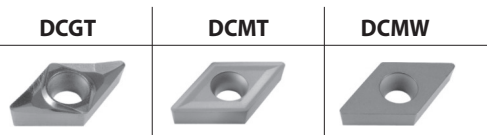

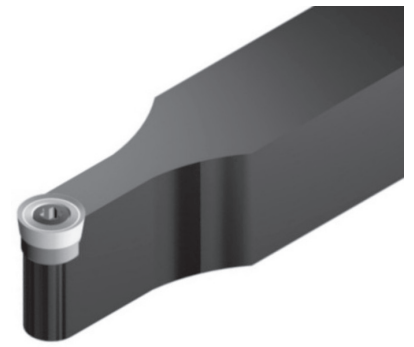
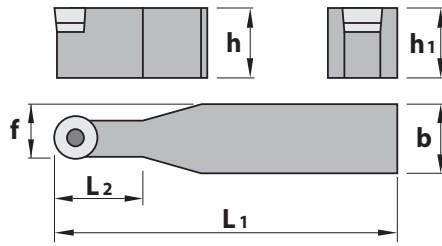
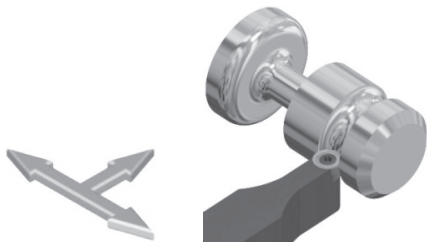

SRDC

	h=h ₁	b	L ₁	L ₂	f	Plates					
SRDC N 1010 E06	10	10	70	10	8,0	RC.. 0602M0	0,070	1225	5507	-	-
SRDC N 1212 F06	12	12	80	12	11,0	RC.. 0602M0	0,100	1225	5507	-	-
SRDC N 1616 H06	16	16	100	16	13,0	RC.. 0602M0	0,200	1225	5507	-	-
SRDC N 2020 K06	20	20	125	20	15,0	RC.. 0602M0	0,400	1225	5507	-	-
SRDC N 2525 M06	25	25	150	25	17,5	RC.. 0602M0	0,700	1225	5507	-	-
SRDC N 1616 H08	16	16	100	16	13,0	RC.. 0803M0	0,200	1230	5508	-	-
SRDC N 2020 K08	20	20	125	20	15,0	RC.. 0803M0	0,400	1230	5508	-	-
SRDC N 2525 M08	25	25	150	25	17,5	RC.. 0803M0	0,700	1230	5508	-	-
SRDC N 2020 K10	20	20	125	22	15,0	RC.. 10T3M0	0,400	1335	5516	3811	1750
SRDC N 2525 M10	25	25	150	22	17,5	RC.. 10T3M0	0,700	1335	5516	3811	1750
SRDC N 2020 K12	20	20	125	28	16,0	RC.. 1204M0	0,400	1335	5516	3814	1750
SRDC N 2525 M12	25	25	150	28	18,5	RC.. 1204M0	0,700	1335	5516	3814	1750
SRDC N 3225 P12	32	25	170	28	18,5	RC.. 1204M0	0,900	1335	5516	3814	1750
SRDC N 3225 P12	32	32	170	28	22,0	RC.. 1204M0	1,200	1335	5516	3814	1750

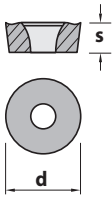

RC..	s	d
RC.. 0602M0	2,38	6,00
RC.. 0803M0	3,18	8,00
RC.. 10T3M0	3,97	10,00
RC.. 1204M0	4,76	12,00

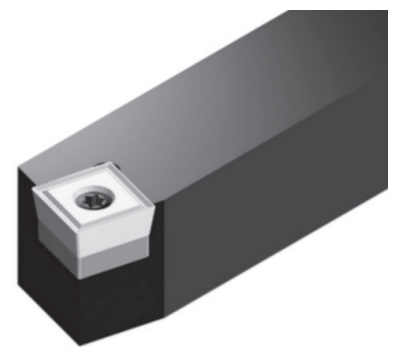
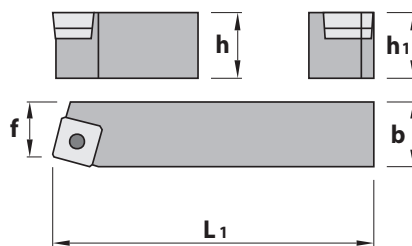
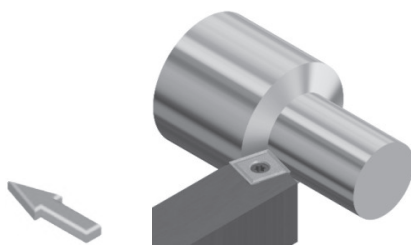
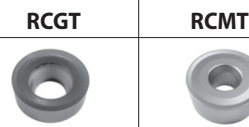

General angle 75°
Главный угол в плане 75°

SSBC

	h=h ₁	b	L ₁	f	Plates					
SSBC R/L 1212 F09	12	12	80	11	SC.. 09T3..	0,100	1240	5515	-	-
SSBC R/L 1616 H09	16	16	100	13	SC.. 09T3..	0,200	1240	5515	-	-
SSBC R/L 2020 K12	20	20	125	17	SC.. 1204..	0,400	1540	5517	3514	1760
SSBC R/L 2525 M12	25	25	150	22	SC.. 1204..	0,700	1540	5517	3514	1760

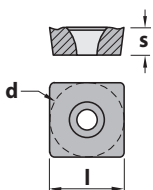

SC..	l	s	d
SC.. 09T3..	9,52	3,97	9,52
SC.. 1204..	12,70	4,76	12,70



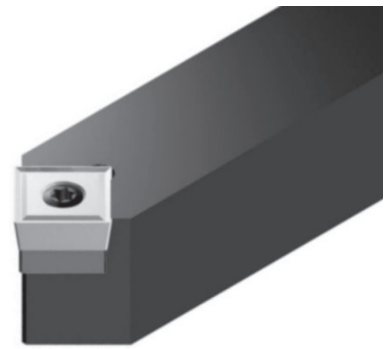
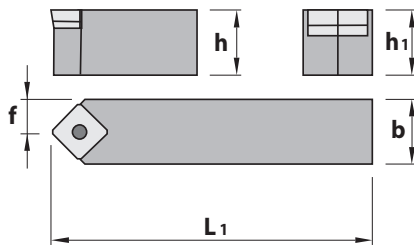
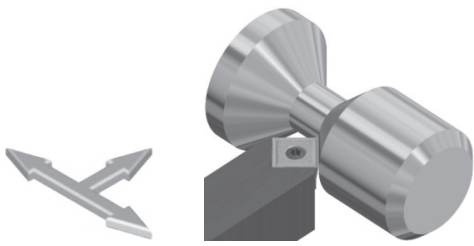

General angle 45°
Главный угол в плане 45°

SSDC

	h=h ₁	b	L ₁	f	Plates					
SSDC N 1212 F09	12	12	80	6,0	SC.. 09T3..	0,100	1240	5515	-	-
SSDC N 1616 H09	16	16	100	8,0	SC.. 09T3..	0,200	1240	5515	-	-
SSDC N 2020 K12	20	20	125	10,0	SC.. 1204..	0,400	1540	5517	3514	1760
SSDC N 2525 M12	25	25	150	12,5	SC.. 1204..	0,700	1540	5517	3514	1760

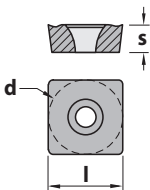

SC..	l	s	d	SCGT	SCMT	SCMW
SC.. 09T3..	9,52	3,97	9,52			
SC.. 1204..	12,70	4,76	12,70			

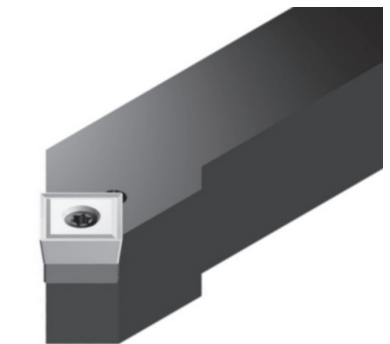
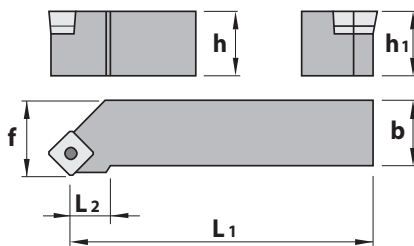
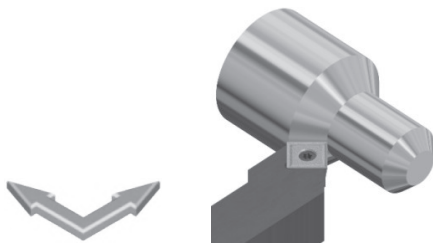

General angle 45°
Главный угол в плане 45°

SSSC

	h=h ₁	b	L ₁	L ₂	f	Plates					
SSSC R/L 1212 F09	12	12	80	20	16	SC.. 09T3..	0,100	1240	5515	-	-
SSSC R/L 1616 H09	16	16	100	22	20	SC.. 09T3..	0,200	1240	5515	-	-
SSSC R/L 2020 K12	20	20	125	25	25	SC.. 1204..	0,400	1540	5517	3514	1760
SSSC R/L 2525 M12	25	25	150	28	32	SC.. 1204..	0,700	1540	5517	3514	1760

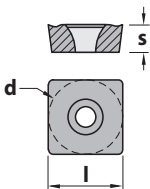

SC..	l	s	d	SCGT	SCMT	SCMW
SC.. 09T3..	9,52	3,97	9,52			
SC.. 1204..	12,70	4,76	12,70			

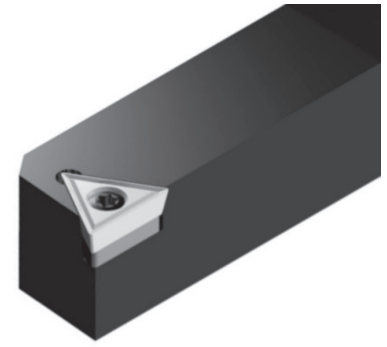
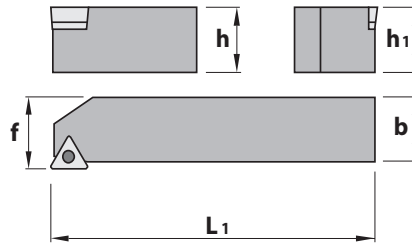
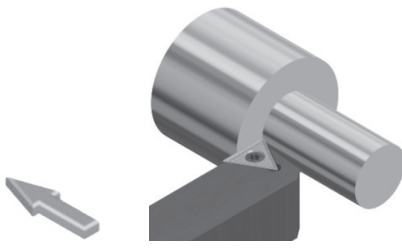

General angle 90°
Главный угол в плане 90°

STAC

	h=h ₁	b	L ₁	f	Plates					
STAC R/L 0808 D09	8	8	60	8,5	TC.. 0902..	0,050	1222	5506	-	-
STAC R/L 1010 E09	10	10	70	10,5	TC.. 0902..	0,070	1222	5506	-	-
STAC R/L 1212 F11	12	12	80	12,5	TC.. 1102..	0,100	1225	5507	-	-
STAC R/L 1616 H11	16	16	100	16,5	TC.. 1102..	0,200	1225	5507	-	-
STAC R/L 1616 H16	16	16	100	16,5	TC.. 16T3..	0,200	1335	5516	3414	1750
STAC R/L 2020 K16	20	20	125	20,5	TC.. 16T3..	0,400	1335	5516	3414	1750
STAC R/L 2525 M16	25	25	150	25,5	TC.. 16T3..	0,700	1335	5516	3414	1750

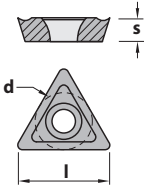

TC..	l	s	d
TC.. 0902..	9,62	2,38	5,55
TC.. 1102..	11,00	2,38	6,35
TC.. 16T3..	16,50	3,97	9,52

TCGT	TCMT	TCMW

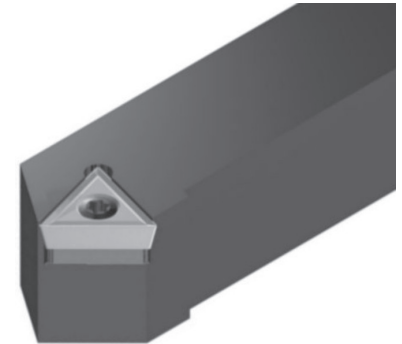
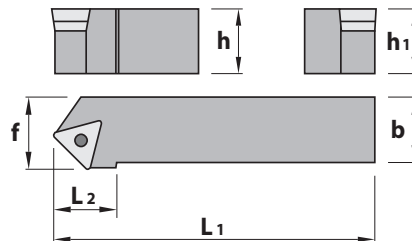
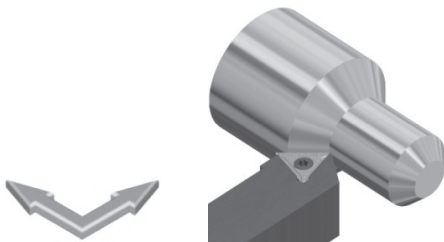

General angle 45°
Главный угол в плане 45°

STDC

	h=h ₁	b	L ₁	L ₂	f	Plates					
STDC R/L 0808 D09	8	8	60	12	10	TC.. 0902..	0,050	1222	5506	-	-
STDC R/L 1010 E09	10	10	70	14	11	TC.. 0902..	0,070	1222	5506	-	-
STDC R/L 1212 F11	12	12	80	16	13	TC.. 1102..	0,100	1225	5507	-	-
STDC R/L 1616 H11	16	16	100	18	17	TC.. 1102..	0,200	1225	5507	-	-
STDC R/L 1212 F16	12	12	80	18	17	TC.. 16T3..	0,100	1240	5515	-	-
STDC R/L 1616 H16	16	16	100	18	17	TC.. 16T3..	0,200	1335	5516	3414	1750
STDC R/L 2020 K16	20	20	125	22	22	TC.. 16T3..	0,400	1335	5516	3414	1750
STDC R/L 2525 M16	25	25	150	28	27	TC.. 16T3..	0,700	1335	5516	3414	1750

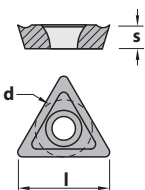

TC..	l	s	d
TC.. 0902..	9,62	2,38	5,55
TC.. 1102..	11,00	2,38	6,35
TC.. 16T3..	16,50	3,97	9,52

TCGT	TCMT	TCMW

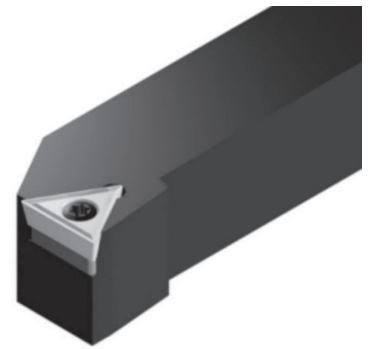
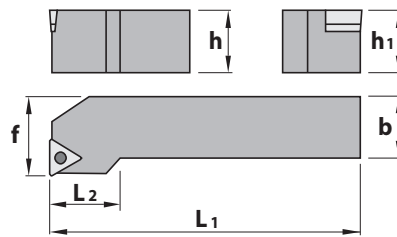
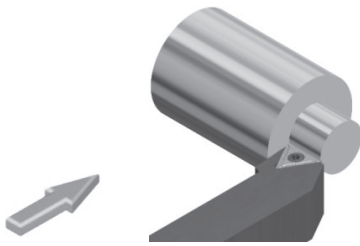

General angle 90°
Главный угол в плане 90°

STFC

	h=h ₁	b	L ₁	L ₂	f	Plates					
STFC R/L 0808 D09	8	8	60	12	10	TC.. 0902..	0,050	1222	5506	-	-
STFC R/L 1010 E09	10	10	70	14	12	TC.. 0902..	0,070	1222	5506	-	-
STFC R/L 1212 F11	12	12	80	16	16	TC.. 1102..	0,100	1225	5507	-	-
STFC R/L 1616 H11	16	16	100	18	20	TC.. 1102..	0,200	1225	5507	-	-
STFC R/L 1212 F16	12	12	80	16	16	TC.. 16T3..	0,100	1240	5515	-	-
STFC R/L 1616 H16	16	16	100	22	20	TC.. 16T3..	0,200	1335	5516	3414	1750
STFC R/L 2020 K16	20	20	125	22	25	TC.. 16T3..	0,400	1335	5516	3414	1750
STFC R/L 2525 M16	25	25	150	28	32	TC.. 16T3..	0,700	1335	5516	3414	1750

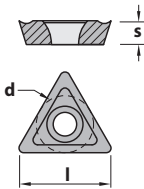

TC..	l	s	d
TC.. 0902..	9,62	2,38	5,55
TC.. 1102..	11,00	2,38	6,35
TC.. 16T3..	16,50	3,97	9,52

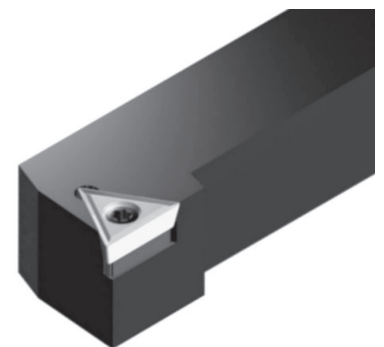
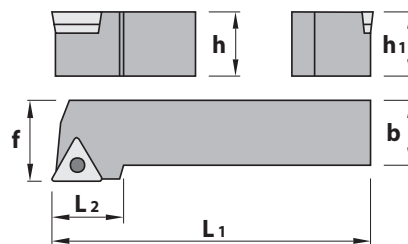
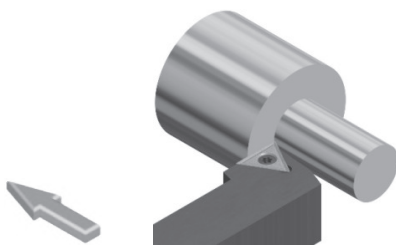

General angle 90°
Главный угол в плане 90°

STGC

	h=h ₁	b	L ₁	L ₂	f	Plates					
STGC R/L 0808 D09	8	8	60	12	10	TC.. 0902..	0,050	1222	5506	-	-
STGC R/L 1010 E09	10	10	70	14	12	TC.. 0902..	0,070	1222	5506	-	-
STGC R/L 1212 F11	12	12	80	16	16	TC.. 1102..	0,100	1225	5507	-	-
STGC R/L 1616 H11	16	16	100	18	20	TC.. 1102..	0,200	1225	5507	-	-
STGC R/L 1212 F16	12	12	80	18	16	TC.. 16T3..	0,100	1240	5515	-	-
STGC R/L 1616 H16	16	16	100	18	20	TC.. 16T3..	0,200	1335	5516	3414	1750
STGC R/L 2020 K16	20	20	125	22	25	TC.. 16T3..	0,400	1335	5516	3414	1750
STGC R/L 2525 M16	25	25	150	28	32	TC.. 16T3..	0,700	1335	5516	3414	1750

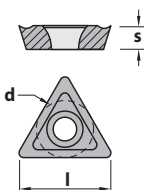

TC..	l	s	d
TC.. 0902..	9,62	2,38	5,55
TC.. 1102..	11,00	2,38	6,35
TC.. 16T3..	16,50	3,97	9,52



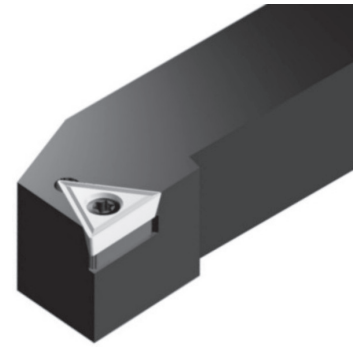
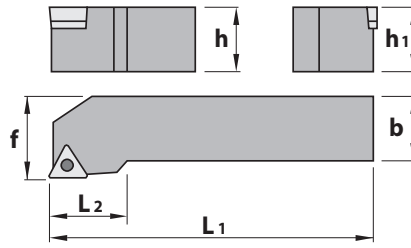
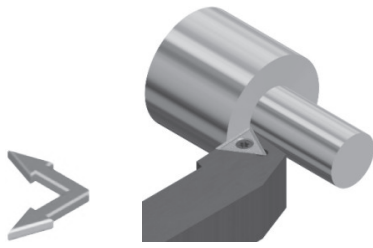

General angle 93°
Главный угол в плане 93°

STJC

	h=h ₁	b	L ₁	L ₂	f	Plates					
STJC R/L 0808 D09	8	8	60	12	10	TC.. 0902..	0,050	1222	5506	-	-
STJC R/L 1010 E09	10	10	70	14	12	TC.. 0902..	0,070	1222	5506	-	-
STJC R/L 1212 F11	12	12	80	16	16	TC.. 1102..	0,100	1225	5507	-	-
STJC R/L 1616 H11	16	16	100	18	20	TC.. 1102..	0,200	1225	5507	-	-
STJC R/L 1212 F16	12	12	80	18	16	TC.. 16T3..	0,100	1240	5515	-	-
STJC R/L 1616 H16	16	16	100	18	20	TC.. 16T3..	0,200	1335	5516	3414	1750
STJC R/L 2020 K16	20	20	125	22	25	TC.. 16T3..	0,400	1335	5516	3414	1750
STJC R/L 2525 M16	25	25	150	28	32	TC.. 16T3..	0,700	1335	5516	3414	1750

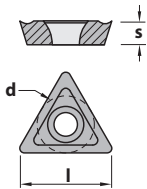

TC..	l	s	d	TCGT	TCMT	TCMW
TC.. 0902..	9,62	2,38	5,55			
TC.. 1102..	11,00	2,38	6,35			
TC.. 16T3..	16,50	3,97	9,52			

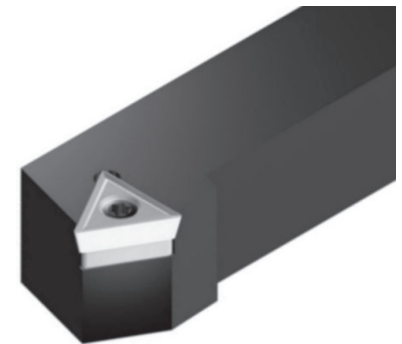
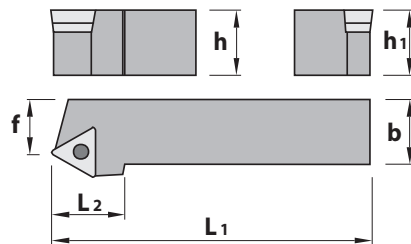
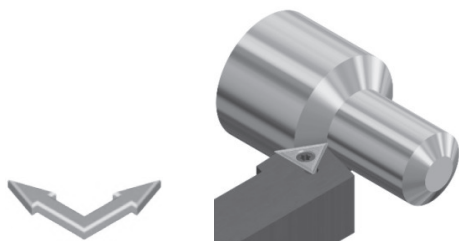

General angle 60°
Главный угол в плане 60°

STTC

	h=h ₁	b	L ₁	L ₂	f	Plates					
STTC R/L 0808 D09	8	8	60	12	7	TC.. 0902..	0,050	1222	5506	-	-
STTC R/L 1010 E09	10	10	70	14	9	TC.. 0902..	0,070	1222	5506	-	-
STTC R/L 1212 F11	12	12	80	16	11	TC.. 1102..	0,100	1225	5507	-	-
STTC R/L 1616 H11	16	16	100	18	13	TC.. 1102..	0,200	1225	5507	-	-
STTC R/L 1212 F16	12	12	80	18	11	TC.. 16T3..	0,100	1240	5515	-	-
STTC R/L 1616 H16	16	16	100	18	13	TC.. 16T3..	0,200	1335	5516	3414	1750
STTC R/L 2020 K16	20	20	125	22	17	TC.. 16T3..	0,400	1335	5516	3414	1750
STTC R/L 2525 M16	25	25	150	28	22	TC.. 16T3..	0,700	1335	5516	3414	1750

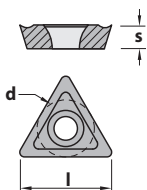

TC..	l	s	d	TCGT	TCMT	TCMW
TC.. 0902..	9,62	2,38	5,55			
TC.. 1102..	11,00	2,38	6,35			
TC.. 16T3..	16,50	3,97	9,52			

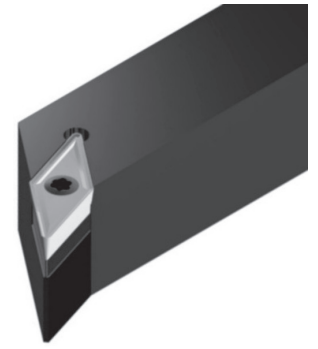
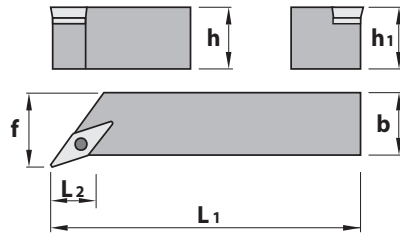
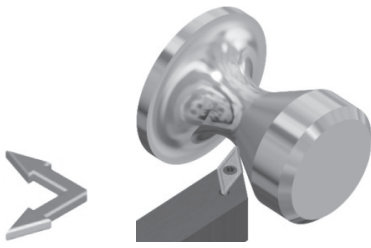

General angle 93°
Главный угол в плане 93°

SVHC

	h=h ₁	b	L ₁	L ₂	f	Plates					
SVHC R/L 2020 K16	20	20	125	28	25	VC.. 1604..	0,400	1335	5516	3718	1750
SVHC R/L 2525 M16	25	25	150	28	32	VC.. 1604..	0,700	1335	5516	3718	1750
SVHC R/L 3225 P16	32	25	170	34	32	VC.. 1604..	0,900	1335	5516	3718	1750
SVHC R/L 2525 M22	25	25	150	28	32	VC.. 2205..	0,700	1540	5520	3722	1760
SVHC R/L 3225 P22	32	25	170	34	32	VC.. 2205..	0,900	1540	5520	3722	1760

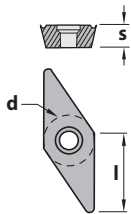

VC..	l	s	d
VC.. 1604..	16,50	4,76	9,52
VC.. 2205..	22,10	5,56	12,70

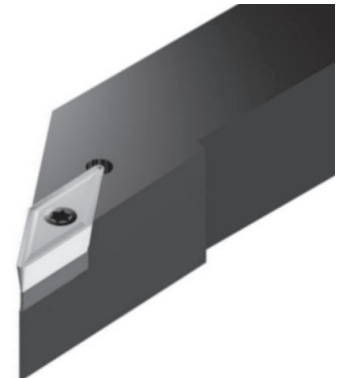
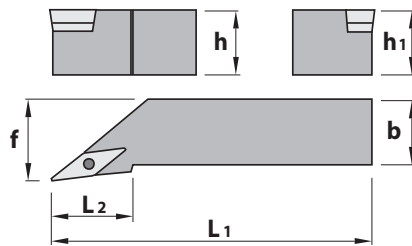
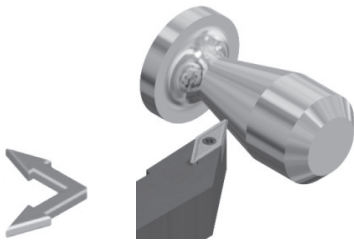

General angle 93°
Главный угол в плане 93°

SVJB

	h=h ₁	b	L ₁	L ₂	f	Plates					
SVJB R/L 2020 K16	20	20	125	34	25	VBMT 1604..	0,400	1335	5516	3718	1750
SVJB R/L 2525 M16	25	25	150	34	32	VBMT 1604..	0,700	1335	5516	3718	1750
SVJB R/L 3225 P16	32	25	170	38	32	VBMT 1604..	0,900	1335	5516	3718	1750

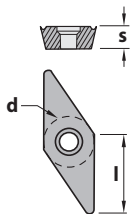

VBMT	l	s	d
VBMT 1604..	16,50	4,76	9,52

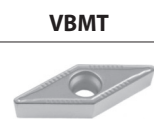

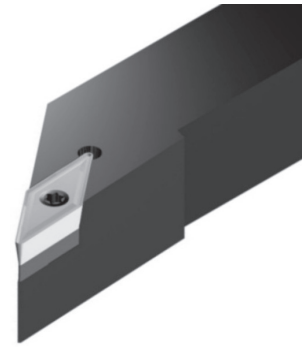
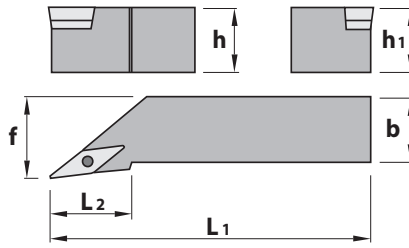
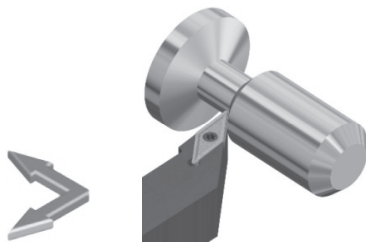

General angle 93°
Главный угол в плане 93°

SVJC

		h=h ₁	b	L ₁	L ₂	f	Plates					
SVJC	R/L 1212 F11	12	12	80	20	16	VC.. 1103..	0,100	1225	5507	-	-
SVJC	R/L 1616 H11	16	16	100	25	20	VC.. 1103..	0,200	1225	5507	-	-
SVJC	R/L 2020 K11	20	20	125	28	25	VC.. 1103..	0,400	1225	5507	-	-
SVJC	R/L 2020 K16	20	20	125	34	25	VC.. 1604..	0,400	1335	5516	3718	1750
SVJC	R/L 2525 M16	25	25	150	34	32	VC.. 1604..	0,700	1335	5516	3718	1750
SVJC	R/L 3225 P16	32	25	170	34	32	VC.. 1604..	0,900	1335	5516	3718	1750

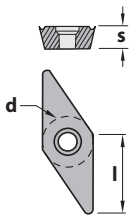

VC..	l	s	d	VCGT	VCMT
VC.. 1103..	11,00	3,18	6,35		
VC.. 1604..	16,50	4,76	9,52		

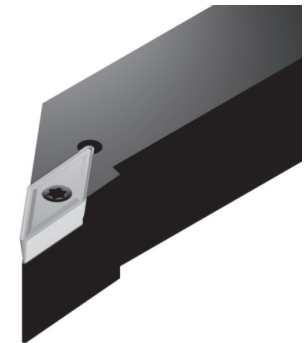
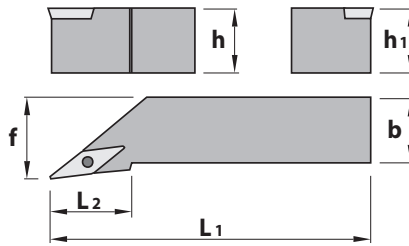
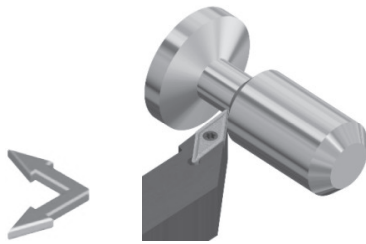

General angle 95°
Главный угол в плане 95°

SVLC

		h=h ₁	b	L ₁	L ₂	f	Plates			
SVLC	R/L 1212 G13	12	12	90	25	16	VCMT 1303..	0,100	1230	5508
SVLC	R/L 1616 H13	16	16	100	25	20	VCMT 1303..	0,200	1230	5508
SVLC	R/L 2020 K13	20	20	125	28	25	VCMT 1303..	0,400	1230	5508
SVLC	R/L 2525 M13	25	25	150	28	32	VCMT 1303..	0,700	1230	5508

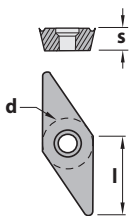

VCMT	l	s	d	VCMT
VC.. 1303..	13,00	3,18	8,00	

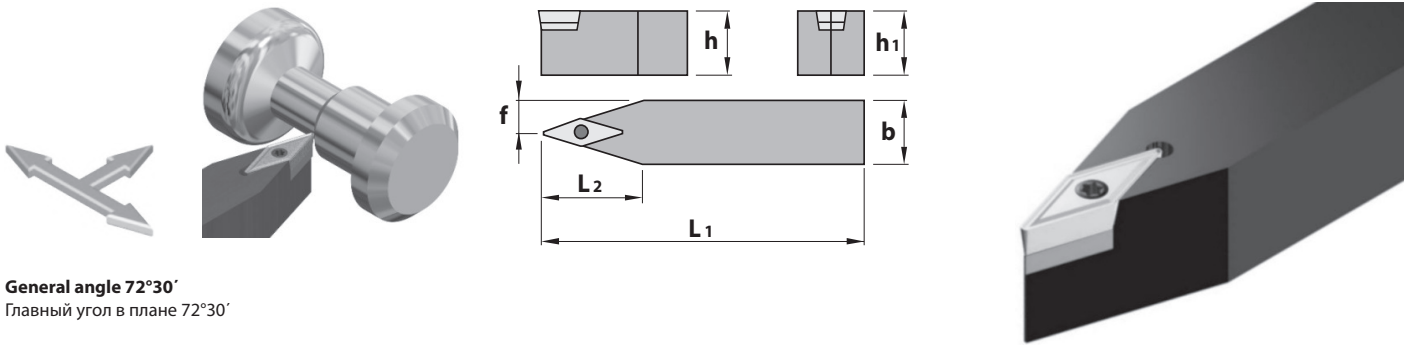

General angle 72°30'
Главный угол в плане 72°30'

SVVB

	h=h ₁	b	L ₁	L ₂	f	Plates					
SVVB N 2020 K16	20	20	125	37	10,6	VBMT 1604..	0,400	1335	5516	3718	1750
SVVB N 2525 M16	25	25	150	37	13,1	VBMT 1604..	0,700	1335	5516	3718	1750
SVVB N 3225 P16	32	25	170	37	13,1	VBMT 1604..	0,900	1335	5516	3718	1750

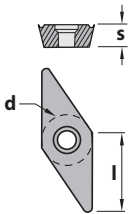

VBMT	l	s	d	VBMT
VBMT 1604..	16,50	4,76	9,52	

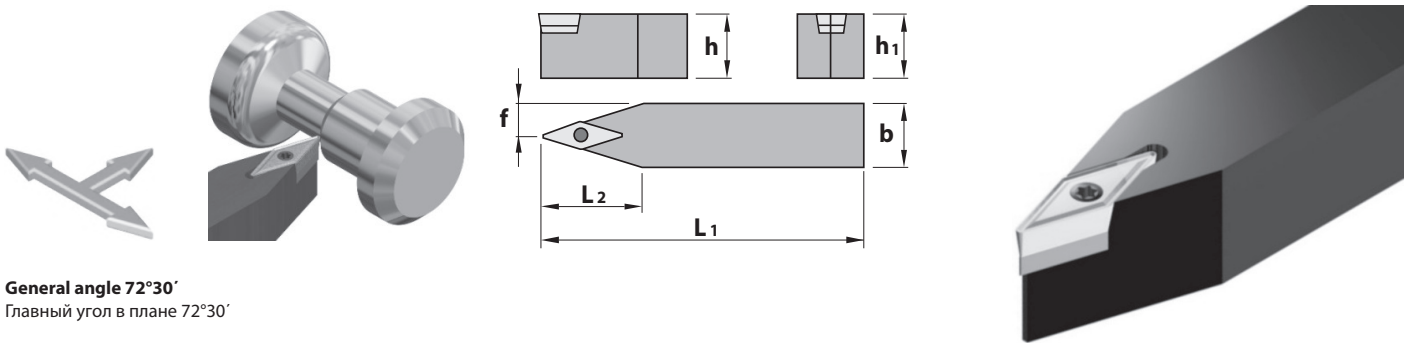

General angle 72°30'
Главный угол в плане 72°30'

SVVC

	h=h ₁	b	L ₁	L ₂	f	Plates					
SVVC N 1212 F11	12	12	80	25	6,6	VC.. 1103..	0,100	1225	5507	-	-
SVVC N 1616 H11	16	16	100	25	8,6	VC.. 1103..	0,200	1225	5507	-	-
SVVC N 2020 K11	20	20	125	25	10,6	VC.. 1103..	0,400	1225	5507	-	-
SVVC N 2020 K16	20	20	125	37	10,6	VC.. 1604..	0,400	1335	5516	3718	1750
SVVC N 2525 M16	25	25	150	37	13,1	VC.. 1604..	0,700	1335	5516	3718	1750
SVVC N 3225 P16	32	25	170	37	13,1	VC.. 1604..	0,900	1335	5516	3718	1750

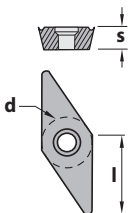

VC..	l	s	d	VCGT	VCMT
VC.. 1103..	11,00	3,18	6,35		
VC.. 1604..	16,50	4,76	9,52		



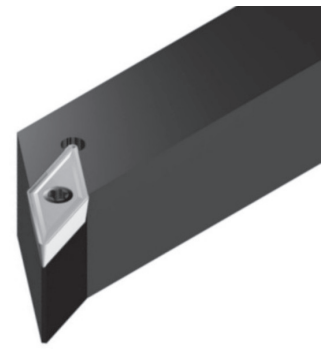
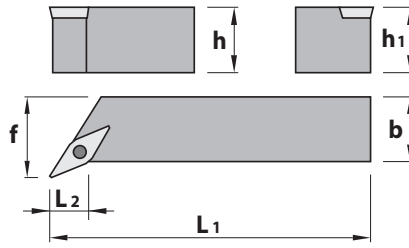
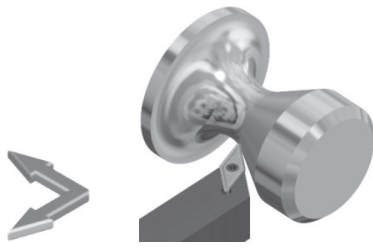

General angle 113°
Главный угол в плане 113°

SVXC

	h=h ₁	b	L ₁	L ₂	f	Plates			
SVXC R/L 1212 G13	12	12	90	11,5	16	VCMT 1303..	0,100	1230	5508
SVXC R/L 1616 H13	16	16	100	13,8	20	VCMT 1303..	0,200	1230	5508
SVXC R/L 2020 K13	20	20	125	28,0	25	VCMT 1303..	0,400	1230	5508
SVXC R/L 2525 M13	25	25	150	28,0	32	VCMT 1303..	0,700	1230	5508

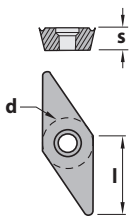

VCMT	l	s	d	VCMT
VC.. 1303..	13,00	3,18	8,00	

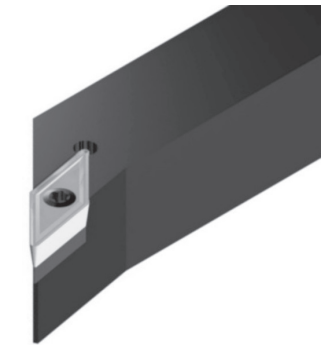
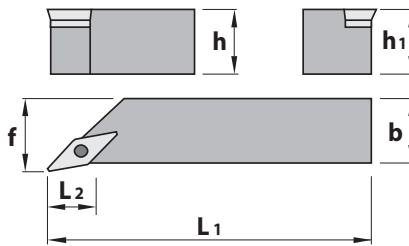
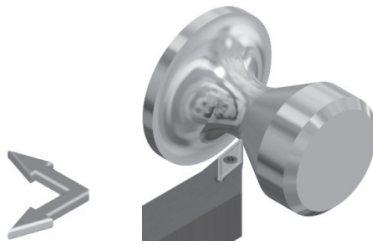

General angle 100°
Главный угол в плане 100°

SVZC

	h=h ₁	b	L ₁	L ₂	f	Plates					
SVZC R/L 2020 K16	20	20	125	28	25	VC.. 1604..	0,400	1335	5516	3718	1750
SVZC R/L 2525 M16	25	25	150	34	32	VC.. 1604..	0,700	1335	5516	3718	1750
SVZC R/L 3225 P16	32	25	170	34	32	VC.. 1604..	0,900	1335	5516	3718	1750

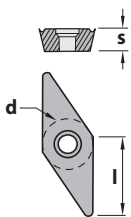

VC..	l	s	d	VCGT	VCMT
VC.. 1604..	16,50	4,76	9,52		

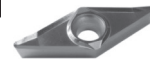

6

TOOLS WITH CARBIDE INSERTS
ИНСТРУМЕНТ СО СМЕННЫМИ ТВЕРДОСПЛАВНЫМИ ПЛАСТИНАМИ

INTERNAL TOOLHOLDERS
ТОКАРНЫЕ ДЕРЖАВКИ ДЛЯ
ВНУТРЕННЕЙ ОБРАБОТКИ

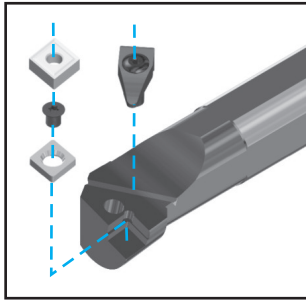

«D» Dimple lock

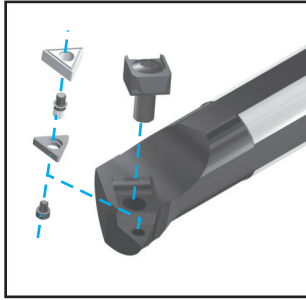
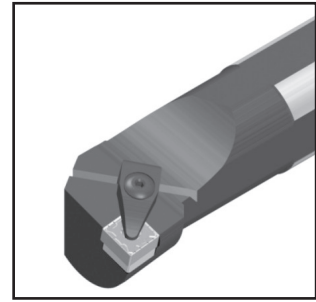

«M» Wedge clamp

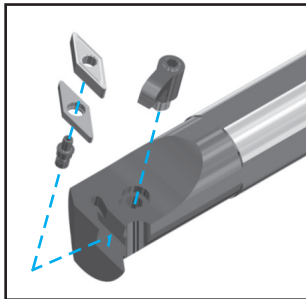
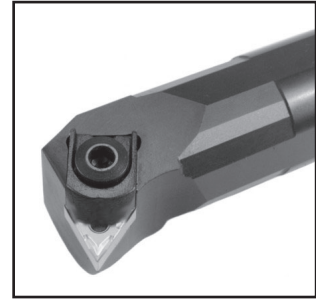

«M-K» Double lock

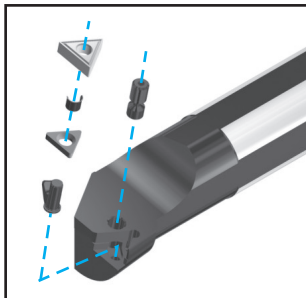
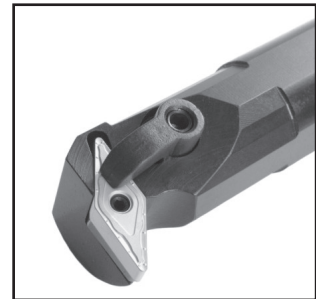

«P» Lever lock

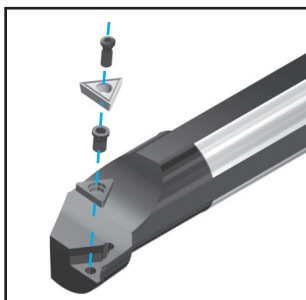

«S» Screw lock



S **25** **T** **S** **D** **U** **C** **R** **11** - **EX**

1 2 3 4 5 6 7 8 9 10

1

Type of holder			
A	With internal coolant		
H	Anti-vibration shank		
E	Anti-vibration shank with internal coolant		
S	Steel shank		

2

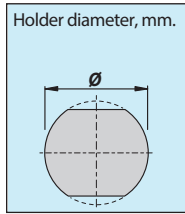

3

Holder length, mm.

H	100	T	300
J	110	U	350
K	125	V	400
L	140	W	450
M	150	Y	500
Q	180	X	Special
R	200		
S	250		

4

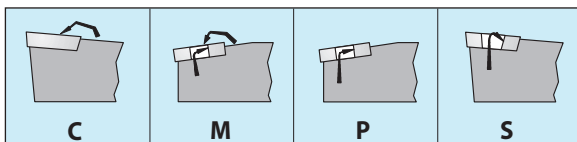

6

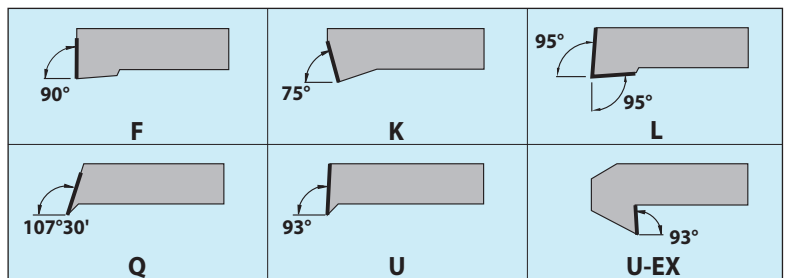

5

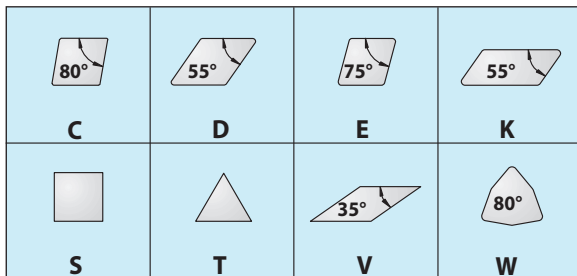

7

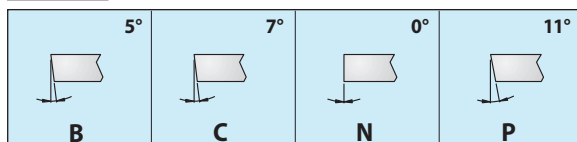

8

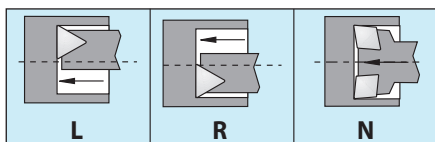



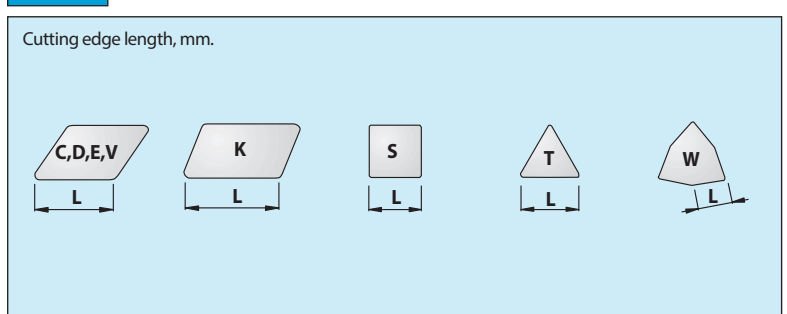

9





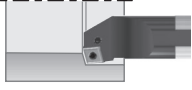
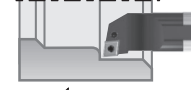
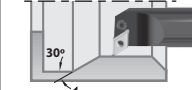
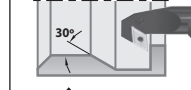



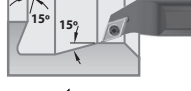

10

Additional manufacturer options

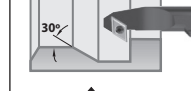
Lever lock / Рычажный прижим

<p>PCKN 75°</p>  <p>Page 128</p> <p>CN.. 1204.. CN.. 1606.. CN.. 1906..</p>	<p>PCLN 95°</p>  <p>Page 128</p> <p>CN.. 0903.. CN.. 1204.. CN.. 1606.. CN.. 1906..</p>	<p>PDUN 93°</p>  <p>Page 129</p> <p>DN.. 1104.. DN.. 1506..</p>	<p>PDUN 93°-EX</p>  <p>Page 129</p> <p>DN.. 1506..</p>	<p>PSKN 75°</p>  <p>Page 130</p> <p>SNM.. 1204.. SNM.. 1906..</p>	<p>PSSN 45°</p>  <p>Page 130</p> <p>SNM.. 1204..</p>
<p>PTFN 90°</p>  <p>Page 131</p> <p>TNM.. 1604.. TNM.. 2204..</p>	<p>PWLN 95°</p>  <p>Page 132</p> <p>WNM.. 0604.. WNM.. 0804..</p>				

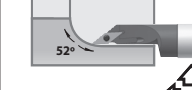
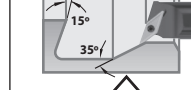
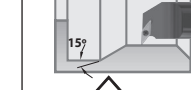
Screw lock / Винтовой прижим

<p>SCLC 95°</p>  <p>Page 133</p> <p>CC.. 0602.. CC.. 09T3.. CC.. 1204..</p>	<p>SDQC 107°30'</p>  <p>Page 134</p> <p>DC.. 0702.. DC.. 11T3..</p>	<p>SDUC 93°</p>  <p>Page 135</p> <p>DC.. 0702.. DC.. 11T3..</p>	<p>SDUC 93°-EX</p>  <p>Page 136</p> <p>DC.. 0702.. DC.. 11T3..</p>	<p>SSKC 75°</p>  <p>Page 137</p> <p>SC.. 09T3.. SC.. 1204..</p>	
<p>STFC 90°</p>  <p>стр. 138</p> <p>TC.. 0902.. TC.. 1102.. TC.. 16T3..</p>	<p>STUC 93°</p>  <p>Page 139</p> <p>TC.. 1102.. TC.. 16T3..</p>	<p>SVJC 52°</p>  <p>Page 139</p> <p>VC.. 1103.. VC.. 1604..</p>	<p>SVQC 107°30'</p>  <p>Page 140</p> <p>VC.. 1103.. VC.. 1303.. VC.. 1604..</p>	<p>SVUB 93°</p>  <p>Page 140</p> <p>VBMT 1604..</p>	<p>SVUC 93°</p>  <p>Page 141</p> <p>VC.. 1103.. VC.. 1604..</p>

Dimple lock (on request) / Двойной прижим (по запросу)

DCLN 95°

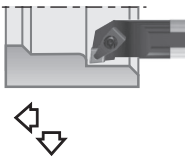

CN.. 1204..

DDUN 93°

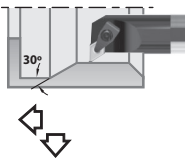

DN.. 1506..

Toolholders with wedge and double clamping (on request) / Державки с клиновым и двойным зажимом (по запросу)

MCLN-K 95°

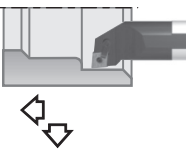

CN.. 1204..

MDUN-K 93°

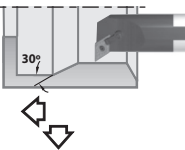

DN.. 1506..

MSKN-K 75°

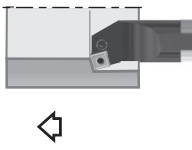

SNM.. 1204..

MTFN 90°

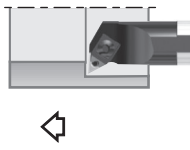
TNM.. 1604..
TNM.. 2204..

MTFN-K 90°

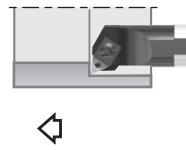

TNM.. 1604..

MTUN 93°

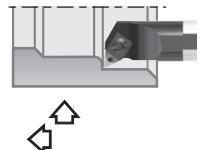
TNM.. 1604..
TNM.. 2204..

MVUN-K 93°

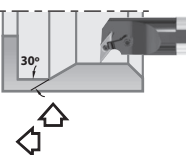

VN.. 1604..

MWLN 95°

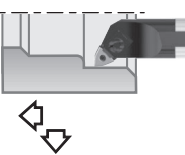
WNM.. 0604..
WNM.. 0804..

MWLN-K 95°

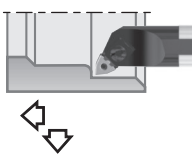

WNM.. 0804..

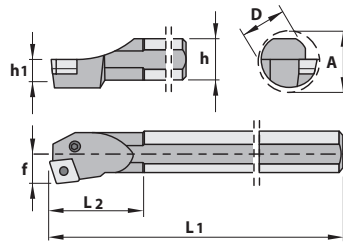
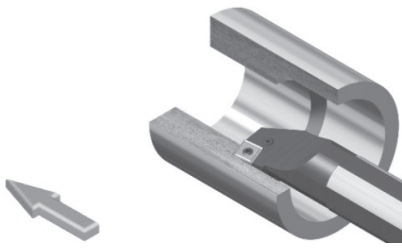

General angle 75°
Главный угол в плане 75°

PCKN

	D	h	h1	L1	L2	f	A	Plates							
S25T PCKN R/L 12	25	23	11,5	300	40	17	31	CN.. 1204..	0,700	8212	1626	5025	-	-	-
S32U PCKN R/L 12	32	30	15,0	350	50	22	39	CN.. 1204..	2,050	8312	1648	5003	3612	4112	0012
S40V PCKN R/L 12	40	37	18,5	400	60	27	48	CN.. 1204..	3,750	8012	1608	5003	3612	4112	0012
S50W PCKN R/L 16	50	47	23,5	450	65	35	61	CN.. 1606..	6,500	8016	1618	5003	3616	4115	0015
S50W PCKN R/L 19	50	47	23,5	450	65	35	61	CN.. 1906..	6,500	8219	1610	5004	3619	4119	0019

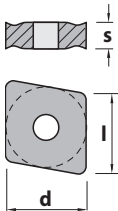

CN..	l	s	d	CNGP	CNMA	CNMG	CNMM
CN.. 1204..	12,90	4,76	12,70				
CN.. 1606..	16,10	6,35	15,88				
CN.. 1906..	19,30	6,35	19,05				

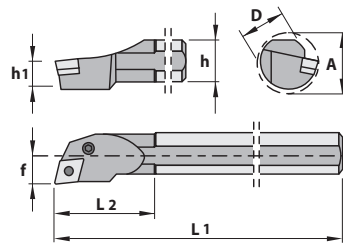
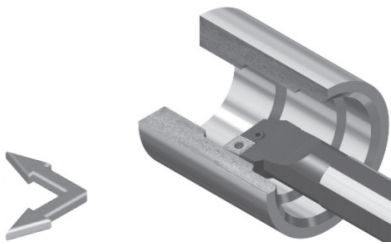

General angle 95°
Главный угол в плане 95°

PCLN

	D	h	h1	L1	L2	f	A	Plates							
S16R PCLN R/L 09	16	15	7,5	200	26	11	20	CN.. 0903..	0,300	8005	1605	5002	-	-	-
S20S PCLN R/L 09	20	18	9,0	250	29	13	25	CN.. 0903..	0,550	8005	1605	5002	-	-	-
S25T PCLN R/L 09	25	23	11,5	300	33	17	32	CN.. 0903..	0,700	8009	1626	5025	3609	4109	0009
S25T PCLN R/L 12	25	23	11,5	300	40	17	31	CN.. 1204..	0,700	8212	1626	5025	-	-	-
S32U PCLN R/L 12	32	30	15,0	350	50	22	39	CN.. 1204..	2,050	8312	1648	5003	3612	4112	0012
S40V PCLN R/L 12	40	37	18,5	400	60	27	48	CN.. 1204..	3,750	8012	1608	5003	3612	4112	0012
S50W PCLN R/L 12	50	47	23,5	450	65	35	61	CN.. 1204..	6,500	8012	1608	5003	3612	4112	0012
S50W PCLN R/L 16	50	47	23,5	450	65	35	61	CN.. 1606..	6,500	8016	1618	5003	3616	4115	0015
S50W PCLN R/L 19	50	47	23,5	450	65	35	61	CN.. 1906..	6,500	8219	1610	5004	3619	4129	0019

With internal coolant

A-PCLN

	D	h	h1	L1	L2	f	A	Plates							
A16M PCLN R/L 09	16	15	7,5	150	26	11	20	CN.. 0903..	0,200	8005	1605	5002	-	-	-
A20Q PCLN R/L 09	20	18	9,0	180	29	13	25	CN.. 0903..	0,400	8005	1605	5002	-	-	-
A25R PCLN R/L 12	25	23	11,5	200	40	17	31	CN.. 1204..	0,700	8212	1626	5025	-	-	-
A32S PCLN R/L 12	32	30	15,0	250	50	22	39	CN.. 1204..	1,400	8312	1648	5003	3612	4112	0012
A40T PCLN R/L 12	40	37	18,5	300	60	27	48	CN.. 1204..	2,650	8012	1608	5003	3612	4112	0012

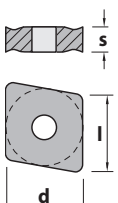

CN..	l	s	d	CNGP	CNMA	CNMG	CNMM
CN.. 0903..	9,65	3,18	9,52				
CN.. 1204..	12,90	4,76	12,70				
CN.. 1606..	16,10	6,35	15,88				
CN.. 1906..	19,30	6,35	19,05				

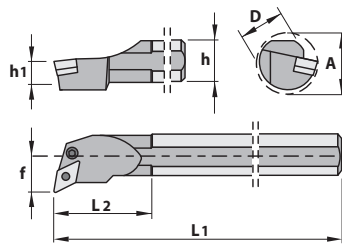
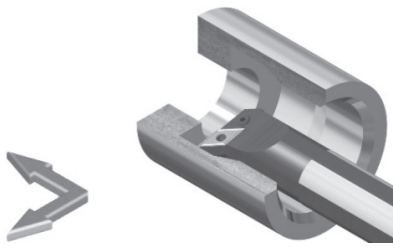

General angle 93°
Главный угол в плане 93°

PDUN

	D	h	h1	L1	L2	f	A	Plates											
S25T PDUN R/L 11	25	23	11,5	300	35	17	32	DN.. 1104..	0,700	8009	1606	5025	3711	4109	0009	-	-	-	-
S32U PDUN R/L 11	32	30	15,0	350	40	22	40	DN.. 1104..	2,050	8009	1606	5025	3711	4109	0009	-	-	-	-
S32U PDUN R/L 15	32	30	15,0	350	50	22	39	DN.. 1506..	2,050	8415	1648	5003	3715	4112	0012	3725	4135	-	-
S40V PDUN R/L 15	40	37	18,5	400	60	27	48	DN.. 1506..	3,750	8415	1638	5003	3715	4112	0012	3725	4135	-	-
S50W PDUN R/L 15	50	47	23,5	450	65	35	61	DN.. 1506..	6,500	8415	1638	5003	3715	4112	0012	3725	4135	-	-

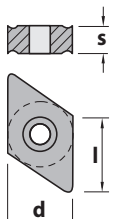

DN..	l	s	d	DNGP	DNMA	DNMG
DN.. 1104..	11,60	4,76	9,52			
DN.. 1504..	15,50	4,76	12,70			
DN.. 1506..	15,50	6,35	12,70			

With internal coolant

A-PDUN

	D	h	h1	L1	L2	f	A	Plates											
A25R PDUN R/L 11	25	23	11,5	200	40	17	31	DN.. 1104..	0,700	8009	1606	5025	3711	4109	0009	-	-	-	-
A32S PDUN R/L 15	32	30	15,0	250	50	22	39	DN.. 1506..	1,400	8415	1648	5003	3715	4112	0012	3725	4135	-	-
A40T PDUN R/L 15	40	37	18,5	300	60	27	48	DN.. 1506..	2,650	8415	1638	5003	3715	4112	0012	3725	4135	-	-

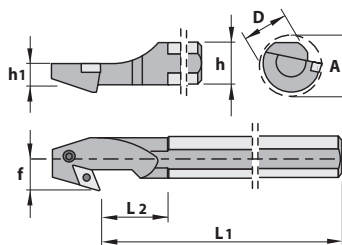
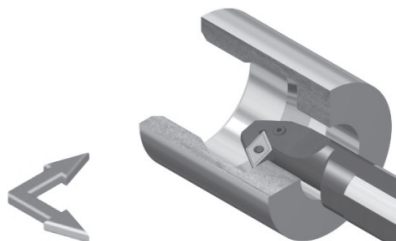

General angle 93°
Главный угол в плане 93°

PDUN

	D	h	h1	L1	L2	f	A	Plates											
S32U PDUN R/L 15-EX	32	30	15,0	350	50	22	39	DN.. 1506..	2,050	8415	1648	5003	-	-	-	-	-	-	-
S40V PDUN R/L 15-EX	40	37	18,5	400	60	27	48	DN.. 1506..	3,750	8415	1638	5003	3715	4112	0012	3725	4135	-	-
S50W PDUN R/L 15-EX	50	47	23,5	450	65	35	61	DN.. 1506..	6,500	8415	1638	5003	3715	4112	0012	3725	4135	-	-

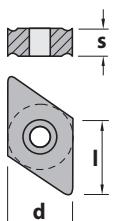

DN..	l	s	d	DNGP	DNMA	DNMG
DN.. 1504..	15,50	4,76	12,70			
DN.. 1506..	15,50	6,35	12,70			

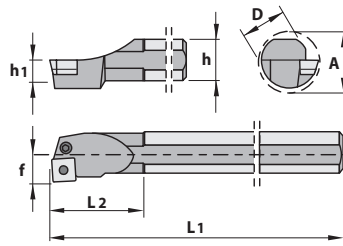
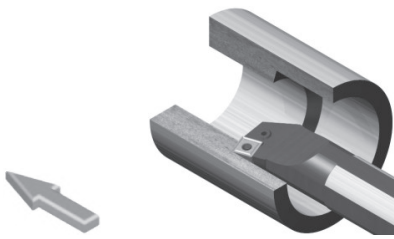

General angle 75°
Главный угол в плане 75°

PSKN

	D	h	h1	L1	L2	f	A	Plates							
S25T PSKN R/L 12	25	23	11,5	300	40	17	31	SNM.. 1204..	0,700	8212	1626	5025	-	-	-
S32U PSKN R/L 12	32	30	15,0	350	50	22	39	SNM.. 1204..	2,050	8312	1648	5003	3512	4112	0012
S40V PSKN R/L 12	40	37	18,5	400	60	27	48	SNM.. 1204..	3,750	8012	1608	5003	3512	4112	0012
S50W PSKN R/L 19	50	47	23,5	450	65	35	61	SNM.. 1906..	6,500	8219	1710	5004	3519	4129	0019

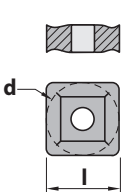

SNM..	l	s	d	SNMA	SNMG	SNMM
SNM.. 1204..	12,70	4,76	12,70			
SNM.. 1906..	19,05	6,35	19,05			

With internal coolant
Расточные державки с внутренним подводом СОЖ

A-PSKN

	D	h	h1	L1	L2	f	A	Plates							
A25R PSKN R/L 12	25	23	11,5	200	40	17	31	SNM.. 1204..	0,700	8212	1626	5025	-	-	-
A32S PSKN R/L 12	32	30	15,0	250	50	22	39	SNM.. 1204..	1,400	8312	1648	5003	3512	4112	0012
A40T PSKN R/L 12	40	37	18,5	300	60	27	48	SNM.. 1204..	2,650	8012	1608	5003	3512	4112	0012

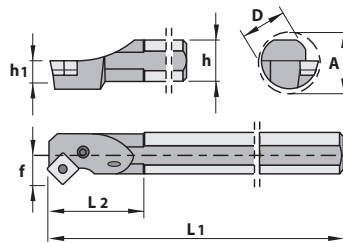
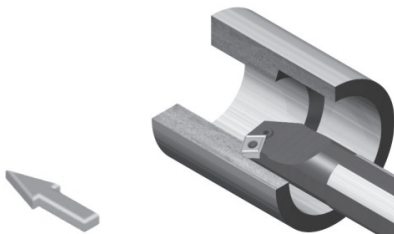

General angle 45°
Главный угол в плане 45°

With internal coolant
Расточные державки с внутренним подводом СОЖ

A-PSSN

	D	h	h1	L1	L2	f	A	Plates							
A25R PSSN R/L 12	25	23	11,5	200	40	17	31	SNM.. 1204..	0,700	8212	1626	5025	-	-	-
A32S PSSN R/L 12	32	30	15,0	250	50	22	39	SNM.. 1204..	2,050	8312	1648	5003	3512	4112	0012

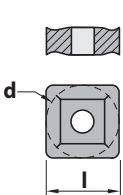

SNM..	l	s	d	SNMA	SNMG	SNMM
SNM.. 1204..	12,70	4,76	12,70			

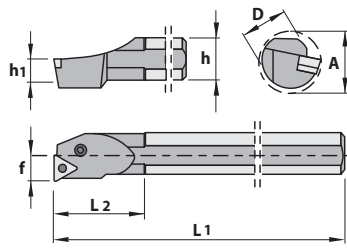
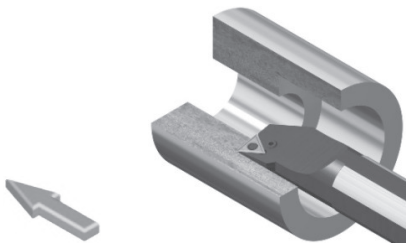

General angle 90°
Главный угол в плане 90°

Boring holders

PTFN

	D	h	h1	L1	L2	f	A	Plates							
S25T PTFN R/L 16	25	23	11,5	300	40	17	31	TNM.. 1604..	0,700	8216	1605	5002	-	-	-
S32U PTFN R/L 16	32	30	15,0	350	50	22	39	TNM.. 1604..	2,050	8009	1606	5025	3416	4109	0009
S40V PTFN R/L 22	40	37	18,5	400	60	27	48	TNM.. 2204..	3,750	8012	1608	5003	3422	4112	0012
S50W PTFN R/L 22	50	47	23,5	450	65	35	61	TNM.. 2204..	6,500	8012	1608	5003	3422	4112	0012

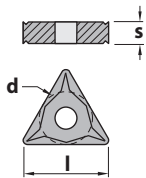

TNM..	l	s	d	TNMA	TNMG
TNM.. 1604..	16,50	4,76	9,52		
TNM.. 2204..	22,00	4,76	12,70		

With internal coolant
Расточные державки с внутренним подводом СОЖ

A-PTFN

	D	h	h1	L1	L2	f	A	Plates							
A25R PTFN R/L 16	25	23	11,5	200	40	17	31	TNM.. 1604..	0,700	8216	1605	5002	-	-	-
A32S PTFN R/L 16	32	30	15,0	250	50	22	39	TNM.. 1604..	1,400	8009	1606	5025	3416	4109	0009
A40T PTFN R/L 22	40	37	18,5	300	60	27	48	TNM.. 2204..	2,650	8012	1608	5003	3422	4112	0012

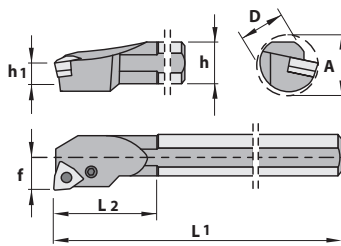
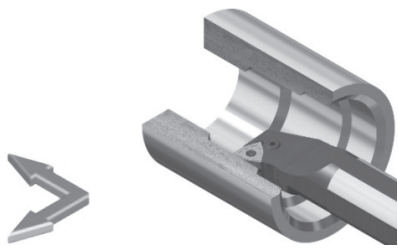

General angle 95°

Главный угол в плане 95°

Boring holders

PWLN

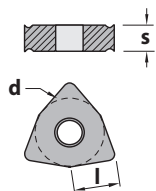
	D	h	h ₁	L ₁	L ₂	f	A	Plates							
S16R PWLN R/L 06	16	15	7,5	200	24	11	20	WNM..0604..	0,300	8216	1605	5002	-	-	-
S20S PWLN R/L 06	20	18	9,0	250	36	13	27	WNM..0604..	0,550	8216	1605	5002	-	-	-
S25T PWLN R/L 06	25	23	11,5	300	40	17	31	WNM..0604..	0,700	8009	1606	5025	3007	4109	0009
S25T PWLN R/L 08	25	23	11,5	300	40	17	31	WNM..0804..	0,700	8212	1626	5025	-	-	-
S32U PWLN R/L 08	32	30	15,0	350	50	22	39	WNM..0804..	2,050	8012	1608	5003	3008	4112	0012
S40V PWLN R/L 08	40	37	18,5	400	60	27	48	WNM..0804..	3,750	8012	1608	5003	3008	4112	0012



WNM..	l	s	d	WNMA	WNMG
WNM..0604..	6,45	4,76	9,52		
WNM..0804..	8,14	4,76	12,70		

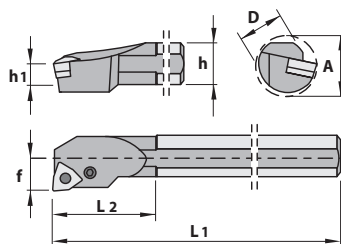
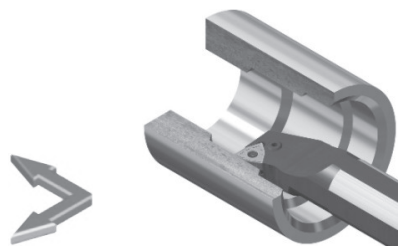

General angle 95°

Главный угол в плане 95°

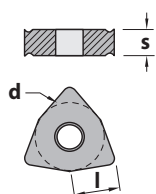

With internal coolant
Расточные державки
с внутренним подводом СОЖ

A-PWLN

	D	h	h ₁	L ₁	L ₂	f	A	Plates							
A16M PWLN R/L 06	16	15	7,5	150	24	11	20	WNM..0604..	0,200	8216	1605	5002	-	-	-
A20Q PWLN R/L 06	20	18	9,0	180	36	13	27	WNM..0604..	0,400	8216	1605	5002	-	-	-
A25R PWLN R/L 06	25	23	11,5	200	40	17	31	WNM..0604..	0,700	8009	1606	5025	3007	4109	0009
A32S PWLN R/L 06	32	30	15,0	250	50	22	39	WNM..0604..	1,400	8009	1606	5025	3007	4109	0009
A25R PWLN R/L 08	25	23	11,5	200	40	17	31	WNM..0804..	0,700	8212	1626	5025	-	-	-
A32S PWLN R/L 08	32	30	15,0	250	50	22	39	WNM..0804..	1,400	8012	1608	5003	3008	4112	0012
A40T PWLN R/L 08	40	37	18,5	300	60	27	48	WNM..0804..	2,650	8012	1608	5003	3008	4112	0012

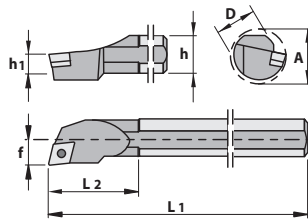
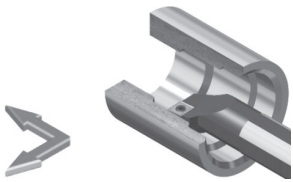

WNM..	l	s	d	WNMA	WNMG
WNM..0604..	6,45	4,76	9,52		
WNM..0804..	8,14	4,76	12,70		



General angle 95°
Главный угол в плане 95°

Boring holders with steel shank

SCLC

	D	h	h1	L1	L2	f	A	Plates	kg					
S08K SCLC R/L 06	8	7	3,5	125	16	5	11	CC.. 0602..	0,040	1425	5507	-	-	
S10M SCLC R/L 06	10	9	4,5	150	25	7	13	CC.. 0602..	0,060	1425	5507	-	-	
S12M SCLC R/L 06	12	11	5,5	150	25	9	16	CC.. 0602..	0,150	1425	5507	-	-	
S12M SCLC R/L 09	12	11	5,5	150	25	9	16	CC.. 09T3..	0,150	1440	5515	-	-	
S12Q SCLC R/L 09	12	11	5,5	180	25	9	16	CC.. 09T3..	0,150	1440	5515	-	-	
S16R SCLC R/L 09	16	15	7,5	200	30	11	20	CC.. 09T3..	0,300	1440	5515	-	-	
S20S SCLC R/L 09	20	18	9,0	250	35	13	24	CC.. 09T3..	0,550	1440	5515	-	-	
S25T SCLC R/L 09	25	23	11,5	300	40	17	31	CC.. 09T3..	0,550	1240	5515	-	-	
S20S SCLC R/L 12	20	18	9,0	250	35	13	24	CC.. 1204..	0,550	1250	5520	-	-	
S25T SCLC R/L 12	25	23	11,5	300	40	17	31	CC.. 1204..	0,700	1250	5520	-	-	
S32U SCLC R/L 12	32	30	15,0	350	50	22	39	CC.. 1204..	2,050	1540	5517	3614	1760	
S40V SCLC R/L 12	40	37	18,5	400	60	27	48	CC.. 1204..	3,750	1540	5517	3614	1760	
S50W SCLC R/L 12	50	47	23,5	450	65	35	61	CC.. 1204..	6,500	1540	5517	3614	1760	

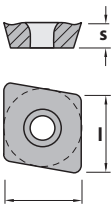

CC..	l	s	d	CCGT	CCMT	CCMW
CC.. 0602..	6,45	2,38	6,35			
CC.. 09T3..	9,65	3,97	9,52			
CC.. 1204..	12,90	4,76	12,70			

With internal coolant
Расточные державки с внутренним подводом СОЖ

A-SCLC

	D	h	h1	L1	L2	f	A	Plates	kg					
A08F SCLC R/L 06	8	7	3,5	80	16	5	11	CC.. 0602..	0,030	1425	5507	-	-	
A10H SCLC R/L 06	10	9	4,5	100	25	7	13	CC.. 0602..	0,040	1425	5507	-	-	
A12K SCLC R/L 06	12	11	5,5	125	25	9	16	CC.. 0602..	0,100	1425	5507	-	-	
A16M SCLC R/L 09	16	15	7,5	150	30	11	20	CC.. 09T3..	0,200	1440	5515	-	-	
A20Q SCLC R/L 09	20	18	9,0	180	35	13	24	CC.. 09T3..	0,400	1440	5515	-	-	
A25R SCLC R/L 09	25	23	11,5	200	40	17	31	CC.. 09T3..	0,700	1440	5515	-	-	
A32S SCLC R/L 12	32	30	15,0	250	50	22	39	CC.. 1204..	1,400	1540	5517	3614	1760	
A40T SCLC R/L 12	40	37	18,5	300	60	27	48	CC.. 1204..	2,650	1540	5517	3614	1760	

With internal coolant
Anti-vibration shank
Державки с антивибрационным хвостовиком и внутренним подводом СОЖ

E-SCLC

	D	h	h1	L1	L2	f	A	Plates	kg					
E08K SCLC R/L 06	8	7	3,5	125	16	5	11	CC.. 0602..	0,080	1425	5507			
E10M SCLC R/L 06	10	9	4,5	150	25	7	13	CC.. 0602..	0,150	1425	5507			
E12M SCLC R/L 06	12	11	5,5	150	25	9	16	CC.. 0602..	0,250	1425	5507			
E16R SCLC R/L 09	16	15	7,5	200	30	11	20	CC.. 09T3..	0,600	1440	5515			

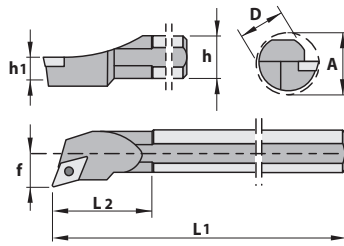
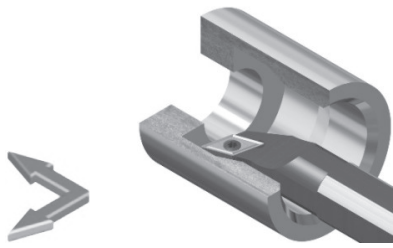

General angle 107°30'
Главный угол в плане 107°30'

Boring holders

SDQC

	D	h	h1	L1	L2	f	A	Plates					
S10M SDQC R/L 07	10	9	4,5	150	25	7	13	DC.. 0702..	0,060	1425	5507	-	-
S12M SDQC R/L 07	12	11	5,5	150	25	9	16	DC.. 0702..	0,150	1225	5507	-	-
S16R SDQC R/L 07	16	15	7,5	200	30	11	20	DC.. 0702..	0,300	1225	5507	-	-
S20S SDQC R/L 07	20	18	9,0	250	35	13	24	DC.. 0702..	0,550	1225	5507	-	-
S20S SDQC R/L 11	20	18	9,0	250	35	13	24	DC.. 11T3..	0,550	1240	5515	-	-
S25T SDQC R/L 11	25	23	11,5	300	40	17	31	DC.. 11T3..	0,700	1240	5515	-	-
S32U SDQC R/L 11	32	30	15,0	350	50	22	39	DC.. 11T3..	2,050	1335	5516	3714	1750
S40V SDQC R/L 11	40	37	18,5	400	60	27	48	DC.. 11T3..	3,750	1335	5516	3714	1750

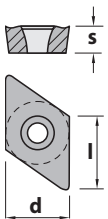

DC..	l	s	d
DC.. 0702..	7,75	2,38	6,35
DC.. 11T3..	11,60	3,97	9,52

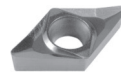
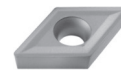
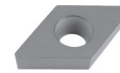
DCGT-AL

DCMT

DCMW

With internal coolant
Расточные державки
с внутренним подводом СОЖ

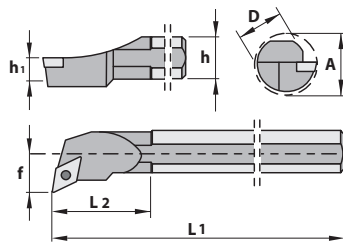
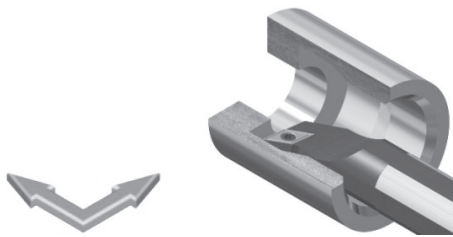
A-SDQC

	D	h	h1	L1	L2	f	A	Plates					
A12K SDQC R/L 07	12	11	5,5	125	25	9	16	DC.. 0702..	0,100	1225	5507	-	-
A16M SDQC R/L 07	16	15	7,5	150	30	11	20	DC.. 0702..	0,200	1225	5507	-	-
A20Q SDQC R/L 11	20	18	9,0	180	35	13	24	DC.. 11T3..	0,400	1240	5515	-	-
A25R SDQC R/L 11	25	23	11,5	200	40	17	31	DC.. 11T3..	0,700	1240	5515	-	-
A32S SDQC R/L 11	32	30	15,0	250	50	22	39	DC.. 11T3..	1,400	1335	5516	3714	1750
A40T SDQC R/L 11	40	37	18,5	300	60	27	48	DC.. 11T3..	2,650	1335	5516	3714	1750



General angle 93°
Главный угол в плане 93°

Boring holders

SDUC

	D	h	h1	L1	L2	f	A	Plates	kg				
S10M SDUC R/L 07	10	9	4,5	150	25	7	13	DC.. 0702..	0,060	1425	5507	-	-
S12M SDUC R/L 07	12	11	5,5	150	25	9	16	DC.. 0702..	0,150	1225	5507	-	-
S12Q SDUC R/L 07	12	11	5,5	180	25	9	16	DC.. 0702..	0,150	1225	5507	-	-
S16R SDUC R/L 07	16	15	7,5	200	30	11	20	DC.. 0702..	0,300	1225	5507	-	-
S20S SDUC R/L 07	20	18	9,0	250	35	13	24	DC.. 0702..	0,550	1225	5507	-	-
S20S SDUC R/L 11	20	18	9,0	250	35	13	24	DC.. 11T3..	0,550	1240	5515	-	-
S25T SDUC R/L 11	25	23	11,5	300	40	17	31	DC.. 11T3..	0,700	1240	5515	-	-
S32U SDUC R/L 11	32	30	15,0	350	50	22	39	DC.. 11T3..	2,050	1335	5516	3714	1750
S40V SDUC R/L 11	40	37	18,5	400	60	27	48	DC.. 11T3..	3,750	1335	5516	3714	1750

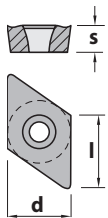

DC..	l	s	d
DC.. 0702..	7,75	2,38	6,35
DC.. 11T3..	11,60	3,97	9,52

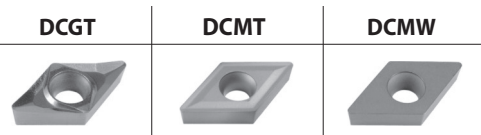

With internal coolant
Расточные державки с внутренним подводом СОЖ



A-SDUC 93°

	D	h	h1	L1	L2	f	A	Plates	kg				
A12K SDUC R/L 07	12	11	5,5	125	25	9	16	DC.. 0702..	0,100	1225	5507	-	-
A16M SDUC R/L 07	16	15	7,5	150	30	11	20	DC.. 0702..	0,200	1225	5507	-	-
A20Q SDUC R/L 11	20	18	9,0	180	35	13	24	DC.. 11T3..	0,400	1440	5515	-	-
A25R SDUC R/L 11	25	23	11,5	200	40	17	31	DC.. 11T3..	0,700	1240	5515	-	-
A32S SDUC R/L 11	32	30	15,0	250	50	22	39	DC.. 11T3..	1,400	1335	5516	3714	1750
A40T SDUC R/L 11	40	37	18,5	300	60	27	48	DC.. 11T3..	2,650	1335	5516	3714	1750

With internal coolant
Anti-vibration shank
Державки с антивибрационным хвостовиком и внутренним подводом СОЖ



E-SDUC 93°

	D	h	h1	L1	L2	f	A	Plates	kg		
E10M SDUC R/L 07	10	9	4,5	150	25	7	13	DC.. 0702..	0,150	1425	5507
E12M SDUC R/L 07	12	11	5,5	150	25	9	16	DC.. 0702..	0,250	1225	5507
E16R SDUC R/L 07	16	15	7,5	200	30	11	20	DC.. 0702..	0,600	1225	5507

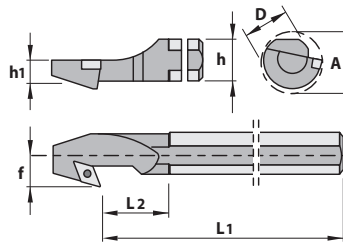
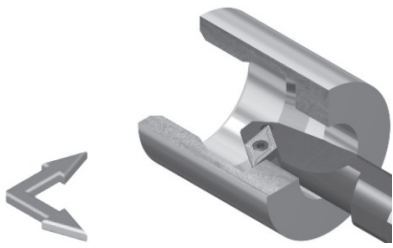

General angle 93°
Главный угол в плане 93°

Boring holders

SDUC

	D	h	h ₁	L ₁	L ₂	f	A	Plates					
S12M SDUC R/L 07-EX	12	11	5,5	150	25	9	16	DC.. 0702..	0,150	1225	5507	-	-
S16R SDUC R/L 07-EX	16	15	7,5	200	30	11	20	DC.. 0702..	0,300	1225	5507	-	-
S20S SDUC R/L 07-EX	20	18	9,0	250	35	13	24	DC.. 0702..	0,550	1225	5507	-	-
S20S SDUC R/L 11-EX	20	18	9,0	250	35	13	24	DC.. 11T3..	0,550	1240	5515	-	-
S25T SDUC R/L 11-EX	25	23	11,5	300	40	17	31	DC.. 11T3..	0,700	1240	5515	-	-
S32U SDUC R/L 11-EX	32	30	15,0	350	50	22	39	DC.. 11T3..	2,050	1335	5516	3714	1750
S40V SDUC R/L 11-EX	40	37	18,5	400	60	27	48	DC.. 11T3..	3,750	1335	5516	3714	1750

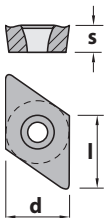

DC..	l	s	d
DC.. 0702..	7,75	2,38	6,35
DC.. 11T3..	11,60	3,97	9,52

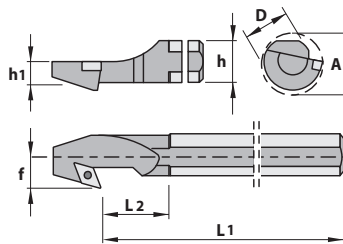
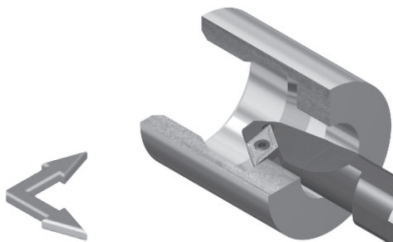
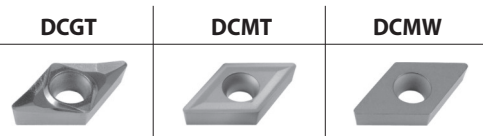

General angle 93°
Главный угол в плане 93°



With internal coolant
Расточные державки
с внутренним подводом СОЖ

A-SDUC

	D	h	h ₁	L ₁	L ₂	f	A	Plates			
A12K SDUC R/L 07-EX	12	11	5,5	125	25	9	16	DC.. 0702..	0,100	1225	5507
A16M SDUC R/L 07-EX	16	15	7,5	150	30	11	20	DC.. 0702..	0,200	1225	5507
A20Q SDUC R7L 11-EX	20	18	9,0	180	35	13	24	DC.. 11T3..	0,400	1240	5515
A25R SDUC R/L 11-EX	25	23	11,5	200	40	17	31	DC.. 11T3..	0,700	1240	5515

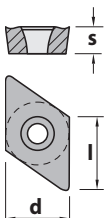

DC..	l	s	d
DC.. 0702..	7,75	2,38	6,35
DC.. 11T3..	11,60	3,97	9,52

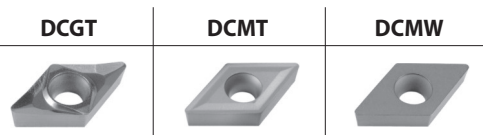

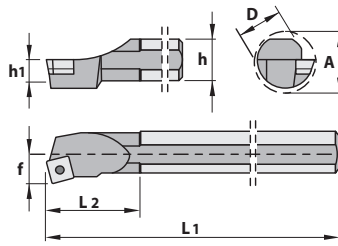
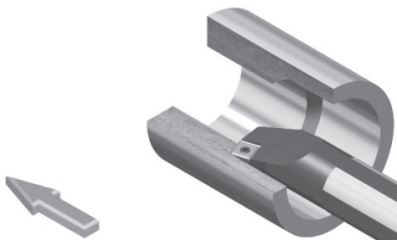

General angle 75°
Главный угол в плане 75°

Boring holders

SSKC

	D	h	h1	L1	L2	f	A	Plates					
S16R SSKC R/L 09	16	15	7,5	200	30	11	20	SC.. 09T3..	0,300	1440	5515	-	-
S20S SSKC R/L 09	20	18	9,0	250	35	13	24	SC.. 09T3..	0,550	1240	5515	-	-
S25T SSKC R/L 09	25	23	11,5	300	40	17	31	SC.. 09T3..	0,700	1240	5515	-	-
S32U SSKC R/L 12	32	30	15,0	350	50	22	39	SC.. 1204..	2,050	1540	5517	3514	1760
S40V SSKC R/L 12	40	37	18,5	400	60	27	48	SC.. 1204..	3,750	1540	5517	3514	1760
S50W SSKC R/L 12	50	47	23,5	450	65	35	61	SC.. 1204..	6,500	1540	5517	3514	1760

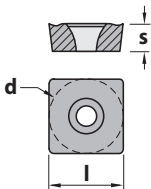

SC..	l	s	d
SC.. 09T3..	9,52	3,97	9,52
SC.. 1204..	12,70	4,76	12,70

SCGT	SCMT	SCMW

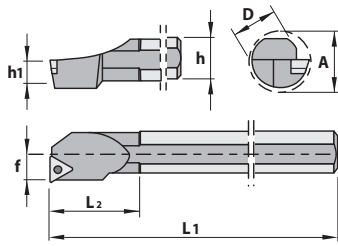
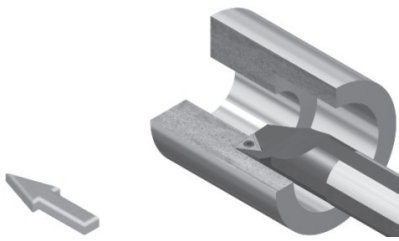

General angle 90°
Главный угол в плане 90°

Boring holders

STFC

	D	h	h ₁	L ₁	L ₂	f	A	Plates					
S10M STFC R/L 09	10	9	4,5	150	25	7	13	TC.. 0902..	0,060	1222	5506	-	-
S12M STFC R/L 09	12	11	5,5	150	25	9	16	TC.. 0902..	0,150	1222	5506	-	-
S12M STFC R/L 11	12	11	5,5	150	25	9	16	TC.. 1102..	0,150	1225	5507	-	-
S12Q STFC R/L 11	12	11	5,5	180	25	9	16	TC.. 1102..	0,050	1225	5507	-	-
S16R STFC R/L 11	16	15	7,5	200	30	11	20	TC.. 1102..	0,300	1225	5507	-	-
S20S STFC R/L 11	20	18	9,0	250	35	13	24	TC.. 1102..	0,550	1225	5507	-	-
S20S STFC R/L 16	20	18	9,0	250	35	13	24	TC.. 16T3..	0,550	1240	5515	-	-
S25T STFC R/L 16	25	23	11,5	300	40	17	31	TC.. 16T3..	0,700	1240	5515	-	-
S32U STFC R/L 16	32	30	15,0	350	50	22	39	TC.. 16T3..	2,050	1335	5516	3414	1750
S40V STFC R/L 16	40	37	18,5	400	60	27	48	TC.. 16T3..	3,750	1335	5516	3414	1750

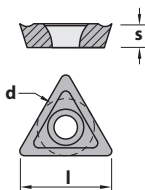

TC..	l	s	d
TC.. 0902..	9,62	2,38	5,55
TC.. 1102..	11,00	2,38	6,35
TC.. 16T3..	16,50	3,97	9,52



With internal coolant
Расточные державки
с внутренним подводом СОЖ

A-STFC 90°

	D	h	h ₁	L ₁	L ₂	f	A	Plates					
A10H STFC R/L 09	10	9	4,5	100	25	7	13	TC.. 0902..	0,040	1222	5506	-	-
A12K STFC R/L 11	12	11	5,5	125	25	9	16	TC.. 1102..	0,100	1225	5507	-	-
A16M STFC R/L 11	16	15	7,5	150	30	11	20	TC.. 1102..	0,200	1225	5507	-	-
A20Q STFC R/L 11	20	18	9,0	180	35	13	24	TC.. 1102..	0,400	1225	5507	-	-
A25R STFC R/L 16	25	23	11,5	200	40	17	31	TC.. 16T3..	0,700	1240	5515	-	-
A32S STFC R/L 16	32	30	15,0	250	50	22	39	TC.. 16T3..	1,400	1335	5516	3414	1750
A40T STFC R/L 16	40	37	18,5	300	60	27	48	TC.. 16T3..	2,650	1335	5516	3414	1750



With internal coolant
Anti-vibration shank
Державки с антивибрационным
хвостовиком и внутренним подводом СОЖ

E-STFC 90°

	D	h	h ₁	L ₁	L ₂	f	A	Plates			
E10M STFC R/L 09	10	9	4,5	150	25	7	13	TC.. 0902..	0,150	1222	5506
E12M STFC R/L 11	12	11	5,5	150	25	9	16	TC.. 1102..	0,250	1225	5507
E16R STFC R/L 11	16	15	7,5	200	30	11	20	TC.. 1102..	0,600	1440	5515

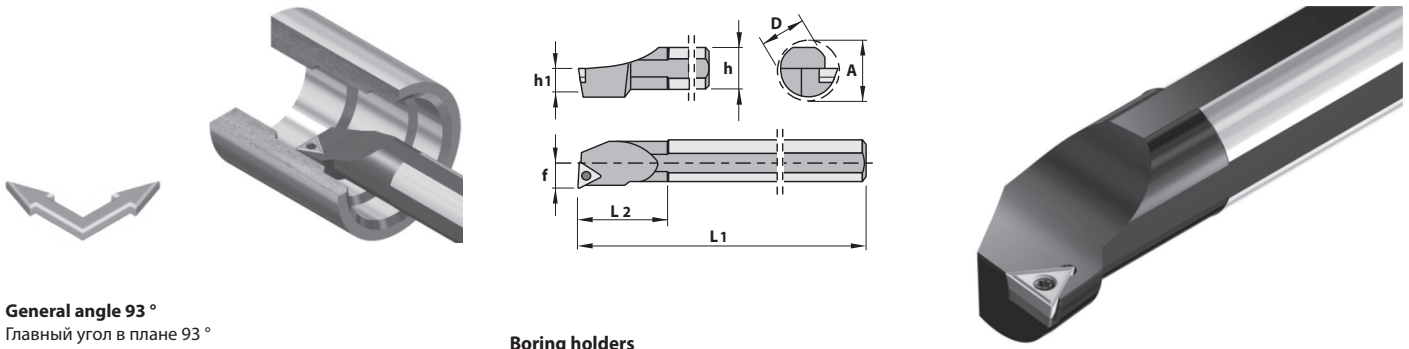

General angle 93°
Главный угол в плане 93°

Boring holders

STUC

	D	h	h1	L1	L2	f	A	Plates					
S12M STUC R/L 11	12	11	5,5	150	25	9	16	TC.. 1102..	0,150	1225	5507	-	-
S16R STUC R/L 16	16	15	7,5	200	30	11	20	TC.. 16T3..	0,300	1240	5515	-	-
S20S STUC R/L 16	20	18	9,0	250	35	13	24	TC.. 16T3..	0,550	1240	5515	-	-
S25T STUC R/L 16	25	23	11,5	300	40	17	31	TC.. 16T3..	0,700	1240	5515	-	-
S32U STUC R/L 16	32	30	15,0	350	50	22	39	TC.. 16T3..	2,050	1335	5516	3414	1750

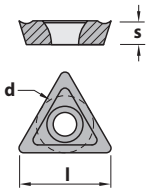

TC..	l	s	d	TCGT	TCMT	TCMW
TC.. 1102..	11,00	2,38	6,35			
TC.. 16T3..	16,50	3,97	9,52			

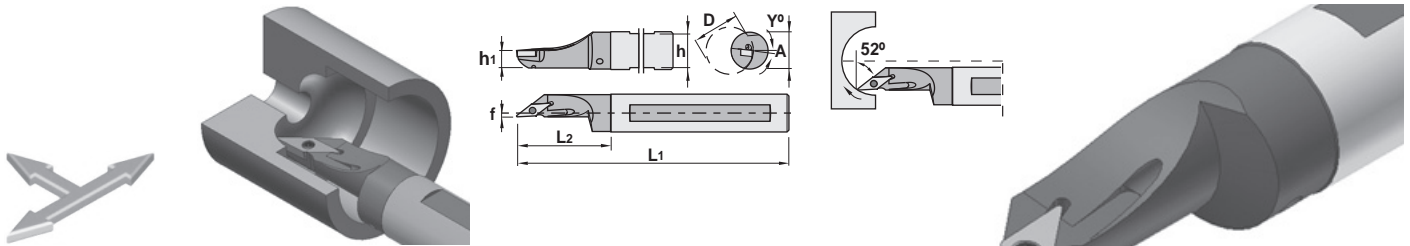

General angle 52°
Главный угол в плане 52°

With internal coolant
Расточные державки с внутренним подводом СОЖ

SVJC

	D	h	h1	L1	L2	A	f	Y°	Plates			
A16M SVJC R/L 11	16	15	7,5	150	30	22	2	6	VC.. 1103..	0,000	1225	5507
A20Q SVJC R/L 11	20	18	9,0	180	38	25	2	5	VC.. 1103..	0,350	1225	5507
A25R SVJC R/L 16	25	23	11,5	200	44	28	2	4	VC.. 1604..	0,000	1240	5515

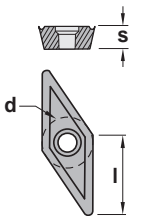

VC..	l	s	d	VCGT	VCMT
VC.. 1103..	11,00	3,18	6,35		
VC.. 1604..	16,50	4,76	9,52		

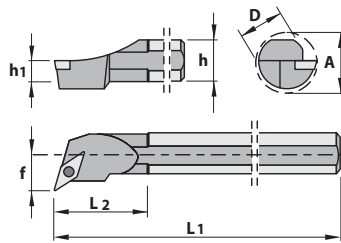
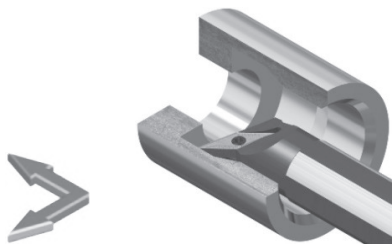

General angle 107°30'

Boring holders

SVQC

	D	h	h ₁	L ₁	L ₂	f	A	Plates					
S16R SVQC R/L 11	16	15	7,5	200	30	11	20	VC.. 1103..	0,300	1225	5507	-	-
S20S SVQC R/L 11	20	18	9,0	250	35	13	24	VC.. 1103..	0,550	1225	5507	-	-
S16R SVQC R/L 13	16	15	7,5	200	30	13	22	VC.. 1303..	0,300	1230	5508	-	-
S20S SVQC R/L 13	20	18	9,0	250	35	13	24	VC.. 1303..	0,550	1230	5508	-	-
S25T SVQC R/L 16	25	23	11,5	300	40	17	31	VC.. 1604..	0,700	1335	5516	3718	1750

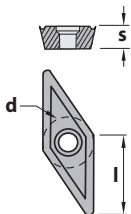

VC..	l	s	d	VCGT	VCMT
VC.. 1103..	11,00	3,18	6,35		
VC.. 1303..	13,00	3,18	8,00		
VC.. 1604..	16,50	4,76	9,52		

With internal coolant
 Расточные державки
 с внутренним подводом СОЖ

A-SVQC

	D	h	h ₁	L ₁	L ₂	f	A	Plates					
A16M SVQC R/L 11	16	15	7,5	150	30	11	20	VC.. 1103..	0,200	1225	5507	-	-
A20Q SVQC R/L 11	20	18	9,0	180	35	13	24	VC.. 1103..	0,400	1225	5507	-	-
A25R SVQC R/L 16	25	23	11,5	200	40	17	31	VC.. 1604..	0,700	1335	5516	3718	1750
A32S SVQC R/L 16	32	30	15,0	250	50	22	39	VC.. 1604..	1,400	1335	5516	3718	1750
A40T SVQC R/L 16	40	37	18,5	300	60	27	48	VC.. 1604..	2,650	1335	5516	3718	1750

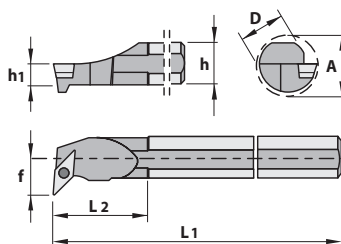
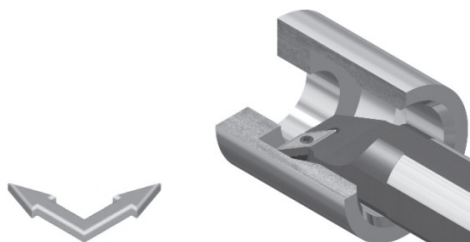

General angle 93°

Главный угол в плане 93°

Boring holders

SVUB

	D	h	h ₁	L ₁	L ₂	f	A	Plates					
S25T SVUB R/L 16	25	23	11,5	300	40	17	31	VBMT 1604..	0,700	1335	5516	3718	1750
S32U SVUB R/L 16	32	30	15,0	350	50	22	39	VBMT 1604..	2,050	1335	5516	3718	1750
S40V SVUB R/L 16	40	37	18,5	400	60	27	48	VBMT 1604..	3,750	1335	5516	3718	1750

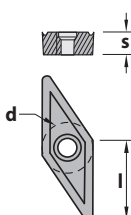

VBMT	l	s	d	VBMT
VBMT 1604..	16,50	4,76	9,52	

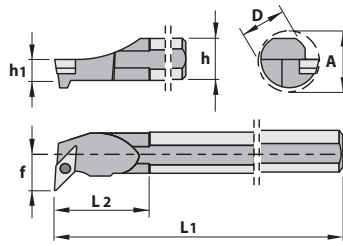
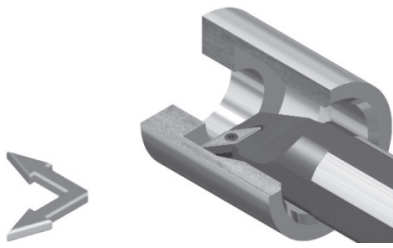

General angle 93°
Главный угол в плане 93°

Boring holders

SVUC

	D	h	h1	L1	L2	f	A	Plates					
S16R SVUC R/L 11	16	15	7,5	200	30	11	20	VC.. 1103..	0,300	1225	5507	-	-
S20S SVUC R/L 11	20	18	9,0	250	35	13	24	VC.. 1103..	0,550	1225	5507	-	-
S25T SVUC R/L 16	25	23	11,5	300	40	17	31	VC.. 1604..	0,700	1335	5516	3718	1750
S32U SVUC R/L 16	32	30	15,0	350	50	22	39	VC.. 1604..	2,050	1335	5516	3718	1750
S40V SVUC R/L 16	40	37	18,5	400	60	27	48	VC.. 1604..	3,750	1335	5516	3718	1750

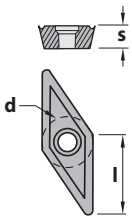

VC..	l	s	d	VCGT	VCMT
VC.. 1103..	11,00	3,18	6,35		
VC.. 1604..	16,50	4,76	9,52		

A-SVUC



With internal coolant
Расточные державки
с внутренним подводом СОЖ

	D	h	h1	L1	L2	f	A	Plates					
A16M SVUC R/L 11	16	15	7,5	150	30	11	20	VC.. 1103..	0,200	1225	5507	-	-
A20Q SVUC R/L 11	20	18	9,0	180	35	13	24	VC.. 1103..	0,400	1225	5507	-	-
A25R SVUC R/L 16	25	23	11,5	200	40	17	31	VC.. 1604..	0,700	1335	5516	3718	1750
A32S SVUC R/L 16	32	30	15,0	250	50	22	39	VC.. 1604..	1,400	1335	5516	3718	1750
A40T SVUC R/L 16	40	37	18,5	300	60	27	48	VC.. 1604..	2,650	1335	5516	3718	1750



TOOLS WITH CARBIDE INSERTS
ИНСТРУМЕНТ СО СМЕННЫМИ ТВЕРДОСПЛАВНЫМИ ПЛАСТИНАМИ

GROOVING AND PARTING OFF
КАНАВКА И ОТПРЕЗКА

TABLE OF CONTENTS / СОДЕРЖАНИЕ

SOLID CARBIDE TOOLS		3
ТВЕРДОСПЛАВНЫЙ ИНСТРУМЕНТ		
1	Carbide mills Твердосплавные фрезы	5
2	Carbide drills Твердосплавные сверла	39
3	Special tools Специальные инструменты	49
TOOLS WITH CARBIDE INSERTS		54
ИНСТРУМЕНТ СО СМЕННЫМИ ТВЕРДОСПЛАВНЫМИ ПЛАСТИНАМИ		
4	Turning carbide inserts Токарные твердосплавные пластины	55
5	Toolholders for external turning Токарные державки для наружной обработки	91
6	Toolholders for internal turning Токарные державки для внутренней обработки	123
7	Grooving and parting off Канавка и отрезка	143
<input type="checkbox"/>	Alloy description Описание сплавов	145
<input type="checkbox"/>	Chipbreakers Описание стружколомов	146
<input type="checkbox"/>	Toolfinder Применяемость инструмента	148
<input type="checkbox"/>	Inserts Выбор пластин	150
<input type="checkbox"/>	Toolholders for external turning of grooves Державки для наружного точения канавок	162
<input type="checkbox"/>	Face grooving holders Державки для обработки торцевых канавок	163
<input type="checkbox"/>	Radial Cartridge Сменные картриджи	166
<input type="checkbox"/>	Axial Cartridges Торцевые сменные картриджи	167
<input type="checkbox"/>	Module Holder Модульные державки	168
<input type="checkbox"/>	Blades for parting off Отрезные ножи	170
<input type="checkbox"/>	Toolholders with cooling Державки с внутренним подводом СОЖ	172
8	Threading inserts Резьбонарезные пластины	175
9	Milling with carbide inserts Фрезы со сменными твердосплавными пластинами	217
10	Drills with carbide inserts Сверла со сменными пластинами	271

M120G

HC-P30 | HC-M25 | HC-K30 | HC-S30

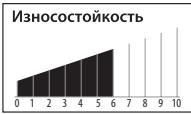
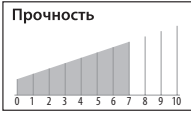

Specification:

Composition: Co 9.0 %; mixed carbides 2.0 %; WC balance | Grain size: 0.7-1 μm | Hardness: HV30 1590 | Coating specification: PVD TiAlN

Recommended application: The universal high-performance grade for steel, austenitic steel, cast iron and heat-resistant alloys.

Состав: Со 9.0%; соединения карбидов 2.0% WC остальное; Размер зерна: 0,7 - 1 μm; Твердость: HV 1590; Состав покрытия: PVD TiAlN 4 μm;

Рекомендации к применению: Универсальный высокопроизводительный сплав для стали, нержавеющей стали, чугуна и жаропрочных сплавов.

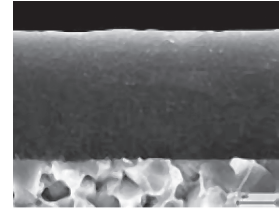

PK320T

HC-P35 | HC-K35 | HC-M30

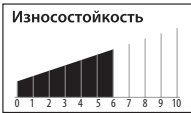
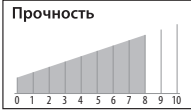

Specification:

Composition: Co 10.5 %; mixed carbides 2.0 %; WC balance | Grain size: 1 μm | Hardness: HV30 1400 | Coating specification: CVD TiCN-Al2O3 multi-layer

Recommended application: The reliable choice for the machining of steel and cast iron.

Состав: Со 10.5%; соединения карбидов 2.0% WC остальное; Размер зерна: 1 μm; Твердость: HV 1400; Состав покрытия: CVD TiCN-Al2O3 многослойное;

Рекомендации к применению: Для обработки стали и чугуна.

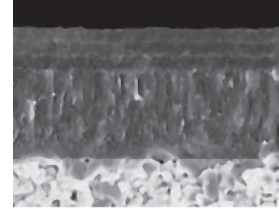

M345G

HC-P45 | HC-M40 | HC-S40

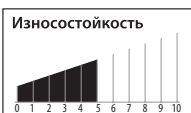
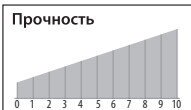

Specification:

Composition: Co 12.5 %; mixed carbides 2.0 %; WC balance | Grain size: 1-1.5 μm | Hardness: HV30 1380 | Coating specification: PVD TiAlTaN

Recommended application: The reliable solution for steel and austenitic steels under unstable conditions.

Состав: Со 12.5%; соединения карбидов 2.0% WC остальное; Размер зерна: 1-1,5μm; Твердость: HV 1380; Состав покрытия: PVD TiAlN;

Рекомендации к применению: Надежное решение для обработки стали и нержавеющей сталей в условиях нестабильного резания.

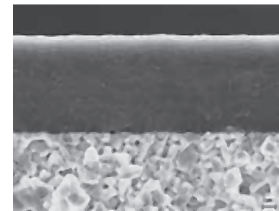

N216T

HW-N15 | HW-K15

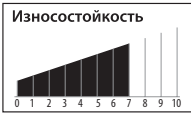

Specification:

Composition: Co 6.0 %; WC balance | Grain size: 1 μm | Hardness: HV30 1630

Recommended application: The uncoated carbide grade for the machining of aluminium and other non-ferrous metals

Состав: Со 6.0%; WC остальное; Размер зерна: 1 μm; Твердость: HV 1630; Состав покрытия: Без покрытия;

Рекомендуемое применение: Непокрытый твердый сплав для обработки алюминия и других цветных металлов.

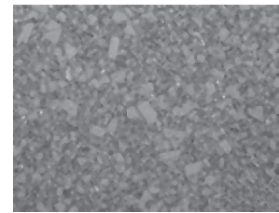

Grades/ Сплавы	ISO	Cutting material Режущий материал	Application/ Область применения										P Steel Сталь	M Stainless steel Нержавеющая сталь	K Cast iron Чугун	N Aluminium Легкие сплавы	S Superalloy Жаропрочные сплавы		
			01	05	10	15	20	25	30	35	40	45						50	
M120G	HC-P30	P																	
	HC-M25	P																	
	HC-K30	P																	
	HC-S30	P																	
PK320T	HC-P35	C																	
	HC-K35	C																	
	HC-M30	C																	
M345G	HC-P45	P																	
	HC-M40	P																	
	HC-S40	P																	
N216T	HC-N15	W																	
	HC-K15	W																	

*** РЕЖУЩИЙ МАТЕРИАЛ**

- T - cermet/кермет без покрытия
- C - with CVD coating/сплав с покрытием CVD
- P - with PVD coating/сплав с покрытием PVD
- W - without coating/сплав без покрытия

● First choice

Наилучшее применение

○ Second choice

Допустимое применение

UM1



Insert with narrow negative chamfer
Universal application
The first choice for cutting off

Пластина с широкой отрицательной фаской
Универсальное применение по всем видам материалов
Первый выбор для отрезки прутка



SST1



Especially for stainless steel and heat-resistant alloys

Первый выбор для обработки нержавеющей стали и жаропрочных сплавов



UF1



Excellent cutting chipbreaker with low cutting forces
High cutting edge stability
Processing of thin-walled elements and viscous materials

Острая геометрия стружколома с низкой силой резания
Высокая стабильность работы режущей кромки
Обработка тонкостенных элементов и вязких материалов



UT



For grooving and turning
Universal application

Пластина для канавок и точения
Универсальное применение



UL1

Aluminum processing
Insert with highly positive cutting chipbreaker
and sharp cutting edge
Extra-smooth rake face through "microfinish"
Reduced built-up edge

Обработка алюминия
Пластина с высокоэффективным режущим стружколомом и острой режущей кромкой
Сверхгладкая поверхность стружколома для снижения наростообразования

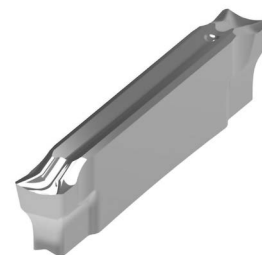
**UR**

Insert for radius grooves
Universal application

Пластина для радиусных канавок и
точения профиля
Универсальное применение

**URM****NEW**

Especially for stainless steel materials
Insert for radius grooves
Specially designed geometry for stainless steel and heat-resistant alloys

Пластина для радиусных канавок и точения профиля
Специально разработанная геометрия для нержавеющей
стали и жаропрочных сплавов



0° THR/Lx00...IC / p.168
Module holder / Модульные державки



ER/L...WD24/WF24 / p.162
External grooving / Наружная канавка



Cutting width
Ширина канавки
h = 1.5...8.0

RCE...WD24/WF24 / p.163
Reinforced / Усиленная канавка



Cutting width
Ширина канавки
h = 2.0...3.0

GIN...WD24 / p.169
Internal / Внутренняя канавка



Cutting width
Ширина канавки
h = 2.0...5.0

ICR/L...WD24 / p.165
Cartridge / Сменные картриджи



Cutting width
Ширина канавки
h = 2.0...6.0

WD24

WF24

Radial inserts

Радиальные пластины

UM1

h = 1.5...8.0

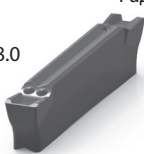

UF1

h = 2.0...5.0

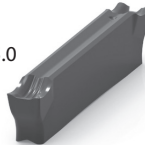

SST1

h = 2.0...6.0

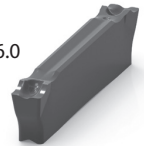

UT1

h = 2.0...5.0

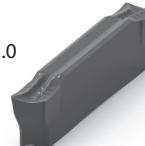

UL1

h = 2.0...4.0

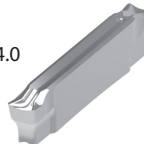

UR

h = 2.0...6.0



p.150

Radial inserts for deep grooving

Радиальные пластины для глубокой канавки

UM1

h = 1.5...4.0

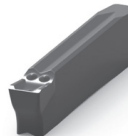

SST1

h = 2.0...5.0

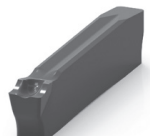

UF1

h = 2.0...4.0

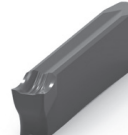

UT1

h = 2.0...4.0

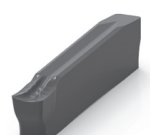

UL1

h = 2.0...4.0



p.154

ER/L...WD24/WF24-IC / p.172

External grooving with cooling / Наружная канавка с подводом СОЖ

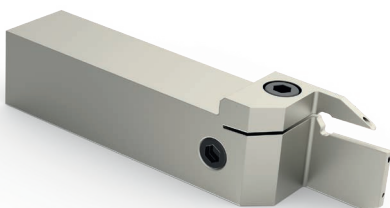

Cutting width
Ширина канавки
h = 1.5...8.0

RCE...WD24/WF24-IC / p.173

Reinforced with cooling / Усиленная канавка с подводом СОЖ



Cutting width
Ширина канавки
h = 2.0...3.0

**EN...WF24N...
EN...WSN...** / p.172

EN...WF24N...IC
Blades / Отрезные ножи



Cutting width
Ширина канавки
h = 2.0...3.0

45° THR/Lx45...IC / p.168
Module holder / Модульные державки



90° THR/Lx90...IC / p.168
Module holder / Модульные державки

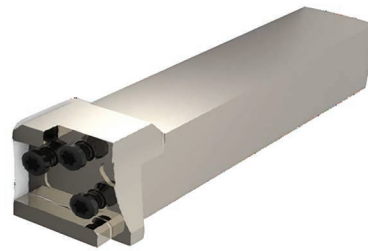

ER/L...WSN / p.164
External grooving / Наружная канавка



Cutting width
Ширина канавки
h = 2.0...6.0

ICR/L...G24 / p.165
Face grooving cartridge / Торцевые картриджи



Cutting width
Ширина канавки
h = 3.0...4.0

E25R/L...FG24 / p.166
Face grooving / Торцевая канавка



Cutting width
Ширина канавки
h = 3.0...5.0

WSN

FG24

Radial inserts
Радиальные пластины

UM1 h = 2.0...6.0		SST1 h = 2.0...6.0	
UT1 h = 2.0...6.0		ULM1 h = 2.0...6.0	

p.156

Axis inserts
Торцевые пластины

UT h = 3.0...5.0	
UR h = 3.0...4.0	

p.160



END... / p.173
Blocks / Блоки отрезных ножей



END...IC / p.173
Blocks with cooling / Блоки отрезных ножей с подводом СОЖ

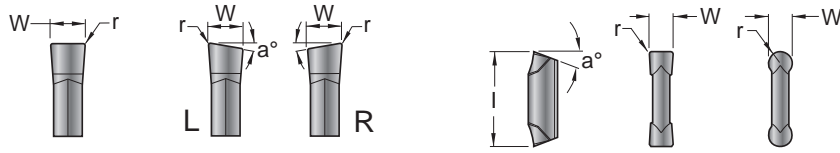

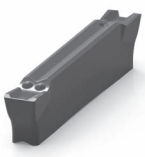

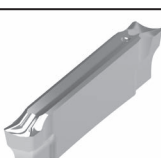
Sort of insert Вид пластины	Art. / Арт.	W	r/s	l	a°	Grades Сплавы			
						M120G	PK320T	M345G	N216T
	N WD24N 1.5.015-00-UM1	1.5	0.15	24	0	●	●	●	
	L WD24L 2.15-06-UM1	2.0	0.15	24	6	●	●	●	
	N WD24N 2.02-00-UM1	2.0	0.2	24	0	●	●	●	
	R WD24R 2.15-06-UM1	2.0	0.15	24	6	●	●	●	
	L WD24L 3.02-06-UM1	3.0	0.2	24	6	●	●	●	
	N WD24N 3.02-00-UM1	3.0	0.2	24	0	●	●	●	
	R WD24R 3.02-06-UM1	3.0	0.2	24	6	●	●	●	
	N WD24N 4.03-00-UM1	4.0	0.3	24	0	●	●	●	
	N WD24N 5.04-00-UM1	5.0	0.4	24	0	●	●	●	
	N WD24N 6.04-00-UM1	6.0	0.4	24	0	●	●	●	
	N WD35N 8.08-00-UM1	8.0	0.8	35	0	●			
	N WD24N 1.5.015-0.0-SST1	1.5	0.15	24	-	●	●	●	
	L WD24L 2.015-06-SST1	2.0	0.15	24	6	●	●	●	
	N WD24N 2.02-00-SST1	2.0	0.2	24	0	●	●	●	
	R WD24R 2.015-06-SST1	2.0	0.15	24	6	●	●	●	
	L WD24L 3.02-06-SST1	3.0	0.2	24	6	●	●	●	
	N WD24N 3.02-00-SST1	3.0	0.2	24	0	●	●	●	
	R WD24R 3.02-06-SST1	3.0	0.2	24	6	●	●	●	
	N WD24N 4.04-00-SST1	4.0	0.4	24	0	●	●	●	
	N WD24N 5.04-00-SST1	5.0	0.4	24	0	●	●	●	
	N WD24N 6.04-00-SST1	6.0	0.4	24	0	●	●	●	
		N WD24N 2.02-00-UL1	2.0	0.2	24	0			
N WD24N 3.03-00-UL1		3.0	0.3	24	0				●
N WD24N 4.04-00-UL1		4.0	0.4	24	0				●
						M120G	PK320T	M345G	N216T
P Steel - Сталь						★	★	★	
M Stainless steel aust. - Аустенитная нерж. сталь						★	☆	★	
K Cast iron- Чугун						★	★		
N Aluminium - Алюминиевые сплавы									★
S Hig. temp. alloy - Жаропрочные сплавы						★		★	

★ Наилучшее применение ☆ Допустимое применение

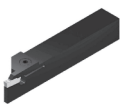

р.160

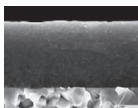

р.145



р.165

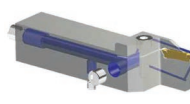

р.172



р.169

Feed rate for partig off inserts

Параметры подачи для канавочных и отрезных пластин (UM1)

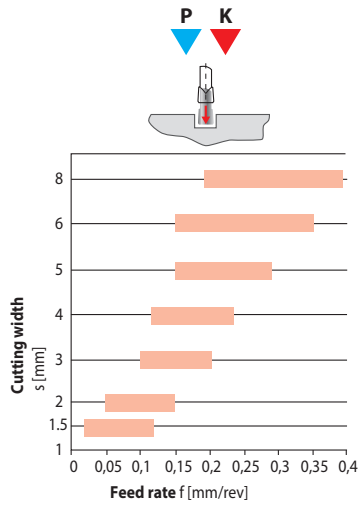

Feed rate for partig off inserts

Параметры подачи для канавочных и отрезных пластин (SST1)

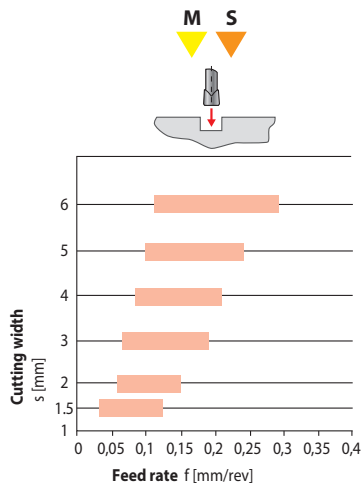

Feed rate for partig off inserts

Параметры подачи для канавочных и отрезных пластин (UL1)

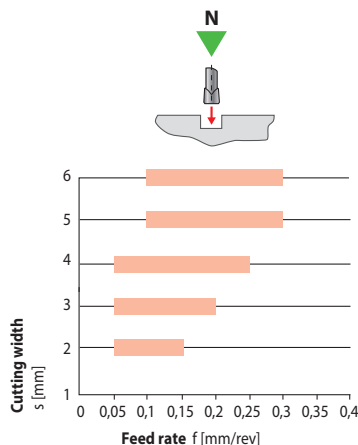



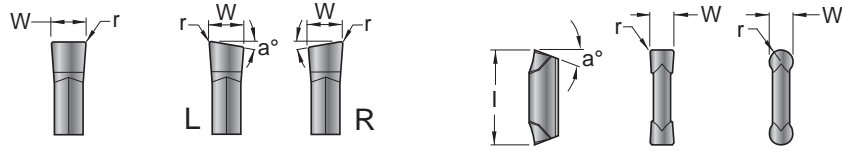

ISO	Cutting material/ Обрабатываемый материал	Hardness Твердость HB	Cutting Speed/ Скорость резания, m/min		
			120G VC [m/ min]	PK320T VC [m/ min]	M345G VC [m/ min]
P	Non alloyed steel 0.15% – 0.45% C	150-250	80-180	110-190	80-150
	Low alloyed steel tempered	250-300	60-150	110-180	70-120
	High alloyed steel tempered	350	50-120	70-160	60-100
	Corrosion resistant steel annealed	200	50-200	120-200	90-160
M	Annealed pearlitic	200	50-200	120-200	100-180
	Quenched austenitic	180	50-180	100-170	80-150
	Quenched duplex	230-260	50-100	70-110	70-110
	Hardened martensitic	330	50-80	60-90	60-90
K	Grey cast iron	180	100-200	90-180	-
	Spheroidal	160	100-180	100-160	-
	Quenched cast iron	160	80-160	80-150	-

ISO	Cutting material/ Обрабатываемый материал	Hardness Твердость HB	Cutting Speed/ Скорость резания, m/min		
			M120G VC [m/ min]	PK320T VC [m/ min]	M345G VC [m/ min]
M	Non-quenched ferritic	200	50-200	120-200	100-180
	Quenched austenitic	180	50-180	100-170	80-150
	Quenched duplex	230-260	50-100	70-110	70-110
	Hardened martensitic	330	50-80	60-90	60-90
S	Iron based	200	-	-	20-45
	Nickel or Cobalt based	250	-	-	15-25
	Titanium alloys	Rm 440	-	-	50-120

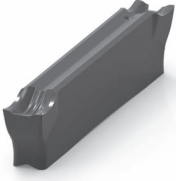
ISO	Cutting material/ Обрабатываемый материал	Hardness Твердость HB	Cutting Speed/ Скорость резания, m/min
			M120G VC [m/min]
N	I Деформируемые сплавы	100	200-2000
	N Литейные сплавы <12% Si	90	400-1500
	C Медные сплавы	90	200-600



Sort of insert Вид пластины	Art. / Apr.	W	r/s	l	a°/d1	Grades Сплавы			
						M120G	PK320T	M345G	N216T
	L WD24L 2.015-06-UF1	2.0	0.15	24	6	●	●	●	
	N WD24N 2.02-00-UF1	2.0	0.2	24	0	●	●	●	
	R WD24R 2.015-06-UF1	2.0	0.15	24	6	●	●	●	
	L WD24L 3.02-06-UF1	3.0	0.2	24	6	●	●	●	
	N WD24N 3.02-00-UF1	3.0	0.2	24	0	●	●	●	
	R WD24R 3.02-06-UF1	3.0	0.2	24	6	●	●	●	
	N WD24N 4.03-00-UF1	4.0	0.3	24	0	●	●	●	
	N WD24N 5.04-00-UF1	5.0	0.4	24	0	●	●	●	
	L WD24L 2.02-06-UT	2.0	0.2	24	6	●	●	●	
	N WD24N 2.02-00-UT	2.0	0.2	24	0	●	●	●	
	R WD24R 2.02-06-UT	2.0	0.2	24	6	●	●	●	
	L WD24L 3.02-06-UT	3.0	0.2	24	6	●	●	●	
	N WD24N 3.03-00-UT	3.0	0.3	24	0	●	●	●	
	R WD24R 3.02-06-UT	3.0	0.2	24	6	●	●	●	
	N WD24N 4.04-00-UT	4.0	0.4	24	0	●	●	●	
	N WD24N 5.04-00-UT	5.0	0.4	24	0	●	●	●	
	N WD24N 2.00S-1.0-UR	2	1.0	24	-	●	●	●	
	N WD24N 3.00S-1.5-UR	3	1.5	24	-	●	●	●	
	N WD24N 4.00S-2.0-UR	4	2.0	24	-	●	●	●	
	N WD24N 5.00S-2,5-UR	5	2.5	24	-	●	●	●	
	N WD24N 6.00S-3.0-UR	6	3.0	24	-	●	●	●	
	N WD24N 2.00S-1.0-URM	2	1.0	24	-	●	●	●	
	N WD24N 3.00S-1.5-URM	3	1.5	24	-	●	●	●	
	N WD24N 4.00S-2.0-URM	4	2.0	24	-	●	●	●	
	N WD24N 5.00S-2,5-URM	5	2.5	24	-	●	●	●	
	N WD24N 6.00S-3.0-URM	6	3.0	24	-	●	●	●	
						M120G	PK320T	M345G	N216T
P Steel - Сталь						★	★	★	
M Stainless steel aust. - Аустенитная нерж. сталь						★	☆	★	
K Cast iron - Чугун						★	★		
N Aluminium - Алюминиевые сплавы									★
S Hig. temp. alloy - Жаропрочные сплавы						★		★	

★ Наилучшее применение ☆ Допустимое применение



p.160

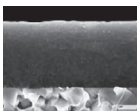

p.145



p.165



p.172

Feed rate for partig off inserts

Параметры подачи для канавочных и отрезных пластин (UF1)

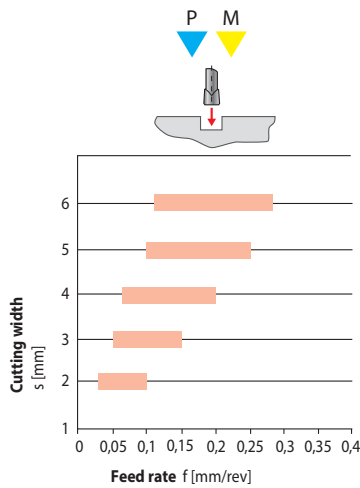

Feed rate for partig off inserts

Параметры подачи для канавочных и отрезных пластин (UT)

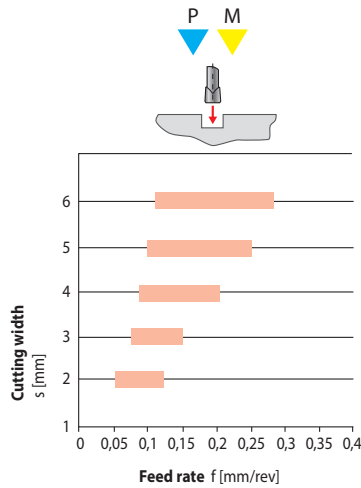

Feed rate for partig off inserts

Параметры подачи для канавочных и отрезных пластин (UR)

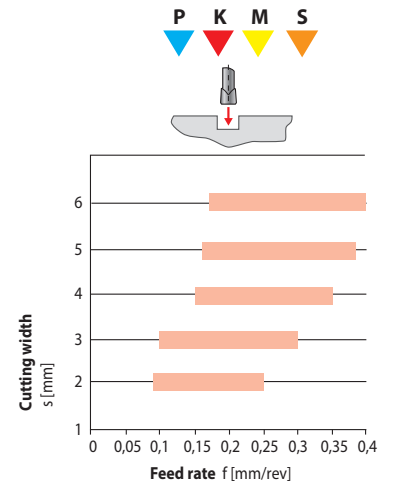

ISO	Cutting material/ Обрабатываемый материал	Hardness Твердость HB	Cutting Speed/ Скорость резания, м/мин		
			M120G VC [m/min]	PK320T VC [m/min]	M345G VC [m/min]
P	Steel/Сталь				
	Non alloyed steel 0.15% – 0.45% C Нелегированная сталь	150-250	80-180	110-190	80-150
	Low alloyed steel tempered Низколегированная сталь	250-300	60-150	110-180	70-120
	High alloyed steel tempered Высоколегированная сталь	350	50-120	70-160	60-100
	Corrosion resistant steel annealed Сталь устойчивая к коррозии	200	50-200	120-200	90-160
M	Stainless steel/ Нержавеющая сталь				
	Annealed pearlitic Отожженная перлитная	200	50-200	120-200	100-180
	Quenched austenitic Закаленная аустенитная	180	50-180	100-170	80-150
	Quenched duplex Аустенитно-ферритная (дуплекс)	230-260	50-100	70-110	70-110
	Hardened martensitic Мартенситная закаленная	330	50-80	60-90	60-90
K	Cast iron/Чугун				
	Grey cast iron Серый чугун	180	100-200	90-180	-
	Spheroidal Шаровидный чугун	160	100-180	100-160	-
	Quenched cast iron Закаленный чугун	160	80-160	80-150	-

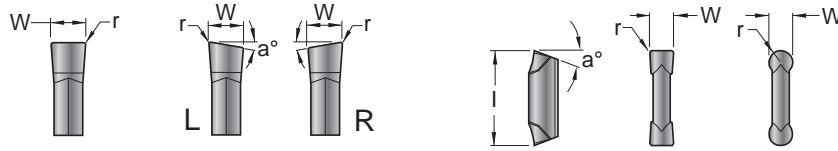

Sort of insert Вид пластины	Art. / Apr.	W	r/s	l	a°/d1	Grades Сплавы			
						M120G	PK320T	M345G	N216T
	WF24N 2.02-00-UM1	2.0	0.2	24	0	●	●	●	
	WF24N 3.02-00-UM1	3.0	0.2	24	0	●	●	●	
	WF24N 4.03-00-UM1	4.0	0.3	24	0	●	●	●	
	WF24N 2.02-00-UF1	2.0	0.2	24	0	●	●	●	
	WF24N 3.02-00-UF1	3.0	0.2	24	0	●	●	●	
	WF24N 4.03-00-UF1	4.0	0.3	24	0	●	●	●	
	WF24N 2.02-00-SST1	2.0	0.2	24	0	●	●	●	
	WF24N 3.03-00-SST1	3.0	0.3	24	0	●	●	●	
	WF24N 4.03-00-SST1	4.0	0.3	24	0	●	●	●	
	WF24N 2.02-00-UT	2.0	0.2	24	0	●	●	●	
	WF24N 3.03-00-UT	3.0	0.3	24	0	●	●	●	
	WF24N 4.04-00-UT	4.0	0.4	24	0	●	●	●	
	WF24N 2.02-00-UL1	2.0	0.2	24	0				●
	WF24N 3.02-00-UL1	3.0	0.2	24	0				●
	WF24N 4.03-00-UL1	4.0	0.3	24	0				●
						M120G	PK320T	M345G	N216T
P Steel - Сталь						★	★	★	
M Stainless steel aust. - Аустенитная нерж. сталь						★	☆	★	
K Cast iron - Чугун						★	★		
N Aluminium - Алюминиевые сплавы									★
S Hig. temp. alloy - Жаропрочные сплавы						★		★	

★ Наилучшее применение ☆ Допустимое применение



p.164

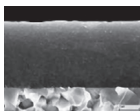

p.145



p.172



p.173

Feed rate for partig off inserts

Параметры подачи для канавочных и отрезных пластин (UM1/UF1)

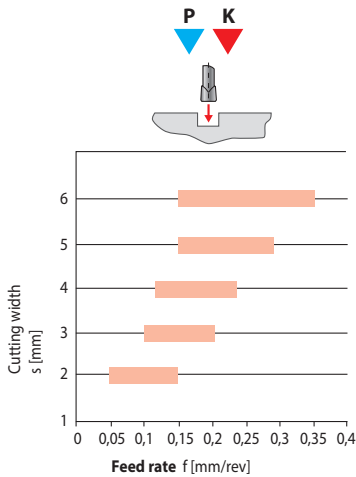

Feed rate for partig off inserts

Параметры подачи для канавочных и отрезных пластин (SST1)

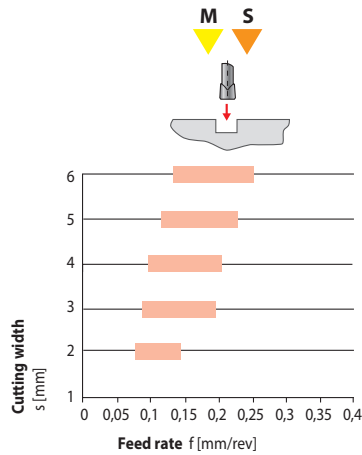

Feed rate for partig off inserts

Параметры подачи для канавочных и отрезных пластин (UT)

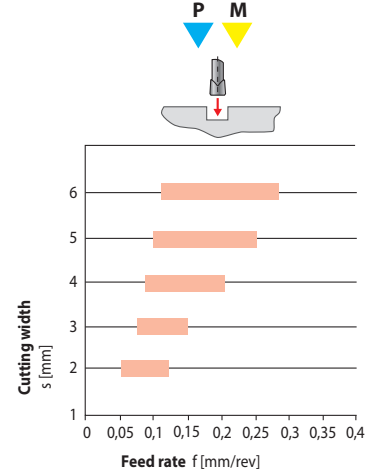

ISO	Cutting material/ Обрабатываемый материал	Hardness Твердость HB	Cutting Speed/ Скорость резания, м/мин		
			M120G VC [m/min]	PK320T VC [m/min]	M345G VC [m/min]
P	Non alloyed steel 0.15% – 0.45% C Нелегированная сталь	150-250	80-180	110-190	80-150
	Low alloyed steel tempered Низколегированная сталь	250-300	60-150	110-180	70-120
	High alloyed steel tempered Высоколегированная сталь	350	50-120	70-160	60-100
	Corrosion resistant steel annealed Сталь устойчивая к коррозии	200	50-200	120-200	90-160
M	Annealed pearlitic Отожженная перлитная	200	50-200	120-200	100-180
	Quenched austenitic Закаленная аустенитная	180	50-180	100-170	80-150
	Quenched duplex Аустенитно-ферритная (дуплекс)	230-260	50-100	70-110	70-110
	Hardened martensitic Мартенситная закаленная	330	50-80	60-90	60-90
K	Grey cast iron Серый чугун	180	100-200	90-180	-
	Spheroidal Шаровидный чугун	160	100-180	100-160	-
	Quenched cast iron Закаленный чугун	160	80-160	80-150	-
S	Iron based На основе железа	200	-	-	20-45
	Nickel or Cobalt based На основе никеля или кобальта	250	-	-	15-25
	Titanium alloys Титановые сплавы	Rm 440	-	-	50-120

Feed rate for partig off inserts

Параметры подачи для канавочных и отрезных пластин (UL1)

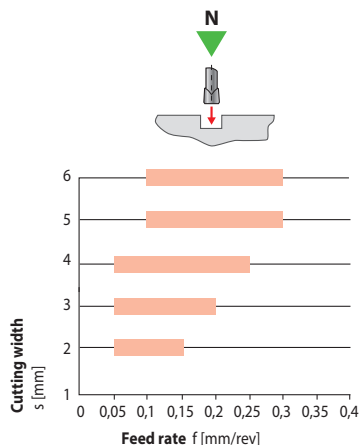

ISO	Cutting material/ Обрабатываемый материал	Hardness Твердость HB	Cutting Speed/ Скорость резания, м/мин
			M120G VC [m/min]
N	I Деформируемые сплавы	100	200-2000
	N Литейные сплавы <12% Si	90	400-1500
	C Медные сплавы	90	200-600

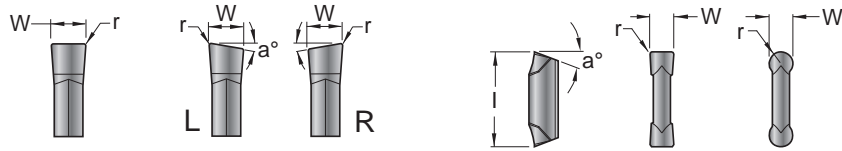

Sort of isert Вид пластины	Art. / Apr.	W	r/s	l	a°/d1	Grades Сплавы			
						M120G	PK320T	M345G	N216T
 UM1	WSN 2.02.00-UM1	2.0	0.2	-	-	●	●	●	
	WSN 3.02.00-UM1	3.0	0.2	-	-	●	●	●	
	WSN 4.03.00-UM1	4.0	0.3	-	-	●	●	●	
	WSN 5.03.00-UM1	5.0	0.3	-	-	●	●	●	
	WSN 6.04.00-UM1	6.0	0.4	-	-	●	●	●	
 UT	WSN 2.02.00-UT	2.0	0.2	-	-	●	●	●	
	WSN 3.03.00-UT	3.0	0.3	-	-	●	●	●	
	WSN 4.04.00-UT	4.0	0.4	-	-	●	●	●	
	WSN 5.04.00-UT	5.0	0.4	-	-	●	●	●	
	WSN 6.05.00-UT	6.0	0.5	-	-	●	●	●	
 SST1	WSN 2.02.00-SST1	2.0	0.2	-	-	●	●	●	
	WSN 3.02.00-SST1	3.0	0.2	-	-	●	●	●	
	WSN 4.04.00-SST1	4.0	0.4	-	-	●	●	●	
	WSN 5.04.00-SST1	5.0	0.4	-	-	●	●	●	
	WSN 6.04.00-SST1	6.0	0.4	-	-	●	●	●	
 UL1	WSN 2.02.00-UL1	2.0	0.2	-	-				●
	WSN 3.03.00-UL1	3.0	0.3	-	-				●
	WSN 4.04.00-UL1	4.0	0.4	-	-				●
	WSN 5.04.00-UL1	5.0	0.4	-	-				●
	WSN 6.04.00-UL1	6.0	0.4	-	-				●
						M120G	PK320T	M345G	N216T
P Steel - Сталь						★	★	★	
M Stainless steel aust. - Аустенитная нерж. сталь						★	☆	★	
K Cast iron- Чугун						★	★		
N Aluminium - Алюминиевые сплавы									★
S Hig. temp. alloy - Жаропрочные сплавы						★		★	

★ Наилучшее применение ☆ Допустимое применение

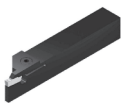

p.164

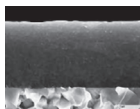

p.145



p.172



p.173

Feed rate for partig off inserts

Параметры подачи для канавочных и отрезных пластин (UM1)

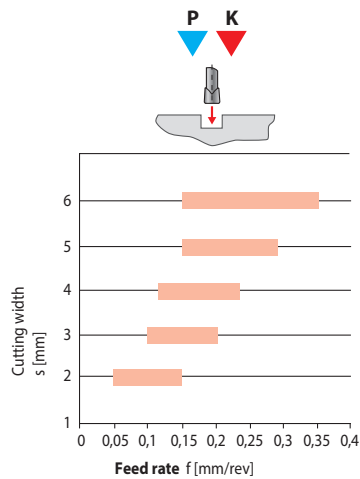

Feed rate for partig off inserts

Параметры подачи для канавочных и отрезных пластин (SST1)

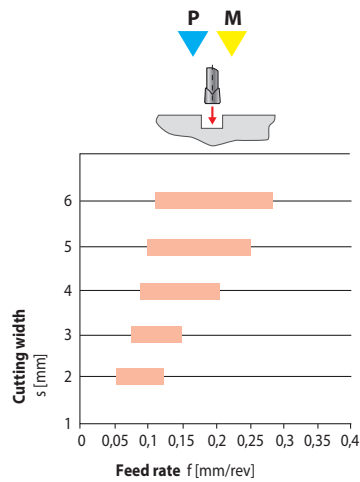

Feed rate for partig off inserts

Параметры подачи для канавочных и отрезных пластин (UT)

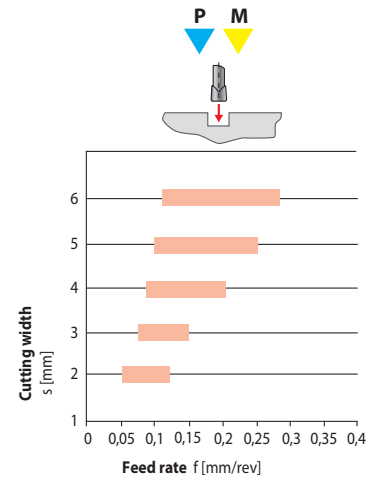

ISO	Cutting material/ Обрабатываемый материал	Hardness Твердость HB	Cutting Speed/ Скорость резания, м/мин		
			M120G VC [m/min]	PK320T VC [m/min]	M345G VC [m/min]
P	Non alloyed steel 0.15% – 0.45% C Нелегированная сталь	150-250	80-180	110-190	80-150
	Low alloyed steel tempered Низколегированная сталь	250-300	60-150	110-180	70-120
	High alloyed steel tempered Высоколегированная сталь	350	50-120	70-160	60-100
	Corrosion resistant steel annealed Сталь устойчивая к коррозии	200	50-200	120-200	90-160
M	Annealed pearlitic Отожженная перлитная	200	50-200	120-200	100-180
	Quenched austenitic Закаленная аустенитная	180	50-180	100-170	80-150
	Quenched duplex Аустенитно-ферритная (дуплекс)	230-260	50-100	70-110	70-110
	Hardened martensitic Мартенситная закаленная	330	50-80	60-90	60-90
K	Grey cast iron Серый чугун	180	100-200	90-180	-
	Spheroidal Шаровидный чугун	160	100-180	100-160	-
	Quenched cast iron Закаленный чугун	160	80-160	80-150	-
S	Iron based На основе железа	200	-	-	20-45
	Nickel or Cobalt based На основе никеля или кобальта	250	-	-	15-25
	Titanium alloys Титановые сплавы	Rm 440	-	-	50-120

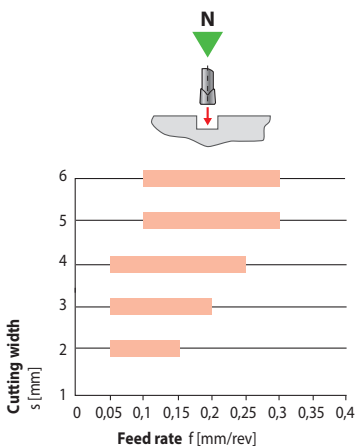

Feed rate for partig off inserts

Параметры подачи для канавочных и отрезных пластин (UL1)

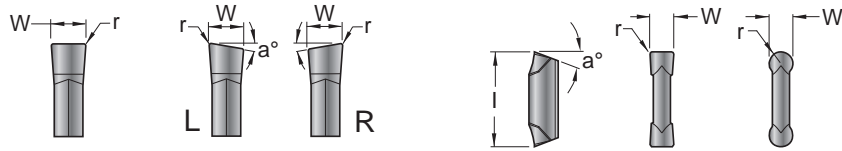

ISO	Cutting material/ Обрабатываемый материал	Hardness Твердость HB	Cutting Speed/ Скорость резания, м/мин
			N216T VC [m/min]
N	I Деформируемые сплавы	100	200-2000
	N Литейные сплавы <12% Si	90	400-1500
	C Медные сплавы	90	200-600



Sort of isert Вид пластины	Art. / Apr.	W	r/s	l	a°/d1	Grades Сплавы			
						M120G	PK320T	M345G	N216T
 UR	WSN 2.00.00-UR	2.0	1.0	-	-	●			
	WSN 3.00.00-UR	3.0	1.5	-	-	●			
	WSN 4.00.00-UR	4.0	2.0	-	-	●			
	WSN 5.00.00-UR	5.0	2.5	-	-	●			
	WSN 6.00.00-UR	6.0	3.0	-	-	●			
 URM	WSN 2.00.00-URM	2.0	1.0	-	-	●			
	WSN 3.00.00-URM	3.0	1.5	-	-	●			
	WSN 4.00.00-URM	4.0	2.0	-	-	●			
	WSN 5.00.00-URM	5.0	2.5	-	-	●			
	WSN 6.00.00-URM	6.0	3.0	-	-	●			
						M120G	PK320T	M345G	N216T
P Steel - Сталь						★	★	★	
M Stainless steel aust. - Аустенитная нерж. сталь						★	☆	★	
K Cast iron- Чугун						★	★		
N Aluminium - Аллюминиевые сплавы									★
S Hig. temp. alloy - Жаропрочные сплавы						★		★	

★ Наилучшее применение ☆ Допустимое применение

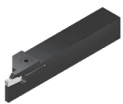

p.164

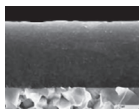

p.145



p.172



p.173

Feed rate for partig off inserts

Параметры подачи для канавочных и отрезных пластин (UR)

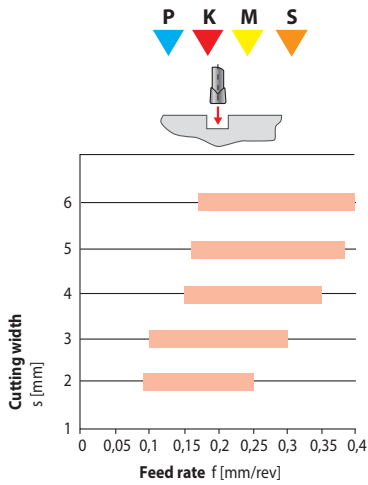

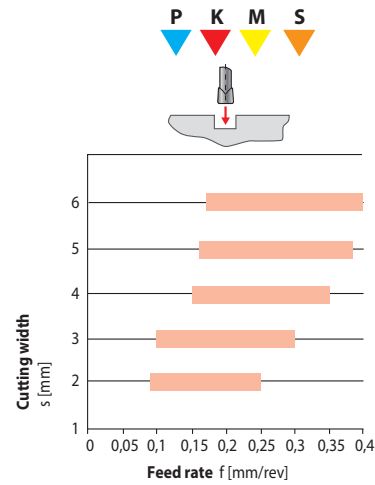

Feed rate for partig off inserts

Параметры подачи для канавочных и отрезных пластин (URM)

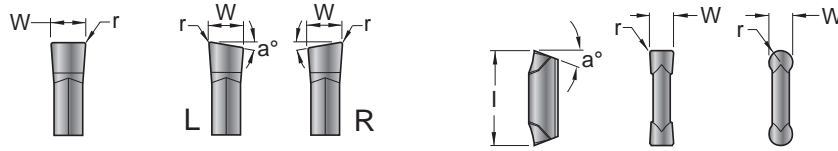

ISO	Cutting material/ Обрабатываемый материал	Hardness Твердость HB	Cutting Speed/ Скорость резания, m/min		
			M120G VC [m/min]	PK320T VC [m/min]	M345G VC [m/min]
P	Non alloyed steel 0.15% – 0.45% C Нелегированная сталь	150-250	80-180	110-190	80-150
	Low alloyed steel tempered Низколегированная сталь	250-300	60-150	110-180	70-120
	High alloyed steel tempered Высоколегированная сталь	350	50-120	70-160	60-100
	Corrosion resistant steel annealed Сталь устойчивая к коррозии	200	50-200	120-200	90-160
M	Annealed pearlitic Отожженная перлитная	200	50-200	120-200	100-180
	Quenched austenitic Закаленная аустенитная	180	50-180	100-170	80-150
	Quenched duplex Аустенитно-ферритная (дуплекс)	230-260	50-100	70-110	70-110
	Hardened martensitic Мартенситная закаленная	330	50-80	60-90	60-90
K	Grey cast iron Серый чугун	180	100-200	90-180	-
	Spheroidal Шаровидный чугун	160	100-180	100-160	-
	Quenched cast iron Закаленный чугун	160	80-160	80-150	-
S	Iron based На основе железа	200	-	-	20-45
	Nickel or Cobalt based На основе никеля или кобальта	250	-	-	15-25
	Titanium alloys Титановые сплавы	Rm 440	-	-	50-120



Sort of isert Вид пластины	Art. / Арт.	W	r/s	l	a°/d1	Grades Сплавы			
						M120G	PK320T	M345G	N216T
	FG24N 3.03-00-UT	3.0	0.3	24	0	●	●	●	
	FG24N 4.04-00-UT	4.0	0.4	24	0	●	●	●	
	FG24N 5.04-00-UT	5.0	0.4	24	0	●	●	●	
	FG24N 3.00-00-UR	3.0	1.5	24	0	●	●	●	
	FG24N 4.00-00-UR	4.0	2.0	24	0	●	●	●	
						M120G	PK320T	M345G	N216T
P Steel - Сталь						★	★	★	
M Stainless steel aust. - Аустенитная нерж. сталь						★	☆	★	
K Cast iron- Чугун						★	★		
N Aluminium - Алюминиевые сплавы									★
S Hig. temp. alloy - Жаропрочные сплавы						★		★	

★ Наилучшее применение ☆ Допустимое применение

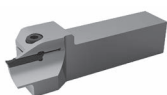

p.166

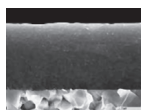

p.145



p.167

Feed rate for face grooving

Параметры подачи для обработки торцевых канавок (UT)

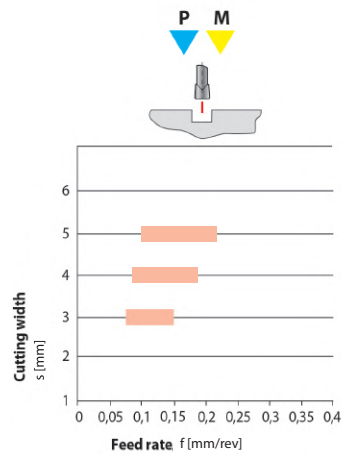

Feed rate for face grooving

Параметры подачи для обработки торцевых канавок (UR)

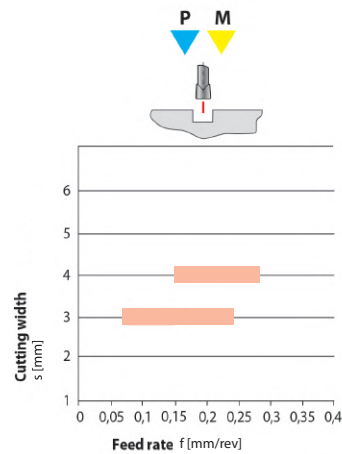

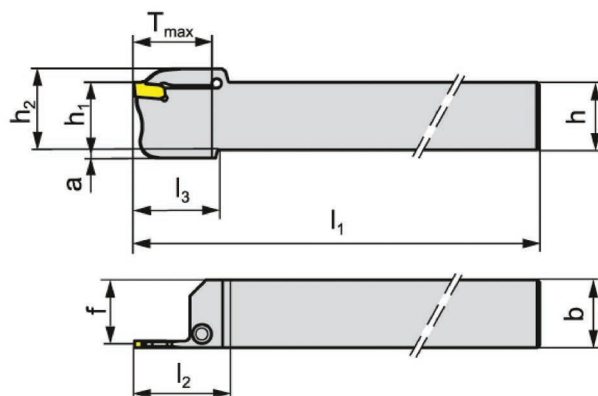

ISO	Cutting material/ Обрабатываемый материал	Hardness Твердость HB	Cutting Speed/ Скорость резания, м/мин		
			M120G VC [m/min]	PK320T VC [m/min]	M345G VC [m/min]
P	Non alloyed steel 0.15% – 0.45% C Нелегированная сталь	150-250	80-180	110-190	80-150
	Low alloyed steel tempered Низколегированная сталь	250-300	60-150	110-180	70-120
	High alloyed steel tempered Высоколегированная сталь	350	50-120	70-160	60-100
	Corrosion resistant steel annealed Сталь устойчивая к коррозии	200	50-200	120-200	90-160
M	Annealed pearlitic Отожженная перлитная	200	50-200	120-200	100-180
	Quenched austenitic Закаленная аустенитная	180	50-180	100-170	80-150
	Quenched duplex Аустенитно-ферритная (дуплекс)	230-260	50-100	70-110	70-110
	Hardened martensitic Мартенситная закаленная	330	50-80	60-90	60-90
K	Grey cast iron Серый чугун	180	100-200	90-180	-
	Spheroidal Шаровидный чугун	160	100-180	100-160	-
	Quenched cast iron Закаленный чугун	160	80-160	80-150	-

Toolholders for external turning of grooves / Державки для наружного точения канавок





Right hand / Изображена правая державка

ART. APT.	Insert type. Тип пластины	W	T _{max} (mm)	b	h	L ₁		
E12R/L0023-1212K-WD24-1.5	WD24	1.5	23	12	12	125	7897218/T20	7897207/T20
E16R/L0023-1616K-WD24-1.5		1.5	23	16	16	125	7897218/T20	7897207/T20
E12R/L0013-1212K-WD24-2	WD24 / WF24	2	13	12	12	125	7897221/T15	7897208/T15
E16R/L0013-1616K-WD24-2		2	13	16	16	125	M0102554/T20	7897207/T20
E20R/L0013-2020K-WD24-2		2	13	20	20	125	7897218/T20	7897207/T20
E12R/L0013-1212K-WD24-3	WD24 / WF24	3	13	12	12	125	7897221/T15	7897208/T15
E16R/L0013-1616K-WD24-3		3	13	16	16	125	M0102554/T20	7897207/T20
E20R/L0013-2020K-WD24-3		3	13	20	20	125	7897218/T20	7897207/T20
E25R/L0013-2525K-WD24-3		3	13	25	25	125	7897218/T20	
E16R/L0025-1616K-WD24-3		3	25	16	16	125	M0102554/T20	7897207/T20
E20R/L0025-2020K-WD24-3		3	25	20	20	125	7897218/T20	7897207/T20
E25R/L0025-2525K-WD24-3		3	25	25	25	125	7897218/T20	7897207/T20
E32R/L0025-3232P-WD24-3		3	25	32	32	170	7897218/T20	7897207/T20
E40R/L0025-4040S-WD24-3	3	25	40	40	250	7897218/T20	7897207/T20	
E16R/L0025-1616K-WD24-4	WD24 / WF24	4	25	16	16	125	M0102554/T20	7897207/T20
E20R/L0025-2020K-WD24-4		4	25	20	20	125	7897218/T20	7897207/T20
E25R/L0025-2525K-WD24-4		4	25	25	25	125	7897218/T20	7897207/T20
E20R/L0025-2020M-WD24-5	WD24 / WF24	5	25	20	20	150	7897218/T20	7897207/T20
E25R/L0025-2525M-WD24-5		5	25	25	25	150	7897218/T20	7897207/T20
E20R/L0025-2020M-WD24-06		6	25	20	20	150	7897218/T20	7897207/T20
E25R/L0025-2525M-WD24-06		6	25	25	25	150	11007006	120165558
E32R/L0025-3232P-WD24-06		6	25	32	32	170	7897218/T20	7897207/T20
E40R/L0025-4040S-WD24-06		6	25	40	40	250	11007006	120165558
E25R/L0032-2525P-WD35-08	WD35	8	32	25	25	170	7897218/T20	7897207/T20
E32R/L0032-3232P-WD35-08		8	32	32	32	170	11007006	120165558

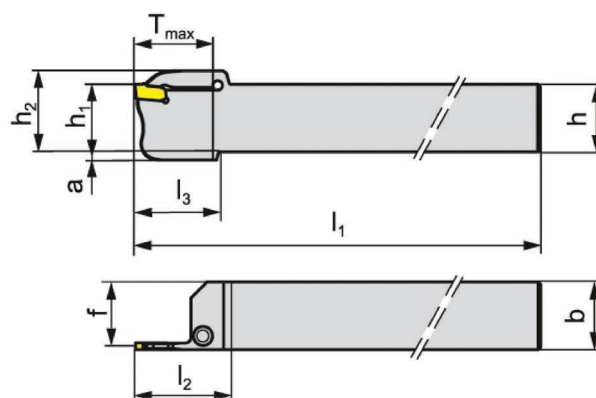
Toolholders for external turning of grooves / Державки для наружного точения канавок



Right hand / Изображена правая державка

ART. APT.	Insert type. Тип пластины	W	T _{max} (mm)	b	h	L ₁		
RCE12R/L0013-1212K-WD24-2	WD24/WF24	2	13	12	12	125	195068	12380791
RCE16R/L0013-1616K-WD24-2		2	13	16	16	125	195068	12380791
RCE12R/L0021-1212K-WD24-2	WD24 / WF24	2	21	12	12	125	195068	12380791
RCE16R/L0021-1616K-WD24-2		2	21	16	16	125	195068	12380791
RCE12R/L0013-1212K-WD24-3	WD24 / WF24	3	13	12	12	125	195068	12380791
RCE16R/L0013-1616K-WD24-3		3	13	16	16	125	195068	12380791
RCE12R/L0021-1212K-WD24-3	WD24 / WF24	3	21	12	12	125	195068	12380791
RCE16R/L0021-1616K-WD24-3		3	21	16	16	125	195068	12380791

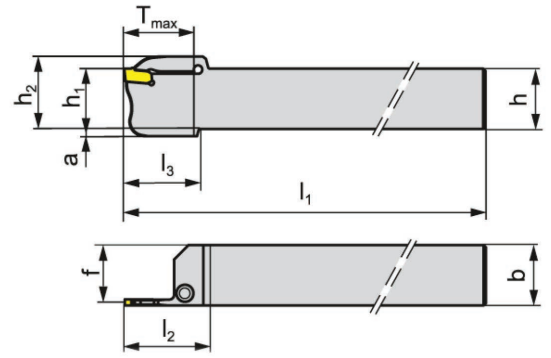

Right hand / Изображена правая державка

ART. APT.	Insert type. Тип пластины	W	T _{max} (mm)	h	b	L ₁		
E16R/L0020-1616K-WSN-2	WSN	2	20	16	16	125	11007006	12380793
E20R/L0020-2020K-WSN-2		2	20	20	20	125	11007006	12380793
E16R/L0020-1616K-WSN-3	WSN	3	20	16	16	125	11007006	12380793
E20R/L0020-2020K-WSN-3		3	20	20	20	125	11007006	12380793
E25R/L0020-2525M-WSN-3		3	20	25	25	150	11007006	12380793
E20R/L0025-2020K-WSN-4	WSN	4	25	20	20	125	11007006	12380793
E25R/L0025-2525M-WSN-4		4	25	25	25	150	11007006	12380793
E20R/L0025-2020K-WSN-5	WSN	5	25	20	20	125	11007006	12380793
E25R/L0025-2525M-WSN-5		5	25	25	25	150	11007006	12380793
E20R/L0025-2020K-WSN-6	WSN	6	25	20	20	125	11007006	12380793
E25R/L0032-2525M-WSN-6		6	32	25	25	150	11007006	12380793

Face grooving holders / Державки для обработки торцевых канавок

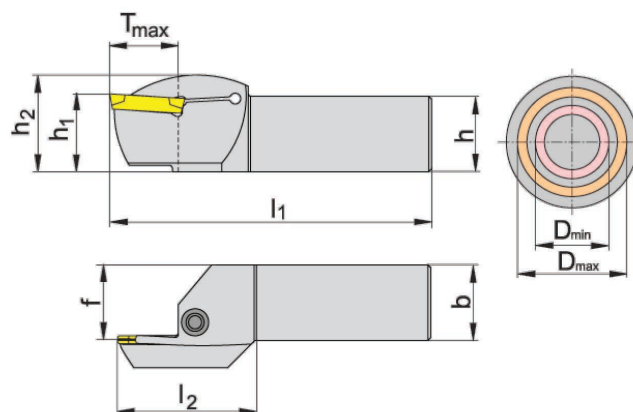

Right hand / Изображена правая державка

ART. APT.	Insert type. Тип пластины	W	T _{max} (mm)	D _{min} (mm)	D _{max} (mm)	h2	h=h1	b	L ₂	f	L ₁
E25R/L0013-2525K-40-50-FG24-3	FG24	3	13	40	50	33	25	25	39,7	24,3	125
E25R/L0013-2525K-50-60-FG24-3		3	13	50	60	33	25	25	39,7	24,3	125
E25R/L0013-2525K-60-70-FG24-3		3	13	60	75	33	25	25	39,7	24,3	125
E25R/L0013-2525K-75-100-FG24-3		3	13	75	100	33	25	25	39,7	24,3	125
E25R/L0013-2525K-100-140-FG24-3		3	13	100	140	33	25	25	39,7	24,3	125
E25R/L0013-2525K-140-200-FG24-3		3	13	140	200	33	25	25	39,7	24,3	125
E25R/L0013-2525K-40-50-FG24-4	FG24	4	13	40	50	33	25	25	39,7	24,3	125
E25R/L0013-2525K-50-60-FG24-4		4	13	50	60	33	25	25	39,7	24,3	125
E25R/L0013-2525K-60-70-FG24-4		4	13	60	75	33	25	25	39,7	24,3	125
E25R/L0013-2525K-75-100-FG24-4		4	13	75	100	33	25	25	39,7	24,3	125
E25R/L0013-2525K-100-140-FG24-4		4	13	100	140	33	25	25	39,7	24,3	125
E25R/L0013-2525K-140-200-FG24-4		4	13	140	200	33	25	25	39,7	24,3	125
E25R/L0020-2525K-45-60-FG24-5	FG24	5	20	45	60	33	25	25	39	23,3	125
E25R/L0020-2525K-60-75-FG24-5		5	20	60	75	33	25	25	39	23,3	125
E25R/L0028-2525K-75-100-FG24-5		5	28	75	100	33	25	25	47	23,3	125
E25R/L0028-2525K-100-180-FG24-5		5	28	100	180	33	25	25	47	23,3	125
E25R/L0032-2525K-180-400-FG24-5		5	32	180	400	33	25	25	51	23,3	125

Radial Cartridge / Сменные картиджи

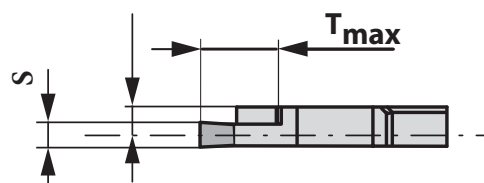
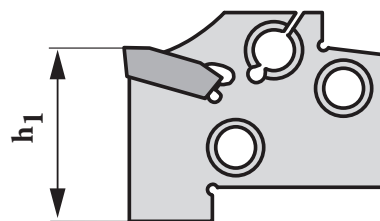

Right hand / Изображена правая державка

ART. APT.	Insert type. Тип пластины	S	T _{max} (mm)	h	h ₁
ICR/L0025-20-WF24-2	WF24/WD24	2	25	20	20
ICR/L0025-25-WF24-2		2	25	25	25
ICR/L0025-20-WF24-3		3	25	20	20
ICR/L0025-25-WF24-3		3	25	25	25
ICR/L0025-20-WF24-4		4	25	20	20
ICR/L0025-25-WF24-4		4	25	25	25
ICR/L0025-20-WF24-5		5	25	20	20
ICR/L0025-25-WF24-5		5	25	25	25
ICR/L0025-20-WF24-6		6	25	20	20
ICR/L0025-25-WF24-6		6	25	25	25

Axial Cartridge / Торцевые сменные картиджи

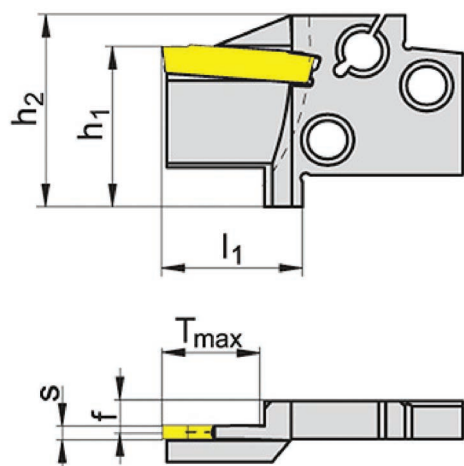

Right hand / Изображена правая державка

ART. APT.	Insert type. Тип пластины	S	T _{max} (mm)	D _{min} (mm)	D _{max} (mm)	h2	h=h1	L ₁	f
ICR/L0015-2525K-40-50-FG24-3	FG24	3	15	40	50	30	25	22	4.9
ICR/L0015-2525K-50-60-FG24-3		3	15	50	60	30	25	22	4.9
ICR/L0015-2525K-60-70-FG24-3		3	15	60	75	30	25	22	4.9
ICR/L0015-2525K-75-100-FG24-3		3	15	75	100	30	25	22	4.9
ICR/L0015-2525K-100-140-FG24-3		3	15	100	140	30	25	22	4.9
ICR/L0015-2525K-140-200-FG24-3		3	15	140	200	30	25	22	4.9
ICR/L0015-2525K-40-50-FG24-4	FG24	4	15	40	50	30	25	22	4.9
ICR/L0015-2525K-50-60-FG24-4		4	15	50	60	30	25	22	4.9
ICR/L0015-2525K-60-70-FG24-4		4	15	60	75	30	25	22	4.9
ICR/L0015-2525K-75-100-FG24-4		4	15	75	100	30	25	22	4.9
ICR/L0015-2525K-100-140-FG24-4		4	15	100	140	30	25	22	4.9
ICR/L0015-2525K-140-200-FG24-4		4	15	140	200	30	25	22	4.9

Module Holder / Модульные державки

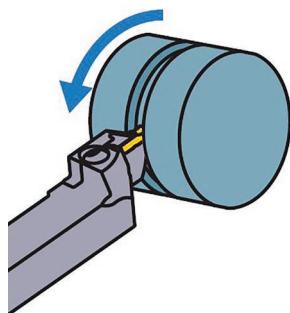

0°



ART. APT.	Cartridge Картридж	Размер хвостовика h	Размер хвостовика h ₁
THR/L-2020x00-IC20	IC20	20	20
THR/L-2525x00-IC20	IC25	25	25

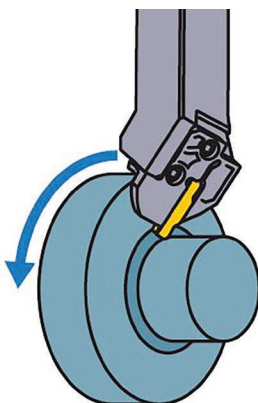

45°



ART. APT.	Cartridge Картридж	Размер хвостовика h	Размер хвостовика h ₁
THR/L-2020x45-IC20	IC20	20	20
THR/L-2525x45-IC20	IC25	25	25

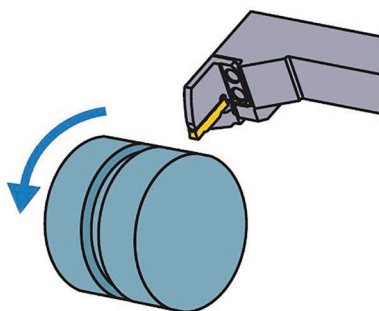



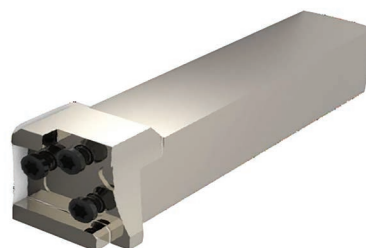

90°

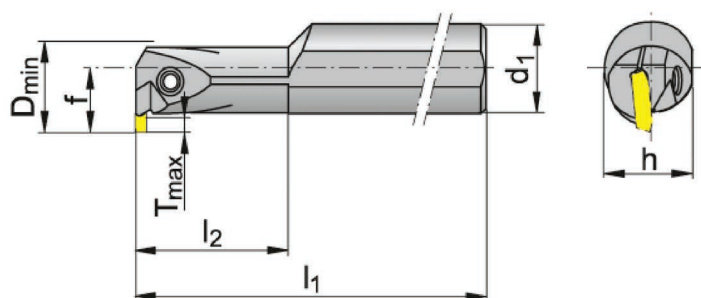

ART. APT.	Cartridge Картридж	Размер хвостовика h	Размер хвостовика h ₁
THR/L-2020x90-IC20	IC20	20	20
THR/L-2525x90-IC20	IC25	25	25

Internal grooving / Внутренняя канавка



ART. APT.	Insert type. Тип пластины	S	T _{max} (mm)	da	L ₂	h	D _{min}	L ₁	f			
S25S GINR/L-008-WD24-02	WD24	2	8	25	52	24.4	32	200	21	195069	1338306	220985
S25S GINR/L-009-WD24-03		3	9	25	52	24.5	32	200	22	195069	1338306	220985
S32S GINR/L-011-WD24-03		3	11	32	64	31	42	250	27.5	195069	1338306	220985
S32S GINR/L-011-WD24-04		4	11	32	64	31	42	250	27.5	195069	1338306	220985
S40T GINR/L-012-WD24-04		4	12	40	80	38.5	53	300	32.5	195069	1338306	220985
S40T GINR/L-012-WD24-05		5	12	40	80	38.5	53	300	32.5	195069	1338306	220985

Blades for parting off / Отрезные ножи

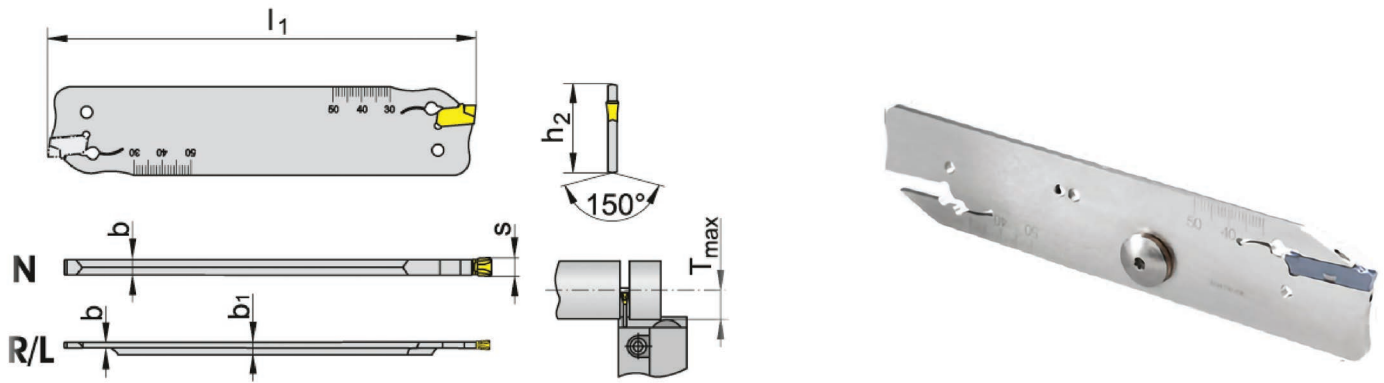



ART. APT.	Insert type. Тип пластины	T _{max} (mm)	h ₂	L	h ₁	S	
ER/L-2602-WF24N-02	WF24/WD24	25	26	110	21.4	2.0	WN-3
ER/L-3202-WF24N-02		25	32	150	25.0	2.0	WN-3
EN-2602-WF24N-02		25	26	110	21.4	2.0	WN-3
EN-3202-WF24N-02		25	32	150	25.0	2.0	WN-3
EN-2603-WF24N-03		35	26	110	21.4	3.0	WN-3
EN-3203-WF24N-03		50	32	150	25.0	3.0	WN-3
EN-2604-WF24N-04		35	26	110	21.4	4.0	WN-4
EN-3204-WF24N-04		50	32	150	25.0	4.0	WN-4
EN-3205-WF24N-05		60	32	150	25.0	5.0	WN-4
EN-3206-WF24N-06		60	32	150	25.0	6.0	WN-4
ER/L-2602-WSN-02	WSN	25	26	110	21.4	2.0	WN-3
ER/L-3202-WSN-02		25	32	150	25.0	2.0	WN-3
EN-2603-WSN-03		35	26	110	21.4	3.0	WN-3
EN-3203-WSN-03		50	32	150	25.0	3.0	WN-3
EN-2604-WSN-04		40	26	110	21.4	4.0	WN-4
EN-3204-WSN-04		50	32	150	25.0	4.0	WN-4
EN-3205-WSN-05		55	32	150	25.0	5.0	WN-4
EN-3206-WSN-06		60	32	150	25.0	6.0	WN-4

IC-Internal coolant / С внутренним пододом СОЖ

ART. APT.	Insert type. Тип пластины	T _{max} (mm)	h	L	h ₁	B	
EN-2602-WF24N-02-IC	WD24/WD24	25	26	110	25.0	2.0	WN-3
EN-3202-WF24N-02-IC		25	32	150	25.0	2.0	WN-3
EN-2603-WF24N-03-IC		35	26	110	21.4	3.0	WN-3
EN-3203-WF24N-03-IC		50	32	150	25.0	3.0	WN-3
ER/L-2602-WSN-02-IC	WSN	25	26	110	21.4	2.0	WN-3
ER/L-3202-WSN-02-IC		25	32	150	25.0	2.0	WN-3
EN-2603-WSN-03-IC		35	26	110	21.4	3.0	WN-3
EN-3203-WSN-03-IC		50	32	150	25.0	3.0	WN-3
EN-2604-WSN-04-IC		40	32	110	21.4	4.0	WN-4
EN-3204-WSN-04-IC		50	32	150	25.0	4.0	WN-4

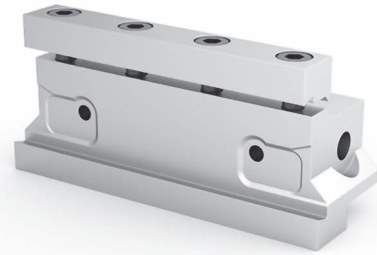
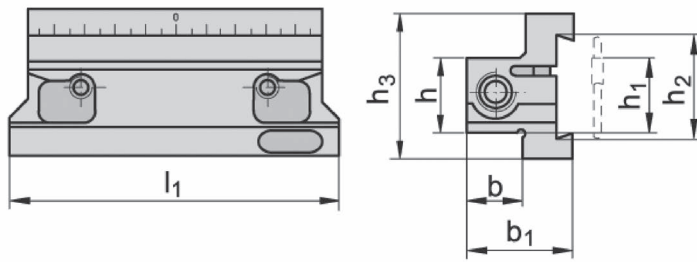

Clamping block / Зажимные блоки отрезных ножей

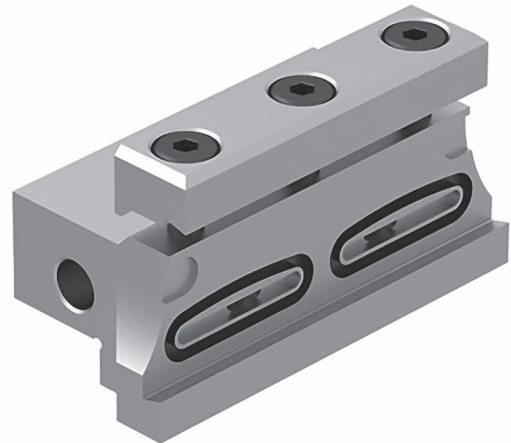
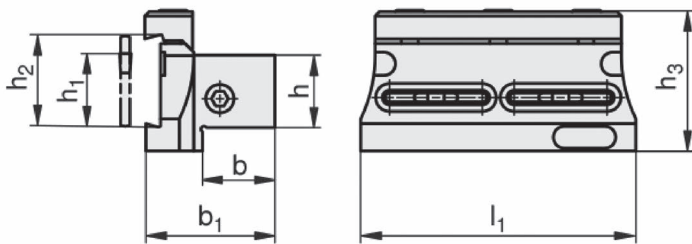

ART. APT.	Blade type. Тип ножей	h_1	L	h	b	 Kg	
END 2620	EN26	26	87	20	20	0,550	22485
END 3225	EN32	32	110	25	25	1,000	22485





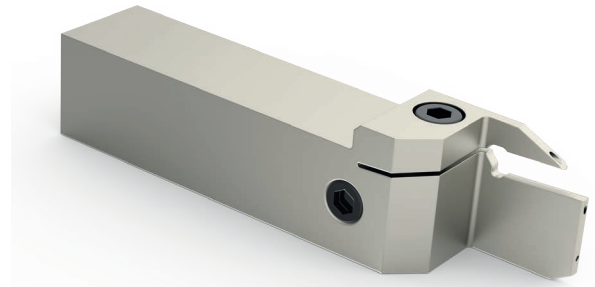
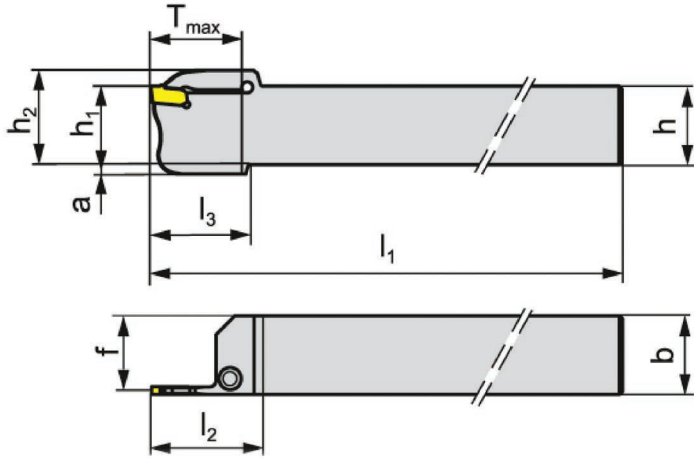

IC-Internal coolant / С внутренним подводом СОЖ

ART. APT.	Blade type. Тип ножей	h_1	L	h	b	 Kg		
END 2620-IC	EN26	26	82	20	20	0,550	11776816	11960993
END 3225-IC	EN32	32	95	25	25	1,000	11776816	11960993

Toolholders with cooling / Державки с внутренним подводом СОЖ



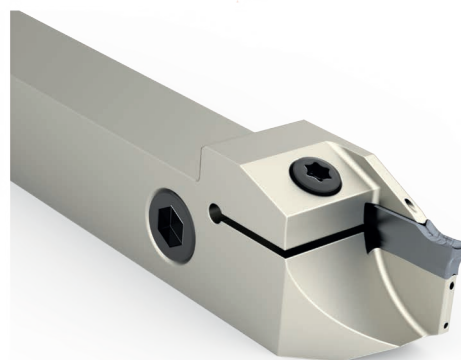
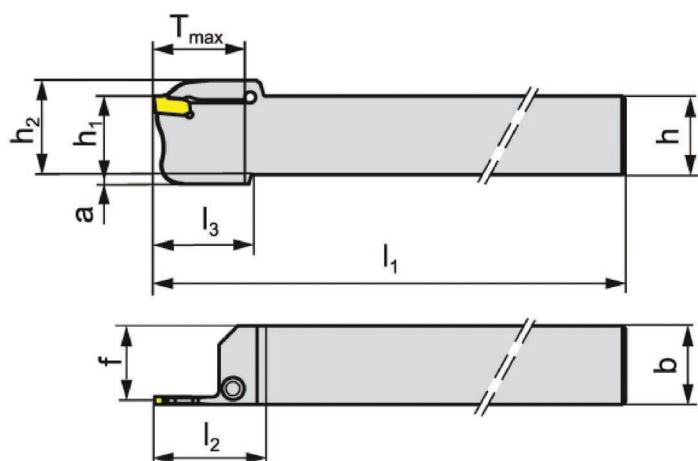

Right hand / Изображена правая державка

ART. APT.	Insert type. Тип пластины	W	$T_{max}(mm)$	$h=h_1$	b	L_1				
		2	13	12	12	125	4493	4496	11040843	12089802
E16R/L0013-1616K-WD24-2-IC	WD24/WF24	2	13	16	16	125	4493	4496	11040843	12089802
E20R/L0013-2020K-WD24-2-IC		2	13	20	20	125	4493	4496	11040843	12089802
E16R/L0025-1616K-WD24-3-IC		3	25	16	16	125	4493	4496	11040843	12089802
E20R/L0025-2020K-WD24-3-IC		3	25	20	20	125	4493	4496	11040843	12089802
E25R/L0025-2525K-WD24-3-IC	WD24/WF24	3	25	25	25	125	4493	4496	11040843	12089802
E32R/L0025-3232P-WD24-3-IC		3	25	32	32	170	4493	4496	11040843	12089802
E40R/L0025-4040S-WD24-3-IC		3	25	40	40	250	4493	4496	11040843	12089802
E16R/L0025-1616K-WD24-4-IC		4	25	16	16	125	4493	4496	11040843	12089802
E20R/L0025-2020K-WD24-4-IC		4	25	20	20	125	4493	4496	11040843	12089802
E25R/L0025-2525K-WD24-4-IC	WD24/WF24	4	25	25	25	125	4493	4496	11040843	12089802
E32R/L0025-3232P-WD24-4-IC		4	25	32	32	170	4493	4496	11040843	12089802
E32R/L0025-3232S-WD24-4-IC		4	25	40	40	250	4493	4496	11040843	12089802
E20R/L0025-2020K-WD24-5-IC	WD24/WF24	5	25	20	20	125	4493	4496	11040843	12089802
E25R/L0025-2525K-WD24-5-IC		5	25	25	25	125	4493	4496	11040843	12089802
E20R/L0025-2020K-WD24-6-IC	WD24/WF24	6	25	20	20	125	4493	4496	11040843	12089802
E25R/L0025-2525K-WD24-6-IC		6	25	25	25	125	4493	4496	11040843	12089802
E40R/L0032-4040P-WD35-8-IC	WD35	8	32	40	40	170	4493	4496	11040843	12089802



Right hand / Изображена правая державка

ART. APT.	Insert type. Тип пластины	W	$T_{max}(mm)$	h	h_1	L_1		
RCE12R/L0013-1212K-WD24-2-IC	WD24/WF24	2	13	12	12	125	195068	12380791
RCE16R/L0013-1616K-WD24-2-IC		2	13	16	16	125	195068	12380791
RCE16R/L0021-1616K-WD24-2-IC	WD24 / WF24	2	21	16	16	125	195068	12380793
RCE12R/L0013-1212K-WD24-3-IC	WD24 / WF24	3	13	12	12	125	195068	12380793
RCE16R/L0013-1616K-WD24-3-IC		3	13	16	16	125	195068	12380793
RCE16R/L0021-1616K-WD24-3-IC	WD24 / WF24	3	21	16	16	125	195068	12380791

Blank page with horizontal dotted lines for writing.



TOOLS WITH CARBIDE INSERTS
ИНСТРУМЕНТ СО СМЕННЫМИ ТВЕРДОСПЛАВНЫМИ ПЛАСТИНАМИ

THREADING INSERTS
РЕЗЬБОНАРЕЗНЫЕ ПЛАСТИНЫ

TABLE OF CONTENTS / СОДЕРЖАНИЕ

SOLID CARBIDE TOOLS

ТВЕРДОСПЛАВНЫЙ ИНСТРУМЕНТ

1	Carbide mills Твердосплавные фрезы	3
2	Carbide drills Твердосплавные сверла	5
3	Special tools Специальные инструменты	39

TOOLS WITH CARBIDE INSERTS

ИНСТРУМЕНТ СО СМЕННЫМИ ТВЕРДОСПЛАВНЫМИ ПЛАСТИНАМИ

4	Turning carbide inserts Токарные твердосплавные пластины	49
5	Toolholders for external turning Токарные державки для наружной обработки	54
6	Toolholders for internal turning Токарные державки для внутренней обработки	55
7	Grooving and parting off Канавка и отрезка	91
8	Threading inserts Резьбонарезные пластины	123
○	Alloy description Описание сплавов	143
○	Partial profile 60°/55° Неполный профиль 60°/55°	175
○	ISO - metric ISO - метрическая	177
○	UN - Unified UN - Унифицированная	181
○	Whitworth 55° Витворта 55°	184
○	NPT NPT	187
○	NPTF NPTF	191
○	BSPT BSPT	195
○	Acme Acme	196
○	Stub Acme Acme	199
○	Trapezoidal Трапецеидальная	200
○	PG - DIN 40430/Thrust thread - DIN 513 PG - DIN 40430/Упорная резьба - DIN 513	201
○	Round Круглая резьба	202
○	UNJ UNJ	203
○	MJ MJ	204
○	Buttress Американская Buttress	207
○	OIL Threads Резьба по нефтяному стандарту API	209
○	Extreme - Line Casing Трапецеидальная резьба для обсадных труб	210
○	Buttress Casing Buttress для обсадных труб	214
○	Cutting speed Режимы резания.	217
○	Recommendations for use Рекомендации к применению	271
○	Toolholders Державки	214
9	Milling with carbide inserts Фрезы со сменными твердосплавными пластинами	217
10	Drills with carbide inserts Сверла со сменными пластинами	271

Coated alloys Сплавы с покрытием

HS2020

Extra-fine sub-micron grade with high toughness, for optimized performance on hardened steels and cast iron up to 62HRC, titanium alloys and super alloys (hastelloy, inconel and nickel based alloys). (on request)

Особо мелкозернистый твердый сплав с высокой прочностью, для оптимальной обработки закаленных сталей и чугуна твердостью до 62HRC, титановых жаропрочных сплавов (Hastel-loy, Inconel сплавов на основе никеля). (по запросу)

MS1515

PVD triple layer coated sub-micron grade for stainless steels, cast iron, titanium, non ferrous metals and most of the high temperature alloys. (on request)

Особо мелкозернистый твердый сплав с многослойным PVD покрытием для обработки нержавеющей стали, чугуна, титана, цветных металлов и большинства высокотемпературных сплавов. (по запросу)

PK3025

PVD TiAlN coated sub-micrograin grade for stainless steels and exotic materials at medium to high cutting speeds. (First choice)

Особо мелкозернистый твердый сплав с покрытием TiAlN (методом PVD) для обработки нержавеющей стали и необычных материалов на средних и высоких скоростях. (первый выбор)

Uncoated alloys Сплавы без покрытия

N20K

Carbide grade for non ferrous metals, aluminum and cast iron. on request

Твердый сплав для обработки цветных металлов, алюминия и чугуна. (по запросу)

Grade availability per inserts size Размеры пластин выполняемых из сплавов

Alloy/Сплав	HS2020	MS1515	PK3025	N20K
Insert sizes/ Размеры пластин	11, 16, 22, 27	11, 16, 22	06, 08, 11, 16, 22, 27, 33U,	06, 08, 11, 16, 22, 27, 33U

Partial profile 60° / Неполный профиль 60°

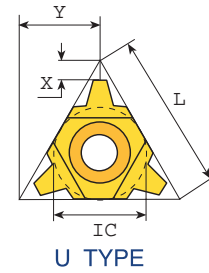
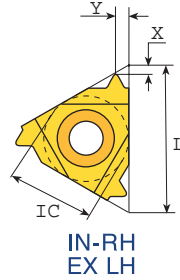
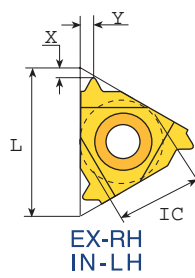
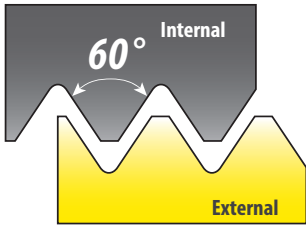

Designation/Обозначение				Dimensions/Размеры				Pitch/Шаг		Grades / Сплавы			
External/Внешняя		Internal/Внутренняя								PK3025	MS1515	N20K	HS2020
RH	LH	RH	LH	X	Y	L	I.C. дюйм	mm	TPI	PK3025	MS1515	N20K	HS2020
11 ER A60	11 EL A60	11 IR A60	11 IL A60	0.8	0.9	11	1/4	0.5-1.5	48-16	●	○	○	○
16 ER A60	16 EL A60	16 IR A60	16 IL A60	0.8	0.9	16	3/8	0.5-1.5	48-16	●	○	○	○
16 ER G60	16 EL G60	16 IR G60	16 IL G60	1.2	1.7	16	3/8	1.75-3.0	14-8	●	○	○	○
16 ER AG60	16 EL AG60	16 IR AG60	16 IL AG60	1.2	1.7	16	3/8	0.5 -3.0	48-8	●	○	○	○
22 ER N60	22 EL N60	22 IR N60	22 IL N60	1.7	2.5	22	1/2	3.5-5.0	7-5	●	○	○	○
27 ER Q60	27 EL Q60	27 IR Q60	27 IL Q60	2.1	3.1	27	5/8	5.5-6.0	4.5-4	●		○	○
P Steel - Сталь										★			
M Stainless steel aust. - Аустенитная нерж. сталь										★	★		
K Cast iron - Чугун										★		☆	
N Aluminium - Алюминиевые сплавы										★	★	★	
S Hig. temp. alloy - Жаропрочные сплавы										★	★		★
H Hardened steel - Закаленные стали													★



p. 214



p.215

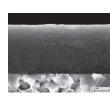

p.177

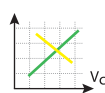

p. 211

Partial profile 55° / Неполный профиль 55°

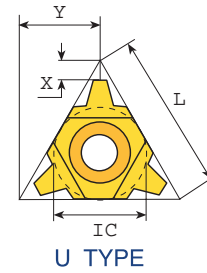
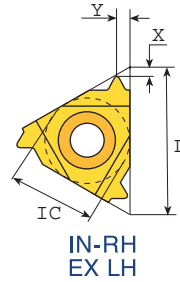
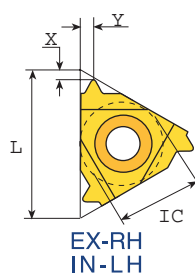
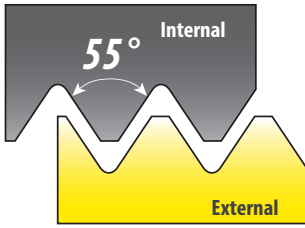

Designation/Обозначение				Dimensions/Размеры				Pitch/Шар		Grades / Сплавы			
External/Внешняя		Internal/Внутренняя								PK3025	MS1515	N20K	HS2020
RH	LH	RH	LH	X	Y	L	I.C. дюйм	mm	TPI				
11 ER A55	11 EL A55	11 IR A55	11 IL A55	0.8	0.9	11	1/4	0.5-1.5	48-16	●	○	○	○
16 ER A55	16 EL A55	16 IR A55	16 IL A55	0.8	0.9	16	3/8	0.5-1.5	48-16	●	○	○	○
16 ER G55	16 EL G55	16 IR G55	16 IL G55	1.2	1.7	16	3/8	1.75-3.0	14-8	●	○	○	○
16 ER AG55	16 EL AG55	16 IR AG55	16 IL AG55	1.2	1.7	16	3/8	0.5-3.0	48-8	●	○	○	○
22 ER N55	22 EL N55	22 IR N55	22 IL N55	1.7	2.5	22	1/2	3.5-5.0	7-5	●	○	○	○
27 ER Q55	27 EL Q55	27 IR Q55	27 IL Q55	2.0	2.9	27	5/8	5.5-6.0	4.5-4	●		○	○
P Steel - Сталь										★			
M Stainless steel aust. - Аустенитная нерж. сталь										★	★		
K Cast iron - Чугун										★		☆	
N Aluminium - Алюминиевые сплавы										★	★	★	
S Hig. temp. alloy - Жаропрочные сплавы										★	★		★
H Hardened steel - Закаленные стали													★



p. 214



p. 215

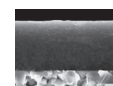

p. 177

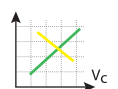

p. 211

Partial profile 60° / Неполный профиль 60°

Vertical 60°

Вертикальная 60°

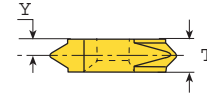
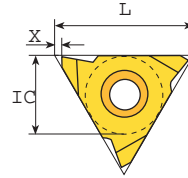
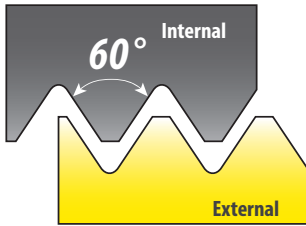

Designation/Обозначение				Dimensions/Размеры					Pitch/Шаг		Grades / Сплавы			
External/Внешняя		Internal/Внутренняя									PK3025	MS1515	N20K	HS2020
RH	LH	RH	LH	X	Y	T	L	I.C. дюйм	mm	TPI				
16V ER A60				1.0	0.9	3.6	16	3/8	0.5-1.5	48-16	●	○	○	○
16V ER G60				1.0	1.8	3.6	16	3/8	1.75-3.0	14-8	●	○	○	○
16V ER AG60				1.0	1.8	3.6	16	3/8	0.5-3.0	48-8	●	○	○	○

Vertical 55°

Вертикальная 55°

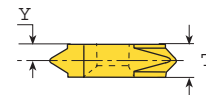
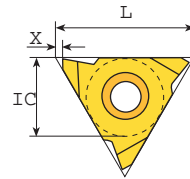

Designation/Обозначение				Dimensions/Размеры					Pitch/Шаг		Grades / Сплавы			
External/Внешняя		Internal/Внутренняя									PK3025	MS1515	N20K	HS2020
RH	LH	RH	LH	X	Y	T	L	I.C. дюйм	mm	TPI				
16V ER A55				1.0	0.9	3.6	16	3/8	0.5-1.5	48-16	●	○	○	○
16V ER G55				1.0	1.7	3.6	16	3/8	1.75-3.0	14-8	●	○	○	○
16V ER AG55				1.0	1.8	3.6	16	3/8	0.5-3.0	48-8	●	○	○	○

P Steel - Сталь	★													
M Stainless steel aust. - Аустенитная нерж. сталь	★	★												
K Cast iron - Чугун	★		☆											
N Aluminium - Алюминиевые сплавы	★	★	★											
S Hig. temp. alloy - Жаропрочные сплавы	★	★												★
H Hardened steel - Закаленные стали														★



p. 214



p. 215

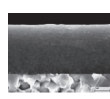

p. 177

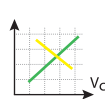

p. 211

ISO - metric/ ISO - метрическая

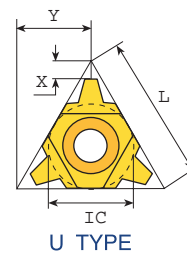
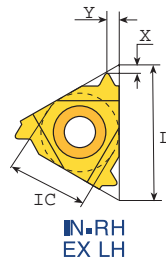
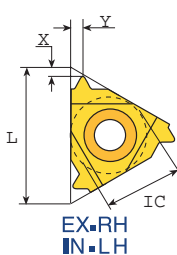
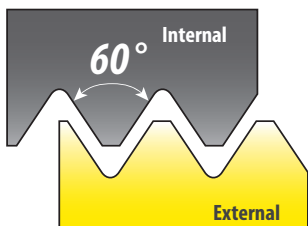

		Designation/Обозначение				Dimensions/Размеры					Pitch/Шар	Grades / Сплавы			
		External/Внешняя		Internal/Внутренняя											
X	Y	RH	LH	RH	LH	X	Y	L	I.C. дюйм	mm	PK3025	MS1515	N20K	HS2020	
				06 IR 0.5 ISO	06 IL 0.5 ISO	0.9	0.5	6	5/32	0.5	●		○		
				06 IR 0.75 ISO	06 IL 0.75 ISO	0.8	0.5	6	5/32	0.75	●		○		
				06 IR 1.0 ISO	06 IL 1.0 ISO	0.7	0.6	6	5/32	1.0	●		○		
				06 IR 1.25 ISO	06 IL 1.25 ISO	0.6	0.6	6	5/32	1.25	●		○		
				08 IR 0.5 ISO	08 IL 0.5 ISO	0.6	0.5	8	3/16	0.5	●		○		
				08 IR 0.75 ISO	08 IL 0.75 ISO	0.6	0.5	8	3/16	0.75	●		○		
				08 IR 1.0 ISO	08 IL 1.0 ISO	0.6	0.6	8	3/16	1.0	●		○		
				08 IR 1.25 ISO	08 IL 1.25 ISO	0.6	0.7	8	3/16	1.25	●		○		
				08 IR 1.5 ISO	08 IL 1.5 ISO	0.6	0.7	8	3/16	1.5	●		○		
				08 IR 1.75 ISO	08 IL 1.75 ISO	0.6	0.8	8	3/16	1.75	●		○		
0.8	0.4	11 ER 0.35 ISO	11 EL 0.35 ISO	11 IR 0.35 ISO	11 IL 0.35 ISO	0.8	0.3	11	1/4	0.35	●	○	○	○	
0.7	0.4	11 ER 0.4 ISO	11 EL 0.4 ISO	11 IR 0.4 ISO	11 IL 0.4 ISO	0.8	0.4	11	1/4	0.4	●	○	○	○	
0.7	0.4	11 ER 0.45 ISO	11 EL 0.45 ISO	11 IR 0.45 ISO	11 IL 0.45 ISO	0.8	0.4	11	1/4	0.45	●	○	○	○	
0.6	0.6	11 ER 0.5 ISO	11 EL 0.5 ISO	11 IR 0.5 ISO	11 IL 0.5 ISO	0.6	0.6	11	1/4	0.5	●	○	○	○	
0.6	0.6	11 ER 0.6 ISO	11 EL 0.6 ISO	11 IR 0.6 ISO	11 IL 0.6 ISO	0.6	0.6	11	1/4	0.6	●	○	○	○	
0.6	0.6	11 ER 0.7 ISO	11 EL 0.7 ISO	11 IR 0.7 ISO	11 IL 0.7 ISO	0.6	0.6	11	1/4	0.7	●	○	○	○	
0.6	0.6	11 ER 0.75 ISO	11 EL 0.75 ISO	11 IR 0.75 ISO	11 IL 0.75 ISO	0.6	0.6	11	1/4	0.75	●	○	○	○	
0.6	0.6	11 ER 0.8 ISO	11 EL 0.8 ISO	11 IR 0.8 ISO	11 IL 0.8 ISO	0.6	0.6	11	1/4	0.8	●	○	○	○	
0.7	0.7	11 ER 1.0 ISO	11 EL 1.0 ISO	11 IR 1.0 ISO	11 IL 1.0 ISO	0.6	0.7	11	1/4	1.0	●	○	○	○	
0.8	0.9	11 ER 1.25 ISO	11 EL 1.25 ISO	11 IR 1.25 ISO	11 IL 1.25 ISO	0.8	0.8	11	1/4	1.25	●	○	○	○	
0.8	1.0	11 ER 1.5 ISO	11 EL 1.5 ISO	11 IR 1.5 ISO	11 IL 1.5 ISO	0.8	1.0	11	1/4	1.5	●	○	○	○	
0.8	1.1	11 ER 1.75 ISO	11 EL 1.75 ISO	11 IR 1.75 ISO	11 IL 1.75 ISO	0.8	1.1	11	1/4	1.75	●	○	○	○	
0.8	1.1	11 ER 2.0 ISO	11 EL 2.0 ISO	11 IR 2.0 ISO	11 IL 2.0 ISO	0.8	0.9	11	1/4	2.0	●	○	○	○	
											PK3025	MS1515	N20K	HS2020	
P Steel - Сталь											★				
M Stainless steel aust. - Аустенитная нерж. сталь											★	★			
K Cast iron - Чугун											★		☆		
N Aluminium - Алюминиевые сплавы											★	★	★		
S Hig. temp. alloy - Жаропрочные сплавы											★	★		★	
H Hardened steel - Закаленные стали														★	



p. 214



p. 215

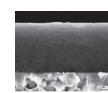

p. 177

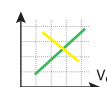

p. 211

Multitooth Многозубые пластины

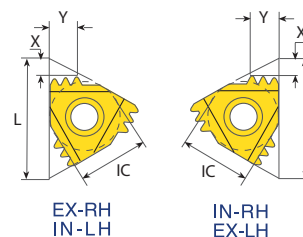
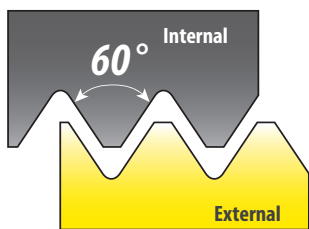

Designation/Обозначение				Dimensions/Размеры				Pitch, мм Шаг,мм	No. of teeth/ Кол-во зубьев	Grades / Сплавы			
External/Внешняя		Internal/Внутренняя		X	Y	L	И.С. дюйм			PK3025	MS1515	N20K	HS2020
16 ER 1.0 ISO 3M	ES16M	16 IR 1.0 ISO 3M	IS16M	1.7	2.5	16	3/8	0.5	3	●	○	○	○
16 ER 1.5 ISO 2M	ES16M	16 IR 1.5 ISO 2M	IS16M	1.5	2.3	16	3/8	0.75	2	●	○	○	○
22 ER 1.5 ISO 3M	ES22M	22 IR 1.5 ISO 3M	IS22M	2.3	3.7	22	1/2	0.8	3	●	○	○	○
22 ER 2.0 ISO 2M	ES22M	22 IR 2.0 ISO 2M	IS22M	2.0	3.0	22	1/2	1.0	2	●	○	○	○
22 ER 2.0 ISO 3M	ES22M	22 IR 2.0 ISO 3M	IS22M	3.1	5.0	22	1/2	1.25	3	●	○	○	○
27 ER 3.0 ISO 2M	ES27M	27 IR 3.0 ISO 2M	IS27M	2.9	4.6	27	5/8	1.5	2	●		○	○

ISO - metric / ISO - метрическая

Vertical Вертикальная

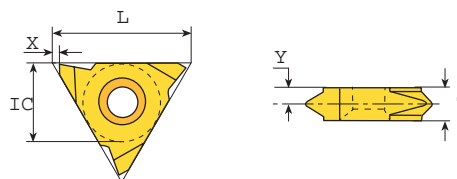

Designation/Обозначение				Dimensions/Размеры					Pitch, mm Шаг,мм	Grades / Сплавы			
External/Внешняя		Internal/Внутренняя		X	Y	T	L	И.С. дюйм		PK3025	MS1515	N20K	HS2020
										●			
16V ER 1.0 ISO				1.0	0.7	3.6	16	3/8	1.0	●	○		○
16V ER 1.25 ISO				1.0	0.9	3.6	16	3/8	1.25	●	○		○
16V ER 1.5 ISO				1.0	0.9	3.6	16	3/8	1.5	●	○		○
16V ER 2.0 ISO				1.0	1.3	3.6	16	3/8	2.0	●	○		○

P Steel - Сталь	★			
M Stainless steel aust. - Аустенитная нерж. сталь	★	★		
K Cast iron - Чугун	★		☆	
N Aluminium - Алюминиевые сплавы	★	★	★	
S Hig. temp. alloy - Жаропрочные сплавы	★	★		★
H Hardened steel - Закаленные стали				★



p. 214



p. 215

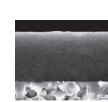

p. 177

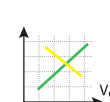

p. 211

UN - Unified / унифицированная UNC, UNF, UNEF, UNS

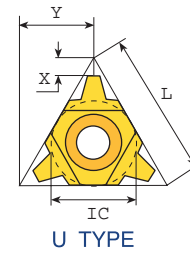
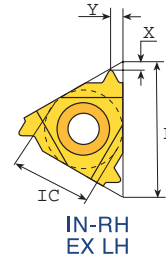
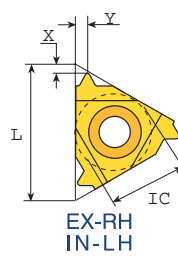
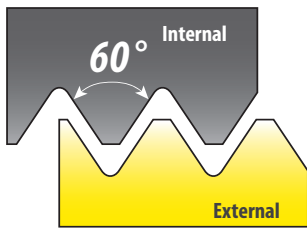

X	Y	Designation/Обозначение				Dimensions/Размеры				TPI ниток/ дюйм	Grades / Сплавы			
		External/Внешняя		Internal/Внутренняя		X	Y	L	I.C. дюйм		PK3025	MS1515	N20K	HS2020
		RH	LH	RH	LH									
				06 IR 32 UN	06 IL 32 UN	0.8	0.5	6	5/32	32	●		○	
				06 IR 28 UN	06 IL 28 UN	0.8	0.6	6	5/32	28	●		○	
				06 IR 24 UN	06 IL 24 UN	0.7	0.6	6	5/32	24	●		○	
				06 IR 20 UN	06 IL 20 UN	0.6	0.6	6	5/32	20	●		○	
				06 IR 18 UN	06 IL 18 UN	0.6	0.7	8	5/32	18	●		○	
				08 IR 32 UN	08 IL 32 UN	0.6	0.5	8	3/16	32	●		○	
				08 IR 28 UN	08 IL 28 UN	0.6	0.6	8	3/16	28	●		○	
				08 IR 24 UN	08 IL 24 UN	0.6	0.6	8	3/16	24	●		○	
				08 IR 20 UN	08 IL 20 UN	0.6	0.7	8	3/16	20	●		○	
				08 IR 18 UN	08 IL 18 UN	0.6	0.7	8	3/16	18	●		○	
				08 IR 16 UN	08 IL 16 UN	0.6	0.7	8	3/16	16	●		○	
				08 IR 14 UN	08 IL 14 UN	0.6	0.8	8	3/16	14	●		○	
0.6	0.6	11 ER 72 UN	11 EL 72 UN	11 IR 72 UN	11 IL 72 UN	0.8	0.3	11	1/4	72	●	○	○	○
0.6	0.6	11 ER 64 UN	11 EL 64 UN	11 IR 64 UN	11 IL 64 UN	0.8	0.4	11	1/4	64	●	○	○	○
0.6	0.6	11 ER 56 UN	11 EL 56 UN	11 IR 56 UN	11 IL 56 UN	0.7	0.4	11	1/4	56	●	○	○	○
0.7	0.7	11 ER 48 UN	11 EL 48 UN	11 IR 48 UN	11 IL 48 UN	0.6	0.6	11	1/4	48	●	○	○	○
0.8	0.9	11 ER 44 UN	11 EL 44 UN	11 IR 44 UN	11 IL 44 UN	0.6	0.6	11	1/4	44	●	○	○	○
0.8	1.0	11 ER 40 UN	11 EL 40 UN	11 IR 40 UN	11 IL 40 UN	0.6	0.6	11	1/4	40	●	○	○	○
0.8	1.1	11 ER 36 UN	11 EL 36 UN	11 IR 36 UN	11 IL 36 UN	0.6	0.6	11	1/4	36	●	○	○	○
P Steel - Сталь											★			
M Stainless steel aust. - Аустенитная нерж. сталь											★	★		
K Cast iron- Чугун											★		☆	
N Aluminium - Алюминиевые сплавы											★	★	★	
S Hig. temp. alloy - Жаропрочные сплавы											★	★		★
H Hardened steel - Закаленные стали														★



p.214



p.215

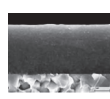

p.177

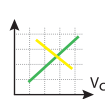

p.211

UN - Unified / унифицированная UNC, UNF, UNEF, UNS

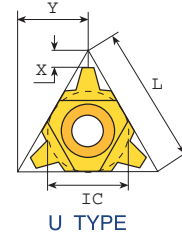
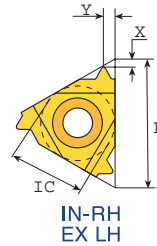
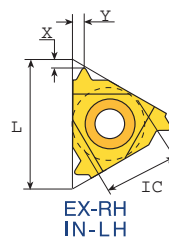
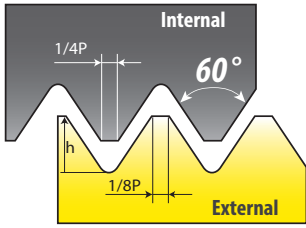

X	Y	Designation/Обозначение				Dimensions/Размеры				TPI ниток/ дюйм	Grades / Сплавы				
		External/Внешняя		Internal/Внутренняя		X	Y	L	I.C. дюйм		PK3025	M51515	N20K	H52020	
		RH	LH	RH	LH										
0.6	0.6	16 ER 32 UN	16 EL 32 UN	16 IR 32 UN	16 IL 32 UN	0.6	0.6	16	3/8	32	●	○	○	○	
0.6	0.7	16 ER 28 UN	16 EL 28 UN	16 IR 28 UN	16 IL 28 UN	0.6	0.7	16	3/8	28	●	○	○	○	
0.7	0.8	16 ER 27 UN	16 EL 27 UN	16 IR 27 UN	16 IL 27 UN	0.7	0.8	16	3/8	27	●	○	○	○	
0.7	0.8	16 ER 24 UN	16 EL 24 UN	16 IR 24 UN	16 IL 24 UN	0.7	0.8	16	3/8	24	●	○	○	○	
0.8	0.9	16 ER 20 UN	16 EL 20 UN	16 IR 20 UN	16 IL 20 UN	0.8	0.9	16	3/8	20	●	○	○	○	
0.8	1.0	16 ER 18 UN	16 EL 18 UN	16 IR 18 UN	16 IL 18 UN	0.8	1.0	16	3/8	18	●	○	○	○	
0.9	1.1	16 ER 16 UN	16 EL 16 UN	16 IR 16 UN	16 IL 16 UN	0.9	1.1	16	3/8	16	●	○	○	○	
1.0	1.2	16 ER 14 UN	16 EL 14 UN	16 IR 14 UN	16 IL 14 UN	0.9	1.2	16	3/8	14	●	○	○	○	
1.0	1.3	16 ER 13 UN	16 EL 13 UN	16 IR 13 UN	16 IL 13 UN	1.0	1.3	16	3/8	13	●	○	○	○	
1.1	1.4	16 ER 12 UN	16 EL 12 UN	16 IR 12 UN	16 IL 12 UN	1.1	1.4	16	3/8	12	●	○	○	○	
1.1	1.5	16 ER 11 UN	16 EL 11 UN	16 IR 11 UN	16 IL 11 UN	1.1	1.5	16	3/8	11	●	○	○	○	
1.1	1.5	16 ER 10 UN	16 EL 10 UN	16 IR 10 UN	16 IL 10 UN	1.1	1.5	16	3/8	10	●	○	○	○	
1.2	1.7	16 ER 9 UN	16 EL 9 UN	16 IR 9 UN	16 IL 9 UN	1.2	1.7	16	3/8	9	●	○	○	○	
1.2	1.6	16 ER 8 UN	16 EL 8 UN	16 IR 8 UN	16 IL 8 UN	1.1	1.5	16	3/8	8	●	○	○	○	
1.6	2.3	22 ER 7 UN	22 EL 7 UN	22 IR 7 UN	22 IL 7 UN	1.6	2.3	22	1/2	7	●	○	○	○	
1.6	2.3	22 ER 6 UN	22 EL 6 UN	22 IR 6 UN	22 IL 6 UN	1.6	2.3	22	1/2	6	●	○	○	○	
1.7	2.5	22 ER 5 UN	22 EL 5 UN	22 IR 5 UN	22 IL 5 UN	1.6	2.3	22	1/2	5	●	○	○	○	
1.9	2.7	27 ER 4.5 UN	27 EL 4.5 UN	27 IR 4.5 UN	27 IL 4.5 UN	1.7	2.4	27	5/8	4.5	●		○	○	
2.1	3.0	27 ER 4 UN	27 EL 4 UN	27 IR 4 UN	27 IL 4 UN	1.8	2.7	27	5/8	4	●		○	○	
												PK3025	M51515	N20K	H52020
P Steel - Сталь											★				
M Stainless steel aust. - Аустенитная нерж. сталь											★	★			
K Cast iron - Чугун											★		☆		
N Aluminium - Алюминиевые сплавы											★	★	★		
S Hig. temp. alloy - Жаропрочные сплавы											★	★		★	
H Hardened steel - Закаленные стали														★	



p. 214



p. 215

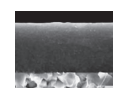

p. 177

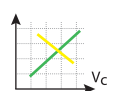

p. 211

UN - Unified / унифицированная

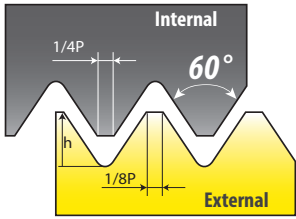

Multitooth
Многозубые пластины

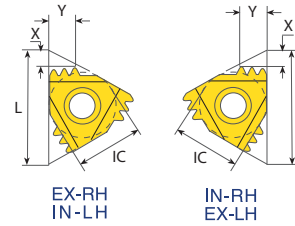

Designation/Обозначение				Dimensions/Размеры				TPI ниток/ дюйм	No. of teeth/ Кол-во зубьев	Grades / Сплавы			
External/Внешняя		Internal/Внутренняя		X	Y	L	И.С. дюйм			PK3025	MS1515	N20K	HS2020
	Опорная пластина		Опорная пластина										
16 ER 20 UN 2M	ES16M	16 IR 20 UN 2M	IS16M	1.4	2.0	16	3/8	20	2	●	○	○	○
16 ER 16 UN 2M	ES16M	16 IR 16 UN 2M	IS16M	1.5	2.3	16	3/8	16	2	●	○	○	○
16 ER 14 UN 2M	ES16M	16 IR 14 UN 2M	IS16M	1.7	2.7	16	3/8	14	2	●	○	○	○
16 ER 12 UN 2M	ES16M	16 IR 12 UN 2M	IS16M	2.0	3.1	16	3/8	12	2	●	○	○	○
22 ER 12 UN 2M	ES22M	22 IR 12 UN 2M	IS22M	2.2	3.4	22	1/2	12	3	●	○	○	○
22 ER 12 UN 3M	ES22M	22 IR 12 UN 3M	IS22M	3.3	5.3	22	1/2	12	3	●	○	○	○
27 ER 8 UN 2M	ES27M	27 IR 8 UN 2M	IS27M	3.1	4.9	27	5/8	8	2	●	○	○	○

Vertical Вертикальная

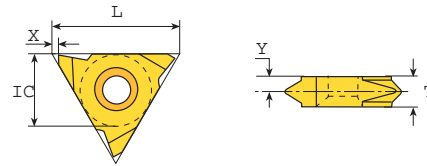

Designation/Обозначение				Dimensions/Размеры					TPI ниток/ дюйм	Grades / Сплавы			
External/Внешняя		Internal/Внутренняя		X	Y	T	L	И.С. дюйм		PK3025	MS1515	N20K	HS2020
RH	LH	RH	LH										
16V ER 20 UN				1.0	0.9	3.6	16	3/8	20	●	○	○	○
16V ER 16 UN				1.0	1.1	3.6	16	3/8	16	●	○	○	○
16V ER 14 UN				1.0	1.2	3.6	16	3/8	14	●	○	○	○
16V ER 12 UN				1.0	1.4	3.6	16	3/8	12	●	○	○	○

	PK3025	MS1515	N20K	HS2020
P Steel - Сталь	★			
M Stainless steel aust. - Аустенитная нерж. сталь	★	★		
K Cast iron - Чугун	★		☆	
N Aluminium - Алюминиевые сплавы	★	★	★	
S Hig. temp. alloy - Жаропрочные сплавы	★	★		★
H Hardened steel - Закаленные стали				★



p. 214



p.215

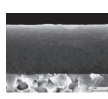

p.177

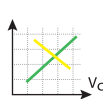

p. 211

Whitworth/Витворта - 55° BSW, BSF, BSP, BSB

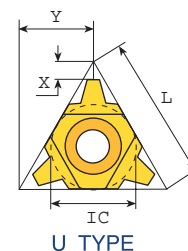
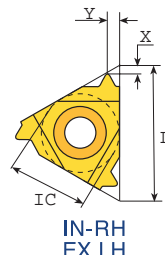
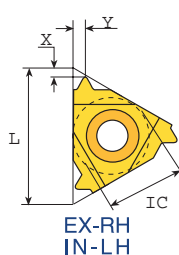
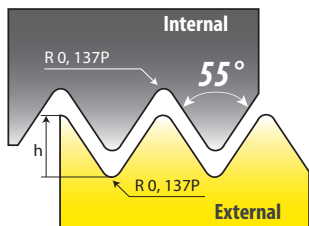

Designation/Обозначение				Dimensions/Размеры				TPI ниток/дюйм	Grades / Сплавы			
External/Внешняя		Internal/Внутренняя		X	Y	L	И.С. дюйм		PK3025	MS1515	N20K	HS2020
RH	LH	RH	LH									
		06 IR 26 W	06 IL 26 W	0.7	0.6	6	5/32	26	●		○	
		06 IR 22 W	06 IL 22 W	0.6	0.6	6	5/32	22	●		○	
		06 IR 18 W	06 IL 18 W	0.6	0.7	6	5/32	18	●		○	
		08 IR 28 W	08 IL 28 W	0.6	0.6	8	3/16	28	●		○	
		08 IR 24 W	08 IL 24 W	0.6	0.6	8	3/16	24	●		○	
		08 IR 20 W	08 IL 20 W	0.6	0.7	8	3/16	20	●		○	
		08 IR 19 W	08 IL 19 W	0.6	0.7	8	3/16	19	●		○	
		08 IR 18 W	08 IL 18 W	0.6	0.7	8	3/16	18	●		○	
		08 IR 16 W	08 IL 16 W	0.6	0.7	8	3/16	16	●		○	
11 ER 72 W	11 EL 72 W	11 IR 72 W	11 IL 72 W	0.7	0.4	11	1/4	72	●	○	○	○
11 ER 60 W	11 EL 60 W	11 IR 60 W	11 IL 60 W	0.7	0.4	11	1/4	60	●	○	○	○
11 ER 56 W	11 EL 56 W	11 IR 56 W	11 IL 56 W	0.7	0.4	11	1/4	56	●	○	○	○
11 ER 48 W	11 EL 48 W	11 IR 48 W	11 IL 48 W	0.6	0.6	11	1/4	48	●	○	○	○
11 ER 40 W	11 EL 40 W	11 IR 40 W	11 IL 40 W	0.6	0.6	11	1/4	40	●	○	○	○
11 ER 36 W	11 EL 36 W			0.6	0.6	11	1/4	36	●	○	○	○
11 ER 32 W	11 EL 32 W	11 IR 32 W	11 IL 32 W	0.6	0.6	11	1/4	32	●	○	○	○
11 ER 28 W	11 EL 28 W	11 IR 28 W	11 IL 28 W	0.6	0.7	11	1/4	28	●	○	○	○
11 ER 26 W	11 EL 26 W	11 IR 26 W	11 IL 26 W	0.7	0.7	11	1/4	26	●	○	○	○
11 ER 24 W	11 EL 24 W	11 IR 24 W	11 IL 24 W	0.7	0.8	11	1/4	24	●	○	○	○
11 ER 22 W	11 EL 22 W			0.8	0.9	11	1/4	22	●	○	○	○
11 ER 20 W	11 EL 20 W	11 IR 20 W	11 IL 20 W	0.8	0.9	11	1/4	20	●	○	○	○
11 ER 19 W	11 EL 19 W	11 IR 19 W	11 IL 19 W	0.8	1.0	11	1/4	19	●	○	○	○
11 ER 18 W	11 EL 18 W	11 IR 18 W	11 IL 18 W	0.8	1.0	11	1/4	18	●	○	○	○
11 ER 16 W	11 EL 16 W	11 IR 16 W	11 IL 16 W	0.9	1.1	11	1/4	16	●	○	○	○
11 ER 14 W	11 EL 14 W	11 IR 14 W	11 IL 14 W	0.9	1.1	11	1/4	14	●	○	○	○

⁽¹⁾ Special holder is required or standard holder can be amended by customer.

⁽¹⁾ Необходима специальная державка или самостоятельная доработка стандартной державки.

	PK3025	MS1515	N20K	HS2020
P Steel - Сталь	★			
M Stainless steel aust. - Аустенитная нерж. сталь	★	★		
K Cast iron - Чугун	★		☆	
N Aluminium - Алюминиевые сплавы	★	★	★	
S Hig. temp. alloy - Жаропрочные сплавы	★	★		★
H Hardened steel - Закаленные стали				★



p. 214



p. 215

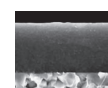

p. 177

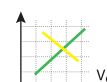

p. 211

Vertical

Вертикальная

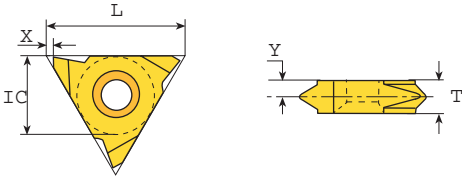

Designation/Обозначение		Dimensions/Размеры							TPI Ниток/дюйм	Grades / Сплавы				
External/Внешняя		Internal/Внутренняя		X	Y	T	L	I.C. дюйм		PK3025	MS1515	N20K	HS2020	
RH	LH		LH											
16V ER 19 W					1.0	0.9	3.6	16	3/8	19	●	○	○	○
16V ER 14 W					1.0	1.2	3.6	16	3/8	14	●	○	○	○
16V ER 11 W					1.0	1.5	3.6	16	3/8	11	●	○	○	○
P Steel - Сталь										★				
M Stainless steel aust. - Аустенитная нерж. сталь										★	★			
K Cast iron- Чугун										★		☆		
N Aluminium - Алюминиевые сплавы										★	★	★		
S Hig. temp. alloy - Жаропрочные сплавы										★	★		★	
H Hardened steel - Закаленные стали													★	



p. 214



p. 215

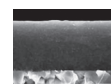

p.177



p. 211

Whitworth/Витворта - 55° BSW, BSF, BSP, BSB

Multitooth Многозубые пластины

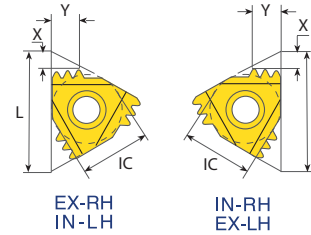

Designation/Обозначение				Dimensions/Размеры				TPI ниток/дюйм	No. of teeth/ Кол-во зубьев	Grades / Сплавы			
External/Внешняя		Internal/Внутренняя								PK3025	MS1515	N20K	HS2020
	Опорная пластина		Опорная пластина	X	Y	L	И.С. дюйм						
16 ER 14 W 2M	ES16M	16 IR 14 W 2M	IS16M	1.7	2.7	16	3/8	14	2	●	○	○	○
22 ER 14 W 3M	ES22M	22 IR 14 W 3M	IS22M	2.8	4.5	22	1/2	14	3	●	○	○	○
22 ER 11 W 2M	ES22M	22 IR 11 W 2M	IS22M	2.3	3.4	22	1/2	11	2	●	○	○	○
P Steel - Сталь										★			
M Stainless steel aust. - Аустенитная нерж. сталь										★	★		
K Cast iron - Чугун										★		☆	
N Aluminium - Алюминиевые сплавы										★	★	★	
S Hig. temp. alloy - Жаропрочные сплавы										★	★		★
H Hardened steel - Закаленные стали													★



p. 214



p.215

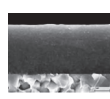

p.177

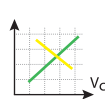

p. 211

NPT 60°

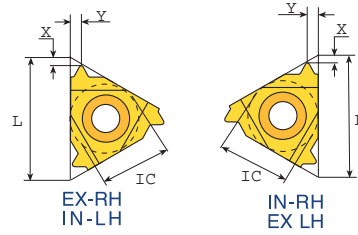
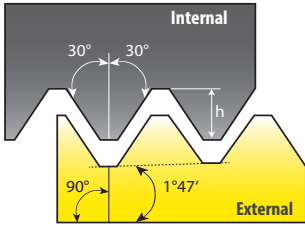

Designation/Обозначение				Dimensions/Размеры				TPI Ниток/дюйм	Grades / Сплавы			
External/Внешняя		Internal/Внутренняя		X	Y	L	I.C. дюйм		PK3025	MS1515	N20K	HS2020
RH	LH	RH	LH									
		06 IR 27 NPT	06 IL 27 NPT	0.6	0.6	6	5/32	27	●		○	
		08 IR 27 NPT	08 IL 27 NPT	0.6	0.7	8	3/16	27	●		○	
		08 IR 18 NPT	08 IL 18 NPT	0.6	0.6	8	3/16	18	●		○	
11 ER 27 NPT	11 EL 27 NPT	11 IR 27 NPT	11 IL 27 NPT	0.7	0.8	11	1/4	27	●	○	○	○
11 ER 18 NPT	11 EL 18 NPT	11 IR 18 NPT	11 IL 18 NPT	0.8	1.0	11	1/4	18	●	○	○	○
11 ER 14 NPT	11 EL 14 NPT	11 IR 14 NPT	11 IL 14 NPT	0.8	1.9	11	1/4	14	●	○	○	○
16 ER 27 NPT	16 EL 27 NPT	16 IR 27 NPT	16 IL 27 NPT	0.7	0.8	16	3/8	27	●	○	○	○
16 ER 18 NPT	16 EL 18 NPT	16 IR 18 NPT	16 IL 18 NPT	0.8	1.0	16	3/8	18	●	○	○	○
16 ER 14 NPT	16 EL 14 NPT	16 IR 14 NPT	16 IL 14 NPT	0.9	1.2	16	3/8	14	●	○	○	○
16 ER 11.5 NPT	16 EL 11.5 NPT	16 IR 11.5 NPT	16 IL 11.5 NPT	1.1	1.5	16	3/8	11.5	●	○	○	○
16 ER 8 NPT	16 EL 8 NPT	16 IR 8 NPT	16 IL 8 NPT	1.3	1.8	16	3/8	8	●	○	○	○
P Steel - Сталь								★				
M Stainless steel aust. - Аустенитная нерж. сталь								★	★			
K Cast iron - Чугун								★		☆		
N Aluminium - Алюминиевые сплавы								★	★	★		
S Hig. temp. alloy - Жаропрочные сплавы								★	★		★	
H Hardened steel - Закаленные стали											★	



p. 214



p. 215

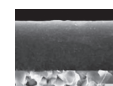

p. 177



p. 211

NPT 60° Multitooth Многозубые пластины

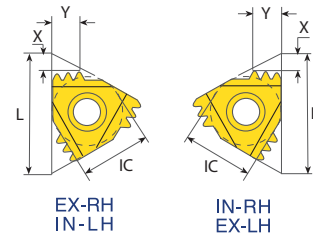
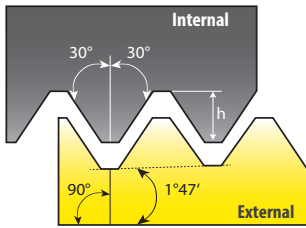

Designation/Обозначение				Dimensions/Размеры				ТPI нитек/ дюйм	No. of teeth/ Кол-во зубьев	Grades / Сплавы			
External/Внешняя		Internal/Внутренняя		X	Y	L	I.C. дюйм			PK3025	MS1515	N20K	HS2020
	Опорная пластина		Опорная пластина										
22 ER 11.5 NPT 2M	ES22M	22 IR 11.5 NPT 2M	IS22M	2.3	3.5	22	1/2	11.5	2	●	○	○	○
27 ER 11.5 NPT 3M	ES27M	27 IR 11.5 NPT 3M	IS27M	3.3	5.5	27	5/8	11.5	3	●		○	○
27 ER 8 NPT 2M	ES27M	27 IR 8 NPT 2M	IS27M	3.1	5.0	27	5/8	8	2	●		○	○

NPT Vertical Вертикальная

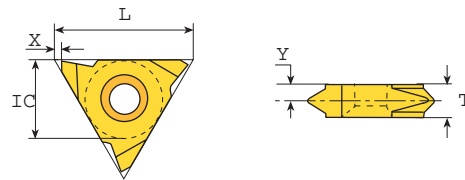

Designation/Обозначение				Dimensions/Размеры					ТPI нитек/ дюйм	Grades / Сплавы			
External/Внешняя		Internal/Внутренняя		X	Y	T	L	I.C. дюйм		PK3025	MS1515	N20K	HS2020
RH	LH	RH	LH										
16V ER 27 NPT			16V EL 27 NPT	1.0	0.8	3.6	16	3/8	27	●	○	○	○
16V ER 18 NPT			16V EL 18 NPT	1.0	1.0	3.6	16	3/8	18	●	○	○	○
16V ER 14 NPT			16V EL 14 NPT	1.0	1.2	3.6	16	3/8	14	●	○	○	○
16V ER 11.5 NPT			16V EL 11.5 NPT	1.0	1.5	3.6	16	3/8	11.5	●	○	○	○

P Steel - Сталь	★			
M Stainless steel aust. - Аустенитная нерж. сталь	★	★		
K Cast iron - Чугун	★		☆	
N Aluminium - Алюминиевые сплавы	★	★	★	
S Hig. temp. alloy - Жаропрочные сплавы	★	★		★
H Hardened steel - Закаленные стали				★



p. 214



p.215

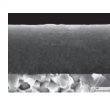

p.177

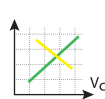

p. 211

NPTF-Dryseal

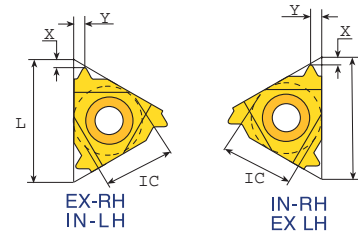
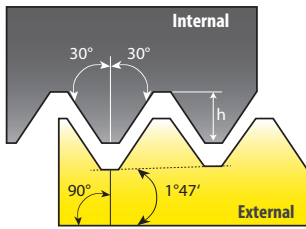

Designation/Обозначение				Dimensions/Размеры				ТPI ниток/ дюйм	Grades / Сплавы			
External/Внешняя		Internal/Внутренняя							PK3025	MS1515	N20K	HS2020
RH	LH	RH	LH	X	Y	L	И.С. дюйм					
		06 IR 27 NPTF	06 IL 27 NPTF	0.7	0.6	6	5/32	27	●		○	
		08 IR 27 NPTF	08 IL 27 NPTF	0.6	0.6	8	3/16	27	●		○	
		08 IR 18 NPTF	08 IL 18 NPTF	0.6	0.6	8	3/16	18	●		○	
11 ER 27 NPTF	11 EL 27 NPTF	11 IR 27 NPTF	11 IL 27 NPTF	0.7	0.7	11	1/4	27	●	○	○	○
11 ER 18 NPTF	11 EL 18 NPTF	11 IR 18 NPTF	11 IL 18 NPTF	0.8	1.0	11	1/4	18	●	○	○	○
11 ER 14 NPTF	11 EL 14 NPTF	11 IR 14 NPTF	11 IL 14 NPTF	0.8	1.0	11	1/4	14	●	○	○	○
16 ER 27 NPTF	16 EL 27 NPTF	16 IR 27 NPTF	16 IL 27 NPTF	0.7	0.7	16	3/8	27	●	○	○	○
16 ER 18 NPTF	16 EL 18 NPTF	16 IR 18 NPTF	16 IL 18 NPTF	0.8	1.0	16	3/8	18	●	○	○	○
16 ER 14 NPTF	16 EL 14 NPTF	16 IR 14 NPTF	16 IL 14 NPTF	0.9	1.2	16	3/8	14	●	○	○	○
16 ER 11.5 NPTF	16 EL 11.5 NPTF	16 IR 11.5 NPTF	16 IL 11.5 NPTF	1.1	1.5	16	3/8	11.5	●	○	○	○
16 ER 8 NPTF	16 EL 8 NPTF	16 IR 8 NPTF	16 IL 8 NPTF	1.3	1.8	16	3/8	8	●	○	○	○
P Steel - Сталь									★			
M Stainless steel aust. - Аустенитная нерж. сталь									★	★		
K Cast iron- Чугун									★		☆	
N Aluminium - Алюминиевые сплавы									★	★	★	
S Hig. temp. alloy - Жаропрочные сплавы									★	★		★
H Hardened steel - Закаленные стали												★



p. 214



p. 215

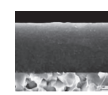

p.177

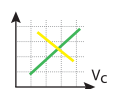

p. 211

BSPT

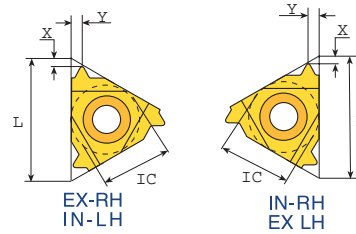
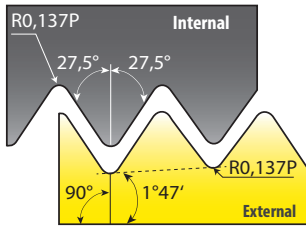

Designation/Обозначение				Dimensions/Размеры				ТPI ниток/дюйм	Grades / Сплавы			
External/Внешняя		Internal/Внутренняя							PK3025	MS1515	N20K	HS2020
RH	LH	RH	LH	X	Y	L	I.C. дюйм					
		06 IR 28 BSPT	06 IL 28 BSPT	0.7	0.6	6	5/32	28	●		○	
		08 IR 28 BSPT	08 IL 28 BSPT	0.6	0.6	8	3/16	28	●		○	
		08 IR 19 BSPT	08 IL 19 BSPT	0.6	0.6	8	3/16	19	●		○	
		11 IR 28 BSPT	11 IL 28 BSPT	0.6	0.6	11	1/4	28	●	○	○	○
		11 IR 19 BSPT	11 IL 19 BSPT	0.8	0.9	11	1/4	19	●	○	○	○
		11 IR 14 BSPT	11 IL 14 BSPT	0.9	1.0	11	1/4	14	●	○	○	○
16 ER 28 BSPT	16 EL 28 BSPT	16 IR 28 BSPT	16 IL 28 BSPT	0.6	0.6	16	3/8	28	●	○	○	○
16 ER 19 BSPT	16 EL 19 BSPT	16 IR 19 BSPT	16 IL 19 BSPT	0.8	0.9	16	3/8	19	●	○	○	○
16 ER 14 BSPT	16 EL 14 BSPT	16 IR 14 BSPT	16 IL 14 BSPT	1.0	1.2	16	3/8	14	●	○	○	○
16 ER 11 BSPT	16 EL 11 BSPT	16 IR 11 BSPT	16 IL 11 BSPT	1.1	1.5	16	3/8	11	●	○	○	○
P Steel - Сталь									★			
M Stainless steel aust. - Аустенитная нерж. сталь									★	★		
K Cast iron - Чугун									★		☆	
N Aluminium - Алюминиевые сплавы									★	★	★	
S Hig. temp. alloy - Жаропрочные сплавы									★	★		★
H Hardened steel - Закаленные стали												★

⁽¹⁾ Special holder is required or standard holder can be amended by customer.

⁽¹⁾ Необходима специальная державка или самостоятельная доработка стандартной державки.



p. 214



p.215

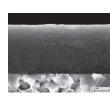

p.177

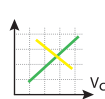

p. 211

BSPT

Vertical
Вертикальная

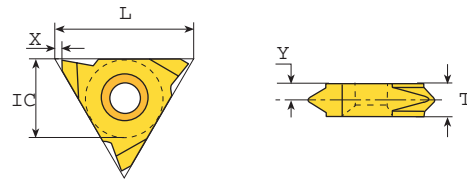

Designation/Обозначение										Grades / Сплавы							
External/Внешняя				Internal/Внутренняя				Dimensions/Размеры					ТPI ниток/ дюйм	PK3025	MS1515	N20K	HS2020
RH		LH		RH		LH		X	Y	T	L	И.С. дюйм					
16V	ER	28	BSPT					1.0	0.6	3.6	16	3/8	28	●	○		○
16V	ER	19	BSPT					1.0	0.9	3.6	16	3/8	19	●	○		○
16V	ER	14	BSPT					1.0	1.2	3.6	16	3/8	14	●	○		○
16V	ER	11	BSPT					1.0	1.5	3.6	16	3/8	11	●	○		○
P Steel - Сталь													★				
M Stainless steel aust. - Аустенитная нерж. сталь													★	★			
K Cast iron - Чугун													★		☆		
N Aluminium - Алюминиевые сплавы													★	★	★		
S Hig. temp. alloy - Жаропрочные сплавы													★	★		★	
H Hardened steel - Закаленные стали																★	



p. 214



p. 215

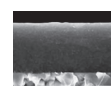

p. 177

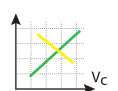

p. 211

Acme

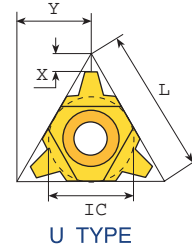
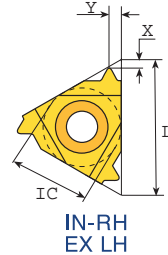
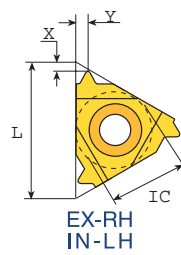
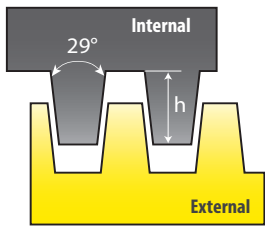

Designation/Обозначение				Dimensions/Размеры				TPI Ниток/дюйм	Grades / Сплавы			
External/Внешняя		Internal/Внутренняя							PK3025	MS1515	N20K	HS2020
RH	LH	RH	LH	X	Y	L	I.C. дюйм					
11 ER 16 ACME	11 EL 16 ACME	11 IR 16 ACME	11 IL 16 ACME	0.9	1.0	11	1/4	●	○	○	○	
16 ER 16 ACME	16 EL 16 ACME	16 IR 16 ACME	16 IL 16 ACME	0.9	1.0	16	3/8	●	○	○	○	
16 ER 14 ACME	16 EL 14 ACME	16 IR 14 ACME	16 IL 14 ACME	1.0	1.2	16	3/8	●	○	○	○	
16 ER 12 ACME	16 EL 12 ACME	16 IR 12 ACME	16 IL 12 ACME	1.1	1.2	16	3/8	●	○	○	○	
16 ER 10 ACME	16 EL 10 ACME	16 IR 10 ACME	16 IL 10 ACME	1.3	1.3	16	3/8	●	○	○	○	
16 ER 8 ACME	16 EL 8 ACME	16 IR 8 ACME	16 IL 8 ACME	1.5	1.5	16	3/8	●	○	○	○	
⁽¹⁾ 16 ER 6 ACME	⁽¹⁾ 16 EL 6 ACME	⁽¹⁾ 16 IR 6 ACME	⁽¹⁾ 16 IL 6 ACME	1.7	1.8	16	3/8	●	○	○	○	
22 ER 6 ACME	22 EL 6 ACME	22 IR 6 ACME	22 IL 6 ACME	1.8	2.1	22	1/2	●	○	○	○	
22 ER 5 ACME	22 EL 5 ACME	22 IR 5 ACME	22 IL 5 ACME	2.0	2.3	22	1/2	●	○	○	○	
22 ER 4 ACME	22 EL 4 ACME	22 IR 4 ACME	22 IL 4 ACME	2.1	2.2	22	1/2	●	○	○	○	
22U ER/L 4 ACME		22U IR/L 4 ACME		2.3	11.0	22U	1/2U	●	○	○	○	
27 ER 4 ACME	27 EL 4 ACME	27 IR 4 ACME	27 IL ACME	2.3	2.7	27	5/8	●		○	○	
27U ER/L 3 ACME		27U IR/L 3 ACME		2.8	13.7	27U	5/8U	●		○	○	
33U ER/L 2 ACME		33U IR/L 2 ACME		4.3	16.9	33U	3/4U	●		○		

** One cutting edge

⁽¹⁾ Special holder is required or standard holder can be amended by customer.

** Одна режущая кромка

⁽¹⁾ необходима специальная державка или самостоятельная доработка

P Steel - Сталь	★			
M Stainless steel aust. - Аустенитная нерж. сталь	★	★		
K Cast iron - Чугун	★		☆	
N Aluminium - Алюминиевые сплавы	★	★	★	
S Hig. temp. alloy - Жаропрочные сплавы	★	★		★
H Hardened steel - Закаленные стали				★



p. 214



p.215

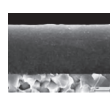

p.177

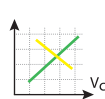

p. 211

Stub Acme

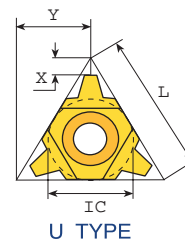
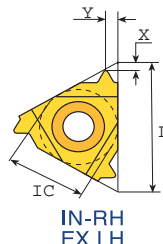
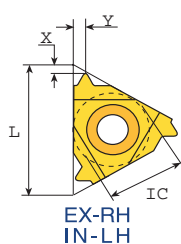
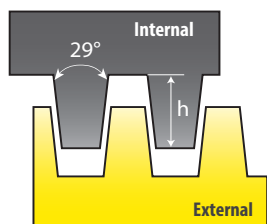

Designation/Обозначение				Dimensions/Размеры				TPI Ниток/дюйм	Grades / Сплавы			
External/Внешняя		Internal/Внутренняя		X	Y	L	I.C. дюйм		PK3025	MS1515	N20K	HS2020
RH	LH	RH	LH									
11 ER 16 STACME	11 EL 16 STACME			1.0	1.0	11	1/4	16	●	○	○	○
16 ER 16 STACME	16 EL 16 STACME	16 IR 16 STACME	16 IL 16 STACME	1.0	1.0	16	3/8	16	●	○	○	○
16 ER 14 STACME	16 EL 14 STACME	16 IR 14 STACME	16 IL 14 STACME	1.1	1.1	16	3/8	14	●	○	○	○
16 ER 12 STACME	16 EL 12 STACME	16 IR 12 STACME	16 IL 12 STACME	1.2	1.2	16	3/8	12	●	○	○	○
16 ER 10 STACME	16 EL 10 STACME	16 IR 10 STACME	16 IL 10 STACME	1.3	1.3	16	3/8	10	●	○	○	○
16 ER 8 STACME	16 EL 8 STACME	16 IR 8 STACME	16 IL 8 STACME	1.5	1.5	16	3/8	8	●	○	○	○
16 ER 6 STACME	16 EL 6 STACME	16 IR 6 STACME	16 IL 6 STACME	1.8	1.8	16	3/8	6	●	○	○	○
22 ER 5 STACME	22 EL 5 STACME	22 IR 5 STACME	22 IL 5 STACME	2.0	2.3	22	1/2	5	●	○	○	○
22 ER 4 STACME	22 EL 4 STACME	22 IR 4 STACME	22 IL 4 STACME	2.3	2.4	22	1/2	4	●	○	○	○
22U ER/L 4 STACME		22U IR/L 4 STACME		2.5	11.0	22U	1/2U	4	●	○	○	○
22U ER/L 3 STACME		22U IR/L 3 STACME		3.3	11.0	22U	1/2U	3	●	○	○	○
27 ER 4 STACME	27 EL 4 STACME	27 IR 4 STACME	27 IL 4 STACME	2.3	2.4	27	5/8	4	●		○	○
27 ER 3 STACME	27 EL 3 STACME	27 IR 3 STACME	27 IL 3 STACME	2.8	2.9	27	5/8	3	●		○	○
33U ER/L 2 STACME		33U IR/L 2 STACME		5.0	16.9	33U	3/4U	2	●		○	
P Steel - Сталь									★			
M Stainless steel aust. - Аустенитная нерж. сталь									★	★		
K Cast iron- Чугун									★		☆	
N Aluminium - Алюминиевые сплавы									★	★	★	
S Hig. temp. alloy - Жаропрочные сплавы									★	★		★
H Hardened steel - Закаленные стали												★

** One cutting edge

** Одна режущая кромка



p. 214



p. 215

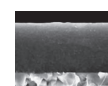

p. 177

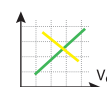

p. 211

Trapezoidal/ Трапецеидальная резьба-DIN103

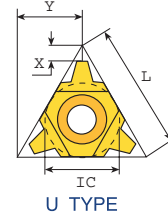
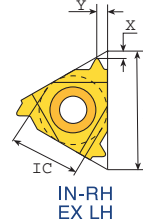
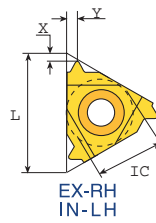
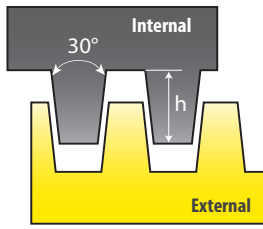

Designation/Обозначение										Grades / Сплавы						
External/Внешняя				Internal/Внутренняя				Dimensions/Размеры				ТPI ниток/ дюйм	PK3025	MS1515	N20K	HS2020
RH		LH		RH		LH		X	Y	L	I.C. дюйм					
16 ER 1.5 TR	16 EL 1.5 TR							1.0	1.1	16	3/8	1.5	●	○	○	○
16 ER 2 TR	16 EL 2 TR	16 IR 2 TR	16 IL 2 TR					1.0	1.3	16	3/8	2.0	●	○	○	○
16 ER 3 TR	16 EL 3 TR	16 IR 3 TR	16 IL 3 TR					1.3	1.5	16	3/8	3.0	●	○	○	○
16 ER 4 TR	16 EL 4 TR	16 IR 4 TR	16 IL 4 TR					1.3	1.5	16	3/8	4.0	●	○	○	○
22 ER 4 TR	22 EL 4 TR	22 IR 4 TR	22 IL 4 TR					1.8	1.9	22	1/2	4.0	●	○	○	○
22 ER 5 TR	22 EL 5 TR	22 IR 5 TR	22 IL 5 TR					2.0	2.4	22	1/2	5.0	●	○	○	○
22 ER 6 TR	22 EL 6 TR	22 IR 6 TR	22 IL 6 TR					2.0	2.4	22	1/2	6.0	●	○	○	○
22U ER/L 6													●	○	○	○
27 ER 6 TR	27 EL 6 TR	27 IR 6 TR	27 IL 6 TR					2.3	2.7	27	5/8	6.0	●	○	○	○
27 ER 7 TR	27 EL 7 TR	27 IR 7 TR	27 IL 7 TR					2.2	2.6	27	5/8	7.0	●		○	○
27U ER/L 8 TR				27U IR/L 8 TR				2.5	13.7	27U	5/8U	8.0	●		○	○
27U ER/L 9 TR				27U IR/L 9 TR				3.0	13.7	27U	5/8U	9.0	●		○	○
**27U ER/L 10 TR				**27U IR/L 10 TR				3.2	13.7	27U	5/8U	10.0	●		○	○
33U ER/L 12 TR				33U IR/L 12 TR				3.9	16.9	33U	3/4U	12.0	●		○	
P Steel - Сталь												★				
M Stainless steel aust. - Аустенитная нерж. сталь												★	★			
K Cast iron- Чугун												★		☆		
N Aluminium - Алюминиевые сплавы												★	★	★		
S Hig. temp. alloy - Жаропрочные сплавы												★	★		★	
H Hardened steel - Закаленные стали															★	

** One cutting edge

*** To be used only with holder SIR/L0014M16UB

(1) Special holder is required or standard holder can be amended by customer.

(2) Special holder is required or standard holder can be amended by customer or to used with holders: SIR/L0012L16B; SIR/L0014L16B.

(3) Only for Tr 40 x 7.0. To be used only with holder SIR/L0025S22UB.

** Одна режущая кромка

*** Используется только с державкой SIR/L0014M16UB

(1) Необходима специальная державка или самостоятельная доработка стандартной державки.

(2) Необходима специальная державка, самостоятельная доработка стандартной державки или державки: SIR/L0012L16B; SIR/L0014L16B

(3) только для резьбы Tr 40 x 7.0.



p.214



p.215

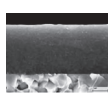

p.177

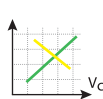

p.211

PG - DIN 40430

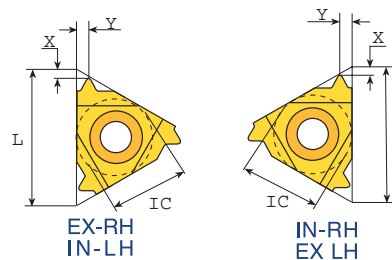
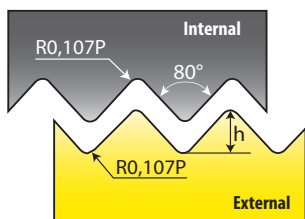

Designation/Обозначение				Dimensions/Размеры				TPI ниток/дюйм	Grades / Сплавы			
External/Внешняя		Internal/Внутренняя		X	Y	L	I.C. дюйм		PK3025	MS1515	N20K	HS2020
RH	СТАНДАРТ	RH	СТАНДАРТ									
		11 IR 18 PG	(PG 9)	0.8	0.9	11	1/4	18				
16 ER 20 PG	(PG 7)			0.7	0.8	16	3/8	20	●	○	○	○
16 ER 18 PG	(PG 9, 11, 13.5, 16)	16 IR 18 PG	(PG 11, 13.5, 16)	0.8	0.9	16	3/8	18	●	○	○	○
16 ER 16 PG	(PG 21, 29, 36, 42, 48)	16 IR 16 PG	(PG 21, 29, 36, 42, 48)	0.8	1.0	16	3/8	16	●	○	○	○

Thrust thread/ Упорная резьба- DIN 513

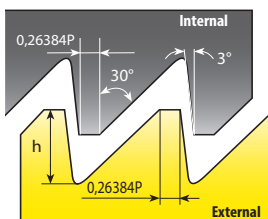

In standard version side plates are large the corner is the main cutting by edge. If you need other parameters specify this is ordering.

В стандартном исполнении пластин сторона с большим углом является главной режущей кромкой. Если вам необходимы другие параметры, уточните это в заказе.

External/Внешняя				Internal/Внутренняя				X	Y	L	I.C. дюйм	MM				
RH	LH	X	Y	RH	LH											
16 ER 2 SAGE	16 EL 2 SAGE	1.1	1.6	16 IR 2 SAGE	16 IL 2 SAGE	1.2	1.7	16	3/8	2.0	●	○	○	○		
22 ER 3 SAGE	22 EL 3 SAGE	1.5	2.4	22 IR 3 SAGE	22 IL 3 SAGE	1.9	2.9	22	1/2	3.0	●	○	○	○		
22 ER 4 SAGE	22 EL 4 SAGE	1.9	3.1	22 IR 4 SAGE	22 IL 4 SAGE	2.3	3.5	22	1/2	4.0	●	○	○	○		

* Special support plate required

* Необходима специальная опорная пластина AER 22U-1.5 SAGE 5/6, AEL 22U-1.5 SAGE 5/6, AIR 22U-1.5 SAGE 5/6, AIL 22U-1.5 SAGE 5/6.

	PK3025	MS1515	N20K	HS2020
P Steel - Сталь	★			
M Stainless steel aust. - Аустенитная нерж. сталь	★	★		
K Cast iron - Чугун	★		☆	
N Aluminium - Алюминиевые сплавы	★	★	★	
S Hig. temp. alloy - Жаропрочные сплавы	★	★		★
H Hardened steel - Закаленные стали				★



p. 214



p. 215

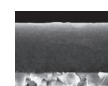

p. 177

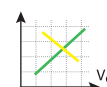

p. 211

Round/Круглая резьба - DIN 405

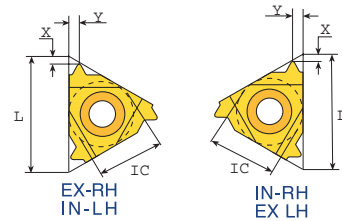
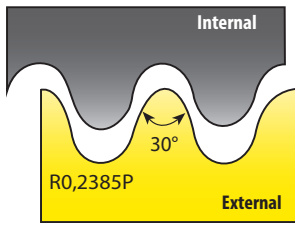

External/Внешняя		X	Y	Internal/Внутренняя		X	Y	L	I.C. дюйм	MM	Grades / Сплавы			
RH	LH			RH	LH						PK3025	MS1515	N20K	HS2020
16 ER 10 RD	16 EL 10 RD	1.1	1.2	16 IR 10 RD	16 IL 10 RD	1.1	1.2	16	3/8	10	●	○	○	○
16 ER 8 RD	16 EL 8 RD	1.4	1.3	16 IR 8 RD	16 IL 8 RD	1.4	1.4	16	3/8	8	●	○	○	○
16 ER 6 RD	16 EL 6 RD	1.5	1.7	16 IR 6 RD	16 IL 6 RD	1.4	1.5	16	3/8	6	●	○	○	○
22 ER 6 RD	22 EL 6 RD	1.5	1.7	22 IR 6 RD	22 IL 6 RD	1.5	1.7	22	1/2	6	●	○	○	○
22 ER 4 RD	22 EL 4 RD	2.2	2.3	22 IR 4 RD	22 IL 4 RD	2.2	2.3	22	1/2	4	●	○	○	○
27 ER 4 RD	27 EL 4 RD	2.2	2.3	27 IR 4 RD	27 IL 4 RD	2.2	2.3	27	5/8	4	●		○	○

Round/Круглая резьба - DIN 20400

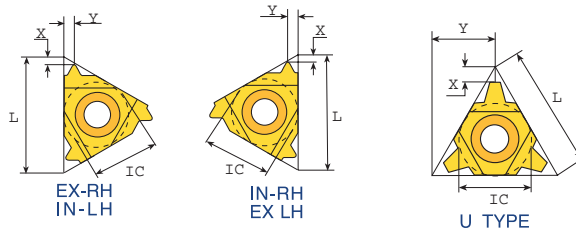
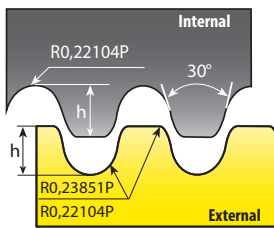

External/Внешняя		Internal/Внутренняя		X	Y	L	I.C. дюйм	MM	PK3025	MS1515	N20K	HS2020
RH	LH	RH	LH									
22 ER 4.0 RD 20400		22 IR 4.0 RD 20400		1.4	1.4	22	1/2	4.0	●	○	○	○
22 ER 5.0 RD 20400		22 IR 5.0 RD 20400		1.7	1.8	22	1/2	5.0	●	○	○	○
22 ER 6.0 RD 20400		22 IR 6.0 RD 20400		1.7	2.0	22	1/2	6.0	●	○	○	○

* Same insert for Internal and External Right Hand Thread
 * Одна и та же пластина для ВНУТРЕННЕЙ и ВНЕШНЕЙ Правой резьбы

	PK3025	MS1515	N20K	HS2020
P Steel - Сталь	★			
M Stainless steel aust. - Аустенитная нерж. сталь	★	★		
K Cast iron - Чугун	★		☆	
N Aluminium - Алюминиевые сплавы	★	★	★	
S Hig. temp. alloy - Жаропрочные сплавы	★	★		★
H Hardened steel - Закаленные стали				★



p. 214



p. 215

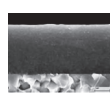

p. 177

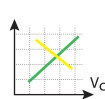

p. 211

UNJ UNJC, UNJF, UNJEF, UNJS

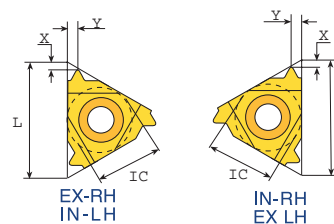
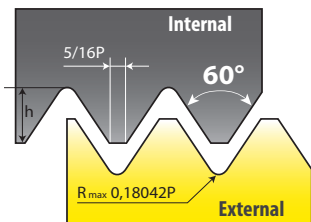

Designation/Обозначение				Dimensions/Размеры				TPI ниток/дюйм	Grades / Сплавы			
External/Внешняя		Internal/Внутренняя							PK3025	MS1515	N20K	HS2020
RH	LH	RH	LH	X	Y	L	И.С. дюйм					
11 ER 32 UNJ	11 EL 32 UNJ	11 IR 32 UNJ	11 IL 32 UNJ	0.6	0.6	11	1/4	32	●	○	○	○
11 ER 28 UNJ	11 EL 28 UNJ	11 IR 28 UNJ	11 IL 28 UNJ	0.6	0.6	11	1/4	28	●	○	○	○
11 ER 24 UNJ	11 EL 24 UNJ	11 IR 24 UNJ	11 IL 24 UNJ	0.7	0.8	11	1/4	24	●	○	○	○
11 ER 20 UNJ	11 EL 20 UNJ	11 IR 20 UNJ	11 IL 20 UNJ	0.8	0.9	11	1/4	20	●	○	○	○
11 ER 18 UNJ	11 EL 18 UNJ	11 IR 18 UNJ	11 IL 18 UNJ	0.8	1.0	11	1/4	18	●	○	○	○
11 ER 16 UNJ	11 EL 16 UNJ	11 IR 16 UNJ	11 IL 16 UNJ	0.8	1.0	11	1/4	16	●	○	○	○
11 ER 14 UNJ	11 EL 14 UNJ	11 IR 14 UNJ	11 IL 14 UNJ	0.9	1.0	11	1/4	14	●	○	○	○
16 ER 32 UNJ	16 EL 32 UNJ	16 IR 32 UNJ	16 IL 32 UNJ	0.6	0.6	16	3/8	32	●	○	○	○
16 ER 28 UNJ	16 EL 28 UNJ	16 IR 28 UNJ	16 IL 28 UNJ	0.6	0.6	16	3/8	28	●	○	○	○
16 ER 24 UNJ	16 EL 24 UNJ	16 IR 24 UNJ	16 IL 24 UNJ	0.7	0.8	16	3/8	24	●	○	○	○
16 ER 20 UNJ	16 EL 20 UNJ	16 IR 20 UNJ	16 IL 20 UNJ	0.8	0.9	16	3/8	20	●	○	○	○
16 ER 18 UNJ	16 EL 18 UNJ	16 IR 18 UNJ	16 IL 18 UNJ	0.8	1.0	16	3/8	18	●	○	○	○
16 ER 16 UNJ	16 EL 16 UNJ	16 IR 16 UNJ	16 IL 16 UNJ	0.8	1.0	16	3/8	16	●	○	○	○
16 ER 14 UNJ	16 EL 14 UNJ	16 IR 14 UNJ	16 IL 14 UNJ	1.0	1.2	16	3/8	14	●	○	○	○
16 ER 13 UNJ	16 EL 13 UNJ			1.0	1.3	16	3/8	13	●	○	○	○
16 ER 12 UNJ	16 EL 12 UNJ	16 IR 12 UNJ	16 IL 12 UNJ	1.1	1.4	16	3/8	12	●	○	○	○
16 ER 11 UNJ	16 EL 11 UNJ	16 IR 11 UNJ	16 IL 11 UNJ	1.1	1.5	16	3/8	11	●	○	○	○
16 ER 10 UNJ	16 EL 10 UNJ	16 IR 10 UNJ	16 IL 10 UNJ	1.1	1.5	16	3/8	10	●	○	○	○
16 ER 9 UNJ	16 EL 9 UNJ	16 IR 9 UNJ	16 IL 9 UNJ	1.2	1.6	16	3/8	9	●	○	○	○
16 ER 8 UNJ	16 EL 8 UNJ	16 IR 8 UNJ	16 IL 8 UNJ	1.2	1.6	16	3/8	8	●	○	○	○
									PK3025	MS1515	N20K	HS2020
P Steel - Сталь									★			
M Stainless steel aust. - Аустенитная нерж. сталь									★	★		
K Cast iron - Чугун									★		☆	
N Aluminium - Алюминиевые сплавы									★	★	★	
S Hig. temp. alloy - Жаропрочные сплавы									★	★		★
H Hardened steel - Закаленные стали												★



p. 214



p. 215

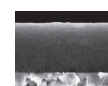

p. 177

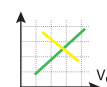

p. 211

MJ - ISO 5855

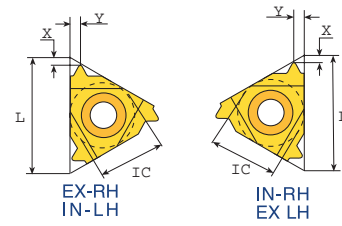
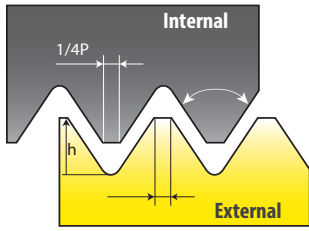

External/Внешняя		Internal/Внутренняя		X	Y	L	I.C. дюйм	мм	Grades / Сплавы					
RH	LH	RH	LH						PK3025	MS1515	N20K	HS2020		
		11	IR 1.0	MJ	0.7	0.8	11	1/4	1.0	●	○	○	○	
		11	IR 1.25	MJ	0.8	0.9	11	1/4	1.25	●	○	○	○	
		11	IR 1.5	MJ	0.8	1.0	11	1/4	1.5	●	○	○	○	
		11	IR 2.0	MJ	0.9	1.0	11	1/4	2.0	●	○	○	○	
16	ER 1.0	MJ	16	IR 1.0	MJ	0.7	0.8	16	3/8	1.0	●	○	○	○
16	ER 1.25	MJ	16	IR 1.25	MJ	0.8	0.9	16	3/8	1.25	●	○	○	○
16	ER 1.5	MJ	16	IR 1.5	MJ	0.8	1.0	16	3/8	1.5	●	○	○	○
16	ER 2.0	MJ	16	IR 2.0	MJ	1.0	1.3	16	3/8	2.0	●	○	○	○
										PK3025	MS1515	N20K	HS2020	
P Steel - Сталь										★				
M Stainless steel aust. - Аустенитная нерж. сталь										★	★			
K Cast iron - Чугун										★		☆		
N Aluminium - Алюминиевые сплавы										★	★	★		
S Hig. temp. alloy - Жаропрочные сплавы										★	★		★	
H Hardened steel - Закаленные стали													★	



p. 214



p.215

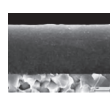

p.177

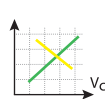

p. 211

Американская Buttress

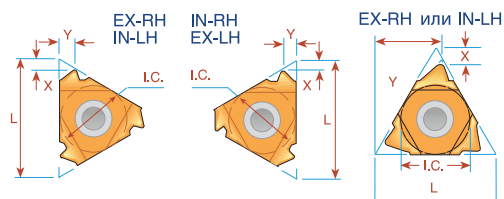
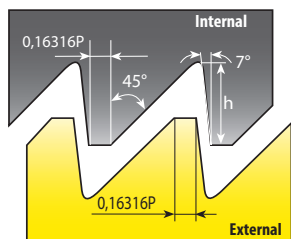

IMPORTANT NOTE:

In standard execution, the flank with the large angle is the leading edge. If otherwise required, please specify in your order.

ВНИМАНИЕ!

В стандартном исполнении пластин сторона с большим углом является главной режущей кромкой. Если вам необходимы другие параметры, уточните это в заказе.

External/Внешняя		Internal/Внутренняя		X	Y	L	I.C. дюйм	ТПИ ниток/ дюйм	Grades / Сплавы			
RH	LH	RH	LH						PK3025	MS1515	N20K	HS2020
11 ER 20 ABUT	11 EL 20 ABUT	11 IR 20 ABUT	11 IL 20 ABUT	1.0	1.3	11	1/4	20	●	○	○	○
11 ER 16 ABUT	11 EL 16 ABUT	11 IR 16 ABUT	11 IL 16 ABUT	1.0	1.5	11	1/4	16	●	○	○	○
16 ER 20 ABUT	16 EL 20 ABUT	16 IR 20 ABUT	16 IL 20 ABUT	1.0	1.3	16	3/8	20	●	○	○	○
16 ER 16 ABUT	16 EL 16 ABUT	16 IR 16 ABUT	16 IL 16 ABUT	1.0	1.5	16	3/8	16	●	○	○	○
16 ER 12 ABUT	16 EL 12 ABUT	16 IR 12 ABUT	16 IL 12 ABUT	1.4	2.0	16	3/8	12	●	○	○	○
16 ER 10 ABUT	16 EL 10 ABUT	16 IR 10 ABUT	16 IL 10 ABUT	1.5	2.3	16	3/8	10	●	○	○	○
22 ER 8 ABUT	22 EL 8 ABUT	22 IR 8 ABUT	22 IL 8 ABUT	2.1	3.3	22	1/2	8	●	○	○	○
22 ER 6 ABUT	22 EL 6 ABUT	22 IR 6 ABUT	22 IL 6 ABUT	2.1	3.4	22	1/2	6	●	○	○	○

Для выполнения большинства работ требуется опорная пластина

	PK3025	MS1515	N20K	HS2020
P Steel - Сталь	★			
M Stainless steel aust. - Аустенитная нерж. сталь	★	★		
K Cast iron - Чугун	★		☆	
N Aluminium - Алюминиевые сплавы	★	★	★	
S Hig. temp. alloy - Жаропрочные сплавы	★	★		★
H Hardened steel - Закаленные стали				★



p. 214



p. 215

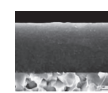

p. 177

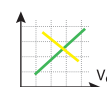

p. 211

OIL Threads/Резьба по нефтяному стандарту API Round

Спец 5В: 2008 (замковая)

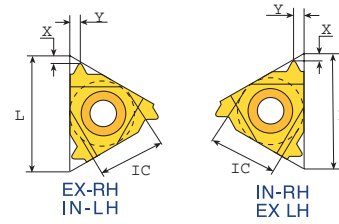
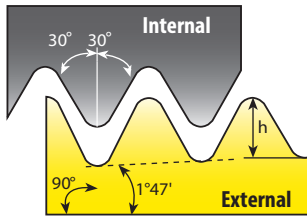

External/Внешняя				Internal/Внутренняя				X	Y	L	I.C. дюйм	TPI нитек/дюйм	Grades / Сплавы					
RH		LH		RH		LH							PK3025	MS1515	N20K	HS2020		
16	ER	10	API RD		16	IR	10	API RD		1.5	1.4	16	3/8	10	●	○	○	○
16	ER	8	API RD		16	IR	8	API RD		1.3	1.6	16	3/8	8	●	○	○	○

Multitooth Многозубые пластины

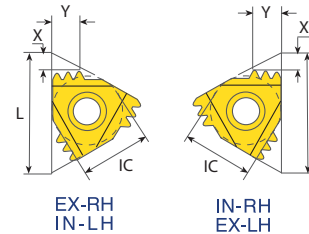

Designation/Обозначение				X	Y	L	I.C. дюйм	TPI нитек/ дюйм	No. of teeth/ Кол-во зубьев	PK3025	MS1515	N20K	HS2020
External/Внешняя		Internal/Внутренняя											
	Опорная пластина		Опорная пластина										
22 ER 10API RD 2M	ES22M	22 IR 10API RD 2M	IS22M	2.4	3.7	22	1/2	10	2	●	○	○	○
27 ER 10API RD 3M	ES27M	27 IR 10API RD 3M	IS27M	3.8	6.2	27	5/8	10	3	●		○	○
27 ER 8API RD 2M	ES27M	27 IR 8API RD 2M	IS27M	3.0	4.5	27	5/8	8	2	●		○	○

P Steel - Сталь	★			
M Stainless steel aust. - Аустенитная нерж. сталь	★	★		
K Cast iron - Чугун	★		☆	
N Aluminium - Алюминиевые сплавы	★	★	★	
S Hig. temp. alloy - Жаропрочные сплавы	★	★		★
H Hardened steel - Закаленные стали				★



p. 214



p.215

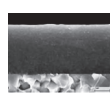

p.177

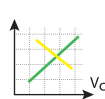

p. 211

OIL Threads/ Резьба по нефтяному стандарту API Round

Спец 7: 2001 (замковая)

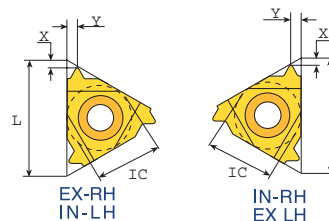
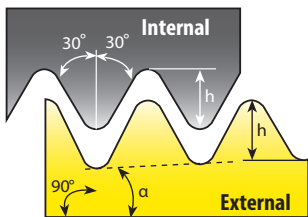

V-0.040

External/Внешняя		Internal/Внутренняя		X	Y	L	I.C. дюйм	Тарел/IPF Конусность дюйм/фут	ТПИ нитек/ дюйм	Connection No. or Size Номер соединения или размер	Grades / Сплавы			
RH	LH	RH	LH								PK3025	MS1515	N20K	HS2020
22 ER 5 API 403		22 IR 5 API 403		1.8	2.5	22	1/2	3	5	23/8-41/2REG	●	○	○	○

V-0.038R

External/Внешняя		Internal/Внутренняя		X	Y	L	I.C. дюйм	Тарел/IPF Конусность дюйм/фут	ТПИ нитек/ дюйм	Connection No. or Size Номер соединения или размер	PK3025	MS1515	N20K	HS2020
RH	LH	RH	LH											
27 ER 4 API 382		27 IR 4 API 382		2.1	2.8	27	5/8	2	4	NC23-NC50	●	○	○	○
27 ER 4 API 383		27 IR 4 API 383		2.1	2.8	27	5/8	3	4	NC56-NC77	●	○	○	○

P Steel - Сталь	★			
M Stainless steel aust. - Аустенитная нерж. сталь	★	★		
K Cast iron - Чугун	★		☆	
N Aluminium - Алюминиевые сплавы	★	★	★	
S Hig. temp. alloy - Жаропрочные сплавы	★	★		★
H Hardened steel - Закаленные стали				★



p. 214



p. 215

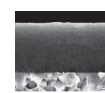

p. 177

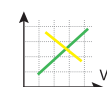

p. 211

OIL Threads/ Резьба по нефтяному стандарту API Round

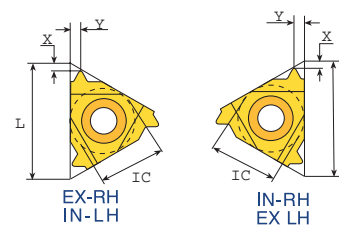
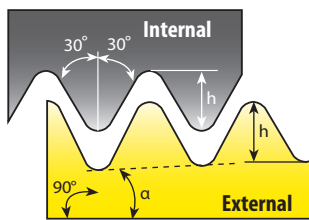

V-0.050

External/Внешняя		Internal/Внутренняя		X	Y	L	I.C. дюйм	Taper/IPF Конусность дюйм/фут	TPI НИТОК/ дюйм	Connection No. or Size Номер соединения или размер	Grades / Сплавы			
RH	LH	RH	LH								PK3025	MS1515	N20K	HS2020
27 ER 4 API 502		27 IR 4 API 502		2.0	3.0	27	5/8	2	4	65/8 REG	●	○	○	○
27 ER 4 API 503		27 IR 4 API 503		2.0	3.0	27	5/8	2	4	51/2, 75/8, 85/8 REG	●	○	○	○
											PK3025	MS1515	N20K	HS2020
P Steel - Сталь											★			
M Stainless steel aust. - Аустенитная нерж. сталь											★	★		
K Cast iron - Чугун											★		☆	
N Aluminium - Алюминиевые сплавы											★	★	★	
S Hig. temp. alloy - Жаропрочные сплавы											★	★		★
H Hardened steel - Закаленные стали														★



p. 214



p.215

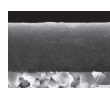

p.177

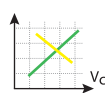

p. 211

Extreme - Line Casing/ Трапецеидальная резьба для обсадных труб

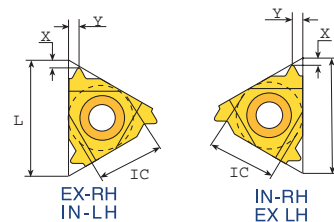
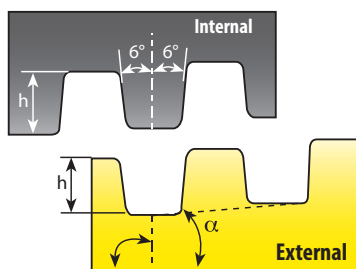

External/Внешняя		Internal/Внутренняя		X	Y	L	I.C. дюйм	Taper/IPF Конусность дюйм/фут	ТПИ НИТОК/ дюйм	Connection No. or Size Номер соединения или размер	Grades / Сплавы			
RH		RH									PK3025	MST1515	N20K	HS2020
22	ER 6 EL 1.5	22	IR 6 EL 1.5	1.9	1.9	22	1/2	1.50	6	5-7 5/8	●	○		○
22	ER 6 EL 1.25	22	IR 6 EL 1.25	2.4	2.3	22	1/2	1.25	5	8 5/8 - 10 3/4	●	○		○

Buttress Casing/ Buttress для обсадных труб

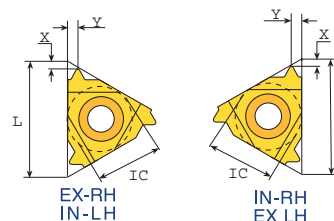
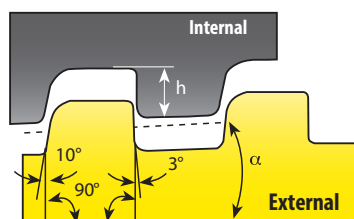

External/Внешняя		Internal/Внутренняя		X	Y	L	I.C. дюйм	Taper/IPF Конусность дюйм/фут	ТПИ НИТОК/ дюйм	Connection No. or Size Номер соединения или размер	PK3025	MST1515	N20K	HS2020
RH		RH												
22	ER 5 BUT 0.75	22	IR 5 BUT 0.75	2.2	2.4	22	1/2	0.75	5	4 1/2 - 13 3/8	●	○		○
22	ER 5 BUT 1.0	22	IR 5 BUT 1.0	2.3	2.4	22	1/2	1.00	5	16-20	●	○		○

P Steel - Сталь	★			
M Stainless steel aust. - Аустенитная нерж. сталь	★	★		
K Cast iron - Чугун	★		☆	
N Aluminium - Алюминиевые сплавы	★	★	★	
S Hig. temp. alloy - Жаропрочные сплавы	★	★		★
H Hardened steel - Закаленные стали				★



p. 214



p. 215

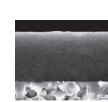

p. 177

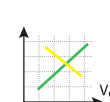

p. 211

A series of horizontal dotted lines for writing, spanning the width of the page.

Recommended cutting speed (m/min) for thread turning inserts

Рекомендации по скорости резания (м/мин) для токарных резьбовых пластин

Стандарт ISO	Material Обрабатываемый материал		Specifications Характеристики	Grades /Сплавы							
				HS2020	MS1515	PK3025	N20K				
P	Non-Alloy Steel and Cast Steel, Free Cutting Steel Нелегированная и литейная сталь, автоматная сталь	<0.25%C	Annealed Отожженная		110-210	120-180					
		™0.25%C	Annealed Отожженная								
		<0.55%C	Quenched & Tempered Закаленная и отпущенная								
		™0.55%C	Annealed Отожженная								
			Quenched & Tempered Закаленная и отпущенная								
	Низколегированная и литейная сталь (менее 5% легирующих добавок)		Annealed Отожженная		90-140	80-130					
High Alloy Steel Низколегированная и литейная сталь (менее 5% легирующих добавок)		Annealed Отожженная		70-90	60-80						
		Quenched & Tempered Закаленная и отпущенная									
M	Stainless Steel Нержавеющая и литейная сталь		Pearlitic/Martensitic Ферритно-мартенситная		110-160	90-130	50-80				
			Martensitic Мартенситная								
			Austenitic Аустенитная								
K	Cast Iron Nodular (GGG) Высокопрочный чугун GGG		Ferritic/ Pearlitic Ферритно-перлитный		120-150	100-130					
	Grey Cast Iron (GGG) Серый чугун GG		Pearlitic / Перлитный								
			Ferritic / Ферритный								
	Malleable Cast Iron Ковкий чугун		Pearlitic / Перлитный					140-150	120-130		
N	Aluminium-Wrought Alloy Алюминиевые сплавы, поковки		Not Cureable Без отверждения		700-1000		600-800				
	Aluminium-Cast Alloyed Алюминиевые сплавы, отливки		Cured/С отверждения								
			Not Cureable Без отверждения								
			Cured/С отверждения								
	Copper Alloys Медные сплавы		<=12% Si					High Temperature Жаропрочные	280-750		200-550
			>12% Si								
	Non Metallic Неметаллы		>1% Pb					Free Cutting Легкообрабатываемые	190-350		150-250
			Brass / Латунь								
			Electrolytic Copper Электролитическая медь								
			Duroplastics, Fiber Plastics Термореак. пластмасса, волокниты			100-200					
S	High Temp.Alloys, Super Alloys Жаропрочные сплавы, суперсплавы		Fe based на основе железа	Annealed/Отожженные	20-80	30-65	25-60				
				Cured /Отожженные							
			Nior Co based на основе никеля и кобальта	Annealed/Отожженные							
				Cured /Отожженные							
				Cast /Литые							
Titanium Alloys Титановые сплавы			Alpha + Beta Alloys Cured Отвержденные сплавы Alpha и Beta	30-60	40-50	35-45	35-45				
H	Hardened Steel Закаленная сталь		Hardened 45-50 HRC Закаленная 45-50 HRC	30-60	40-50	35-45					
			Hardened 51-55 HRC Закаленная 51-55 HRC								
			Hardened 56-62 HRC Закаленная 56-62 HRC								
Chilled Cast Iron Отбеленный чугун			Cast /Литой	20-50	30-40	25-35					
Cast Iron Чугун			Hardened /Закаленный	20-40	20-30	15-25					

Anvils / Опорные пластины

Thread Helix Angle

Угол подъема резьбы

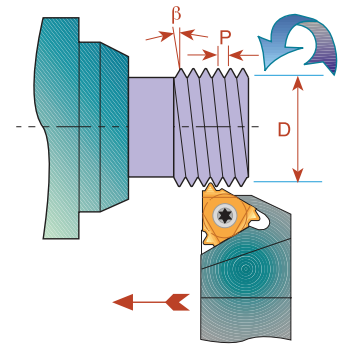
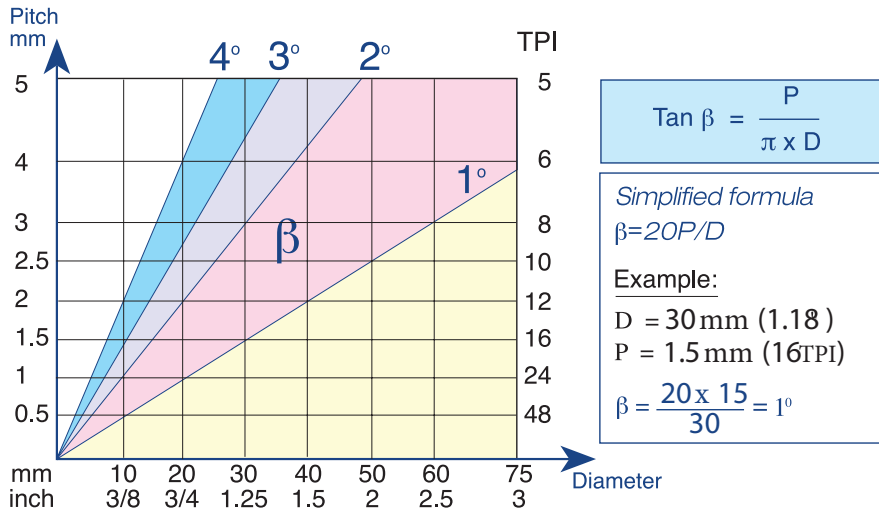

Standard and Slanted Anvils

Опорные пластины стандартные и с углом наклона

Toolholder Pockets have a built in 1.5° helix angle. This angle may be adjusted to better match the thread helix angle by simply changing the anvil.
Negative helix is usually used when threading RH thread with LH Holder or LH thread with RH Holder.

У державок опорная плоскость под пластину располагается под углом 1,5°. Для получения нужного угла подъема резьбы этот угол может быть изменен простой заменой опорной пластины.

Отрицательный угол подъема необходим при обработке Правой (RH) резьбыевой (LH) державкой, либо Левой (LH) резьбыевой (RH) державкой.

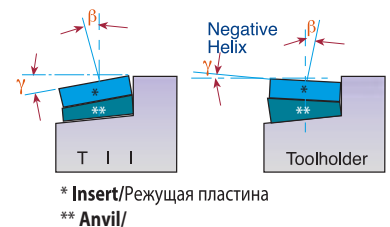

Number of passes and depth of cut per pass for multitooth insert

Число проходов и глубина резьбы для многозубых пластин

	Pitch mm Шаг мм	Insert Size Размер пластины		No. of Teeth Кол-во зубьев	Ordering Code Обозначение	No. of Passes Число проходов	Depth of Cut per pass Глубина одного прохода			
		L	I.C. (in) (дюйм)				1	2	3	4
ISO External Внешняя	1.00	16	3/8	3	16 ER 1.0 ISO 3M	2	0.38	0.25		
	1.50	16	3/8	2	16 ER 1.5 ISO 2M	3	0.42	0.30	0.20	
	1.50	22	1/2	3	22 ER 1.5 ISO 3M	2	0.55	0.37		
	2.00	22	1/2	2	22 ER 2.0 ISO 2M	3	0.57	0.40	0.28	
	2.00	22	1/2	3	22 ER 2.0 ISO 3M	2	0.76	0.4		
	3.00	27	5/8	2	27 ER 3.0 ISO 2M	4	0.59	0.51	0.42	0.32
ISO Internal Внутренняя	1.00	16	3/8	3	16 IR 1.0 ISO 3M	2	0.33	0.25		
	1.50	16	3/8	2	16 IR 1.5 ISO 2M	3	0.38	0.2	0.20	
	1.50	22	1/2	3	22 IR 1.5 ISO 3M	2	0.50	0.37		
	2.00	22	1/2	2	22 IR 2.0 ISO 2M	3	0.52	0.37	0.26	
	2.00	22	1/2	3	22 IR 2.0 ISO 3M	2	0.70	0.45		
	3.00	27	5/8	2	27 IR 3.0 ISO 2M	4	0.58	0.46	0.39	0.30
UN External Внешняя	16	16	3/8	2	16 ER 16 UN 2M	3	0.44	0.31	0.22	
	16	22	1/2	3	22 ER 16 UN 3M	2	0.58	0.39		
	12	22	1/2	2	22 ER 16 UN 3M	3	0.59	0.42	0.30	
	12	22	1/2	3	22 ER 12 UN 2M	2	0.78	0.52		
	8	27	5/8	2	22 ER 12 UN 3M	4	0.62	0.54	0.45	0.354
UN Internal Внутренняя	16	16	3/8	2	16 IR 16 UN 2M	3	0.42	0.28	0.22	
	16	22	1/2	3	22 IR 16 UN 3M	2	0.55	0.37		
	12	22	1/2	2	22 IR 12 UN 2M	3	0.53	0.38	0.31	
	12	22	1/2	3	22 IR 12 UN 3M	2	0.74	0.48		
	8	27	5/8	2	27 IR 8 UN 2M	4	0.63	0.50	0.40	0.30
Whitworth 55° External Витворта 55° Внешняя	14	16	3/8	2	16 ER 14 W 2M	3	0.52	0.37	0.27	
	14	22	1/2	3	22 ER 14 W 3M	2	0.70	0.46		
	11	22	1/2	2	22 ER 11 W 2M	3	0.67	0.47	0.34	
Whitworth 55° Internal Витворта 55° Внутренняя	14	16	3/8	2	16 IR 14 W 2M	3	0.52	0.37	0.27	
	14	22	1/2	3	22 IR 14 W 3M	2	0.70	0.46		
	11	22	1/2	2	22 IR 11 W 2M	2	0.67	0.47	0.34	
NPT External Внешняя	14	16	3/8	2	16 ER 14 NPT 2M	3				
	11.5	22	1/2	2	22 ER 11.5 NPT 2M	4	0.54	0.47	0.37	0.30
	11.5	27	5/8	3	27 ER 11.5 NPT 3M	4	0.76	0.54	0.38	
	8	27	5/8	2	27 ER 8 NPT 2M	4	0.81	0.60	0.55	0.45
NPT Internal Внутренняя	14	16	3/8	2	16 IR 14 NPT 2M	3				
	11.5	22	1/2	2	22 IR 11.5 NPT 2M	4	0.54	0.47	0.37	0.30
	11.5	27	5/8	3	27 IR 11.5 NPT 3M	4	0.76	0.54	0.38	
	8	27	5/8	2	27 IR 8 NPT 2M	4	0.81	0.60	0.55	
API Round External Внешняя	10	22	1/2	2	22 ER 10 APIRD 2M	3	0.60	0.50	0.31	0.45
	10	27	5/8	3	327 ER 10 APIRD 3M	2	1.00	0.41		
	8	27	5/8	2	27 ER 8 APIRD 2M	3	0.80	0.60	0.41	
API Round Internal Внутренняя	10	22	1/2	2	22 IR 10 APIRD 2M	3	0.60	0.50	0.31	
	10	27	5/8	3	27 IR 10 APIRD 3M	2	1.00	0.41		
	8	27	5/8	2	27 IR 8 APIRD 2M	3	0.80	0.60	0.41	

Number of threading passes selection for single point inserts

Число проходов для однозубых пластин

Pitch: mm Шаг: TPI	0.5	0.8	1.0	1.25	1.5	1.75	2.0	2.5	3.0	4.0	6.0
Number of passes Кол-во проходов	3-6	4-7	4-9	6-10	5-11	9-12	6-13	7-15	8-17	10-20	11-22

NOTES:

1. For most standard applications the middle of the range is a good starting point.
2. For most materials, the tougher the material, the higher the number of cutting passes you should select.
3. As a general rule of thumb, fewer passes are better than more speed.

Примечание:

1. Как правило, наиболее подходящим является среднее значение числа проходов.
2. Как правило, чем прочнее материал, тем большее число проходов необходимо сделать.
3. Общее правило: лучше сделать меньшее число проходов, чем увеличить скорость.

Задний угол режущей пластины ω

$$\omega = \text{ArcTan} (\text{Tan } \alpha \times \text{Tan } \phi)$$

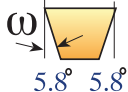

$\omega = 5.8^\circ$

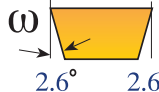

2.6°

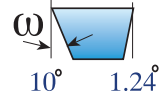

10°

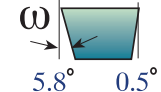

5.8°

$\phi = 10^\circ$ for External holders

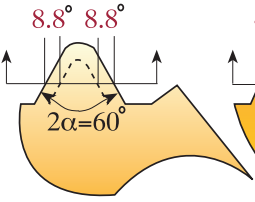

$\omega = 8.8^\circ$

ISO, UN
Partial profile 60°
NPT

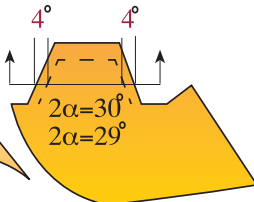

4°

Trapezoidal
ACME
STACME

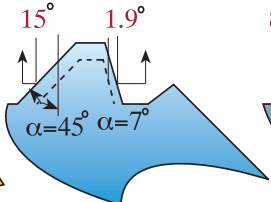

15°

American
Buttress

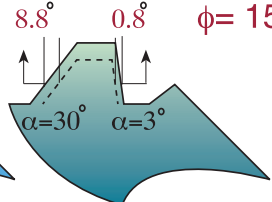

8.8°

Metric buttress thread
(DIN 513)

$\phi = 15^\circ$ for Internal holders

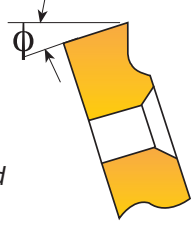

1. In most thread forms internal and external threads have different depth and radii, thus tools are not interchangeable. В большинстве резьб, у внутренней и внешней резьбы разные высота и радиус профиля, поэтому инструмент внеш. и внутр. не взаимозаменяемый.

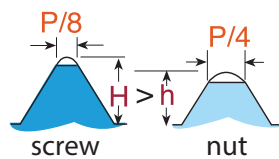

2. The insert relief angle of a standard external toolholder is 10°; for an internal toolholder it is 15°. This 5° difference is to provide additional necessary radial clearance.

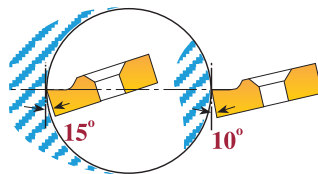

У стандартных внешних державок задний угол 10°, а у внутренних 15°. Эта разница в 5° нужна, чтобы обеспечить дополнительно необходимый радиальный зазор.

3. Our built-in relief angles ensure automatic insert flank angle clearance.

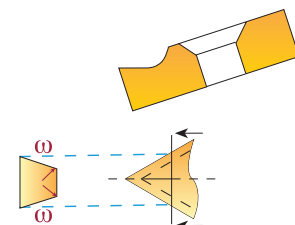

Угол наклона опорной плоскости под пластину задает необходимый задний угол режущей пластине.

4. Profiles of internal & external threading inserts are precision ground to ensure accurate thread geometry when used in their corresponding toolholders. Using internal inserts with an external holder will result in distortion of angle and insert geometry.

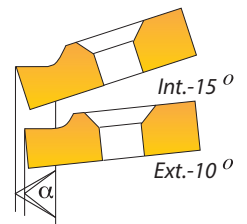

Профили внешней и внутренней пластины с высокоточной заточкой обеспечивают точность геометрии резьбы, когда пластины используются в соответствующих державках. Использование внутренней пластины во внешней державке приведет к искажению углов и геометрии пластины.

5. Insert and toolholder should always match. An IN-RH insert must be used with an IN-RH toolholder. No mismatch is allowed.

Пластина всегда должна соответствовать державке. В IN-RH (Внут.-Прав.) державке должна быть IN-RH (Внут.-Прав.) пластина. Несоответствие НЕ ДОПУСТИМО!

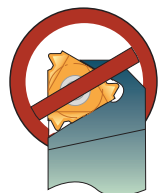

Рекомендации по замене опорных пластин

As can be seen from the chart, some Pitch to Diameter combinations require an anvil change. If change is required, use AE anvils for EX-RH and IN-LH toolholders and AI anvils for IN-RH and EX-LH toolholders.

Как показано на диаграмме, комбинация некоторых диаметров и шагов требует замены стандартной опорной пластины. При необходимости замены, используйте AE пластины для EX-RH (Внеш.-Прав.) и IN-LH (Внут.-Лев.) державок, и AI пластины для IN-RH (Внут.-Прав.) и EX-LH (Внеш.-Лев.) державок.

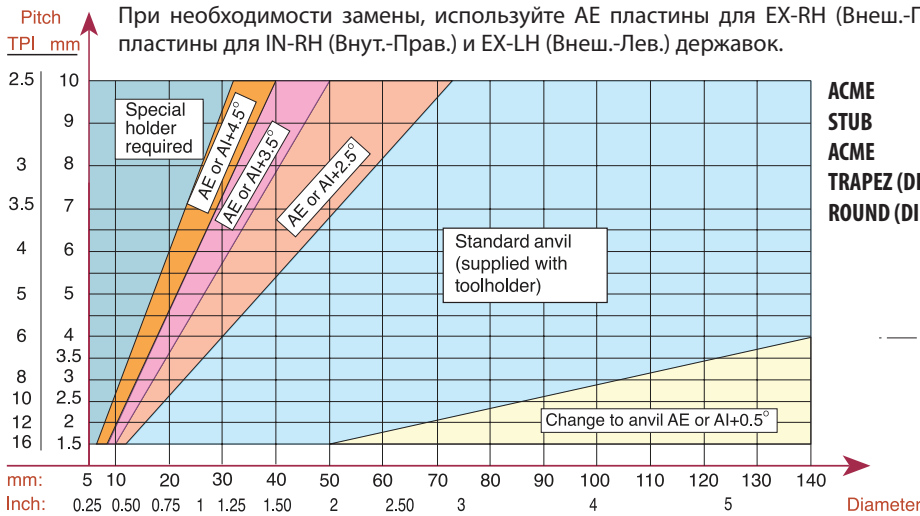

ACME
STUB
ACME
TRAPEZ (DIN 103)
ROUND (DIN 405)

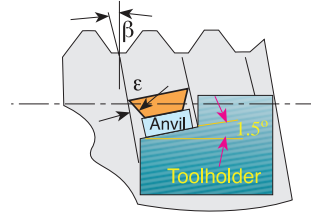

As can be seen from the chart, most applications do not require an anvil change. If change is required, use AE anvils for EX-RH and IN-LH toolholders and AI anvils for IN-RH and EX-LH toolholders.

Как показано на диаграмме, большинство случаев не требует замены опорной пластины. При необходимости замены, используйте AE пластины для EX-RH (Внеш.-Прав.) и IN-LH (Внут.-Лев.) державок, и AI пластины для IN-RH (Внут.-Прав.) и EX-LH (Внеш.-Лев.) державок.

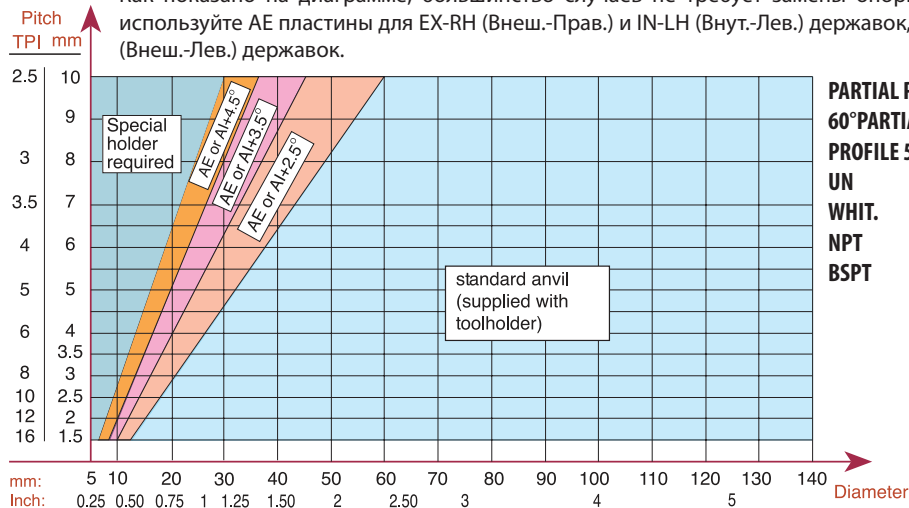

PARTIAL PROFILE
60° PARTIAL
PROFILE 55° ISO
UN
WHIT.
NPT
BSPT

As can be seen from the chart, most applications require an anvil change. In most cases a negative anvil is required. Use AE anvils for EX-RH and IN-LH toolholders and AI anvils for IN-RH and EX-LH toolholders.

Как показано на диаграмме, большинство случаев требует замены опорной пластины. Как правило, необходима отрицательная опорная пластина. Используйте AE пластины для EX-RH (Внеш.-Прав.) и IN-LH (Внут.-Лев.) державок, и AI пластины для IN-RH (Внут.-Прав.) и EX-LH (Внеш.-Лев.) державок.

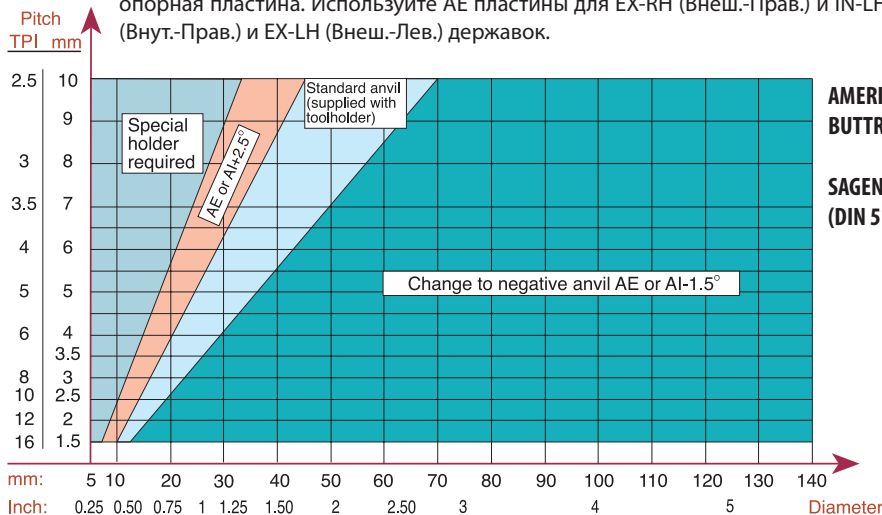

AMERICAN
BUTTRESS
SAGENGWINDE
(DIN 513)

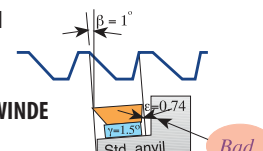

Before Anvil change



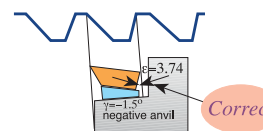

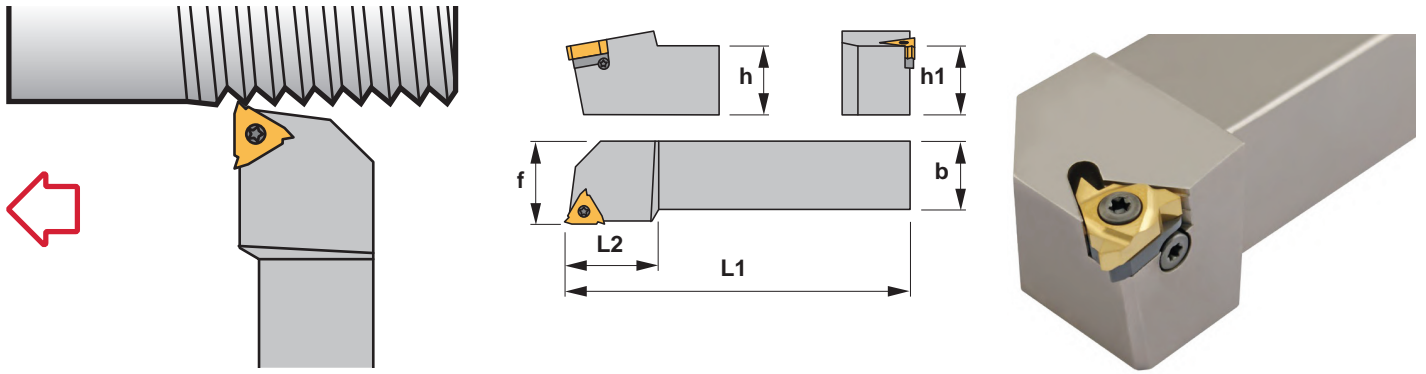

Replacing the standard anvil with an anvil with negative angle, will eliminate side rubbing



After Anvil change



STXN 90°

Reference	h=h1	b	L1	L2	f	Insert size						
STXN R/L 1212 F16	12	12	80	25	16	16 ER/L..	0,100	SA3T	5510	YE3	YI3	SY3
STXN R/L 1616 H16	16	16	100	25	20	16 ER/L..	0,200	SA3	5510	YE3	YI3	SY3
STXN R/L 2020 K16	20	20	125	28	25	16 ER/L..	0,400	SA3	5510	YE3	YI3	SY3
STXN R/L 2525 M16	25	25	150	28	32	16 ER/L..	0,700	SA3	5510	YE3	YI3	SY3
STXN R/L 3232 P16	32	32	170	28	40	16 ER/L..	1,050	SA3	5510	YE3	YI3	SY3
STXN R/L 2525 M22	25	25	150	34	32	22 ER/L..	0,700	SA4	5520	YE4	YI4	SY4
STXN R/L 3232 P22	32	32	170	34	40	22 ER/L..	1,300	SA4	5520	YE4	YI4	SY4
STXN R/L 4040 R22	40	40	200	34	50	22 ER/L..	3,000	SA4	5520	YE4	YI4	SY4
STXN R/L 2525 M27	25	25	150	34	32	27 ER/L..	0,700	SA5	5525	YE5	YI5	SY5
STXN R/L 3232 P27	32	32	170	34	40	27 ER/L..	1,300	SA5	5525	YE5	YI5	SY5
STXN R/L 4040 R27	40	40	200	34	50	27 ER/L..	3,000	SA5	5525	YE5	YI5	SY5
STXN R/L 5050 S27	50	50	250	34	60	27 ER/L..	5,800	SA5	5525	YE5	YI5	SY5

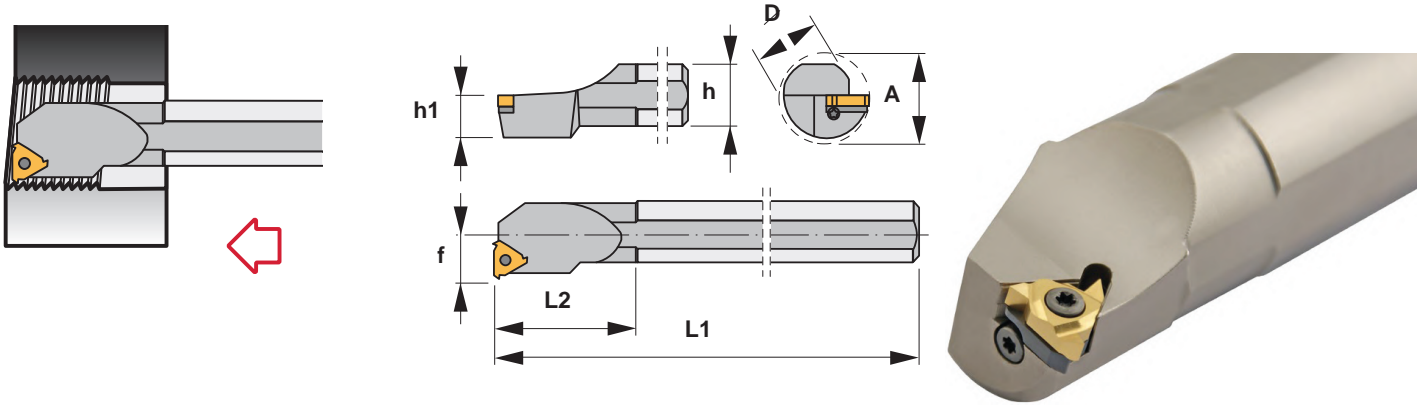

STXN 90°

Reference	D	h	h1	L1	L2	f	A	Insert size							Nm
S10K STXN R/L 11	10	9	4,5	125	16	7,3	13	11 NR/L..	0,070	1225	5507	-	-	-	0.9
S16M STXN R/L 11	16	15	7,5	150	25	8,9	16	11 NR/L..	0,200	1225	5507	-	-	-	0.9
S16M STXN R/L 16	16	15	7,5	150	30	11,5	20	16 NR/L..	0,200	SN3	5510	-	-	-	2.0
S20Q STXN R/L 16	20	18	9,0	180	35	13,4	24	16 NR/L..	0,400	SA3T	5510	YI3	YE3	SY3	2.0
S25R STXN R/L 16	25	23	11,5	200	40	16,3	29	16 NR/L..	0,700	SA3	5510	YI3	YE3	SY3	2.0
S32S STXN R/L 16	32	30	15,0	250	45	19,6	36	16 NR/L..	1,500	SA3	5510	YI3	YE3	SY3	2.0
S40T STXN R/L 16	40	37	18,5	300	50	23,8	44	16 NR/L..	2,850	SA3	5510	YI3	YE3	SY3	2.0
S20Q STXN R/L 22	20	18	9,0	180	35	15,6	27	22 NR/L..	0,400	SN4	5520	-	-	-	4.0
S25R STXN R/L 22	25	23	11,5	200	40	17,2	32	22 NR/L..	0,700	SA4	5520	YI4	YE4	SY4	4.0
S32S STXN R/L 22	32	30	15,0	250	45	21,5	39	22 NR/L..	1,500	SA4	5520	YI4	YE4	SY4	4.0
S40T STXN R/L 22	40	37	18,5	300	50	25,8	47	22 NR/L..	2,850	SA4	5520	YI4	YE4	SY4	4.0
S32S STXN R/L 27	32	30	15,0	250	45	22,4	40	27 NR/L..	1,500	SA5	5525	YI5	YE5	SY5	5.0
S40T STXN R/L 27	40	37	18,5	300	50	26,4	48	27 NR/L..	2,850	SA5	5525	YI5	YE5	SY5	5.0
S50U STXN R/L 27	50	47	23,5	350	60	31,4	58	27 NR/L..	5,200	SA5	5525	YI5	YE5	SY5	5.0
S60V STXN R/L 27	60	57	28,5	400	60	36,4	69	27 NR/L..	8,550	SA5	5525	YI5	YE5	SY5	5.0

Blank page with horizontal dotted lines for writing.



TOOLS WITH CARBIDE INSERTS
ИНСТРУМЕНТ СО СМЕННЫМИ ТВЕРДОСПЛАВНЫМИ ПЛАСТИНАМИ

MILLING WITH CARBIDE INSERTS
ФРЕЗЫ СО СМЕННЫМИ
ТВЕРДОСПЛАВНЫМИ ПЛАСТИНАМИ

TABLE OF CONTENTS / СОДЕРЖАНИЕ

SOLID CARBIDE TOOLS		3
ТВЕРДОСПЛАВНЫЙ ИНСТРУМЕНТ		
1	Carbide mills Твердосплавные фрезы	5
2	Carbide drills Твердосплавные сверла	39
3	Special tools Специальные инструменты	49
TOOLS WITH CARBIDE INSERTS		54
ИНСТРУМЕНТ СО СМЕННЫМИ ТВЕРДОСПЛАВНЫМИ ПЛАСТИНАМИ		
4	Turning carbide inserts Токарные твердосплавные пластины	55
5	Toolholders for external turning Токарные державки для наружной обработки	91
6	Toolholders for internal turning Токарные державки для внутренней обработки	123
7	Grooving and parting off Канавка и отрезка	143
8	Threading inserts Резьбонарезные пластины	175
9	Milling with carbide inserts Фрезы со сменными твердосплавными пластинами	217
<input type="checkbox"/>	Alloy application Область применения сплавов	219
<input type="checkbox"/>	Classification Классификация	222
<input type="checkbox"/>	Shoulder milling cutters Фрезы для обработки пазов и уступов	224
<input type="checkbox"/>	Shoulder milling cutters with APKT Инструмент для обработки пазов и уступов с пластинами APKT	232
<input type="checkbox"/>	Face milling Торцевые фрезы	248
<input type="checkbox"/>	Milling with round inserts Фрезы с круглыми пластинами	256
<input type="checkbox"/>	High feeds milling Фрезы для работы на высокой подаче	266
10	Drills with carbide inserts Сверла со сменными пластинами	271

Alloy description

Описание сплавов

P3530M

HC-P35 | HC-M30

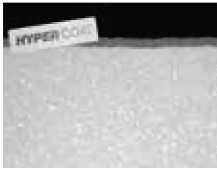

Specification: Composition: Co 9.0%; mixed carbides 4.0%; WC balance | Grain size: 1-1.5µm | Hardness: HV1510 | Coating specification: PVD (TiAl)N + TiN; 4 µm

Recommended application: First choice for dry machining of steels.

Состав: Co 9.0 %; соединения карбидов 4.0 %; WC ост. | размер зерна: 1-1.5 µm | твердость: HV 1510 | состав покрытия: PVD (TiAl)N + TiN; 4 µm

Рекомендации к применению: Первый выбор для обработки стали без СОЖ

P30D

HC-P30 | HC-K25 | HC-M25

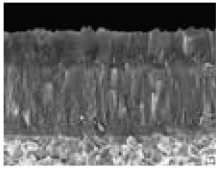

Specification: Composition: Co 10.5 %; mixed carbides 2.0 %; WC balance | Grain size: 1-2 µm | Hardness: HV30 1400 | Coating specification: CVD TiCN-Al₂O₃

Recommended application: First choice for dry machining of steels at high cutting speeds.

Состав: Co 10.5 %; соединения карбидов 2.0 %; WC ост. | размер зерна: 1-2 µm | твердость: HV30 1400 | состав покрытия: CVD TiCN-Al₂O₃

Рекомендации к применению: Первый выбор для обработки стали без СОЖ на высокой скорости резания.

P35W

HC-P35 | HC-M30

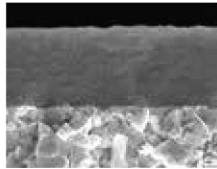

Specification: Composition: Co 10.5 %; mixed carbide 2.0 %; WC balance | Grain size: 1-2 µm | Hardness: HV30 1400 | Coating specification: PVD TiAlTaN

Recommended application: Particularly suitable for the wet machining of steels.

Состав: Co 10.5 %; соединения карбидов 2.0 %; WC ост. | размер зерна: 1-2 µm | твердость: HV30 1400 | состав покрытия: PVD TiAlTaN

Рекомендации к применению:
Отлично подойдет для обработки стали с СОЖ

P35M

HC-P35 | HC-M30



Specification: Composition: Co 12.5%; mixed carbides 2.0%; WC balance | Grain size: fine Hardness: HV30 1380 | Coating specification: CVD TiCN-Al₂O₃ + TiN; 7 µm

Recommended application: Milling Grade designed for Alloyed Steel cutting.

Состав: Co 12.5%; соединения карбидов 2.0 %; WC ост. | размер зерна: 0,8-1,3 µm | твердость: HV30 1380 | состав покрытия: CVD TiCN-Al₂O₃ + TiN; 7 µm

Рекомендации к применению:
Предназначен для обработки легированной стали

M135

HC-M35 | HC-P35



Specification: Composition: Co 11 %; other 0.75 %; WC balance | Grain size: 0.5-0.8 µm | Hardness: HV30 1500 | Coating specification: PVD TiAlTaN

Recommended application: The first choice for the machining of austenitic steels.

Состав: Co 11 %; прочее 0,75%; WC ост. | размер зерна: 0,5-0,8 µm | твердость: HV30 1500 | состав покрытия: PVD TiAlTaN

Рекомендации к применению:
Первый выбор для обработки аустенитной стали.

M3540P

HC-M40 | HC-P40

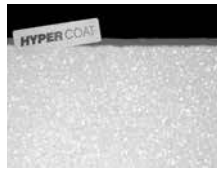

Specification: Composition: Co 12.5 %; mixed carbide 2.0 %; WC balance | Grain size: 1 µm | Hardness: HV 1380 | Coating specification: PVD (TiAl)N; 4 µm

Recommended application: Particularly suitable for the machining of stainless steels.

Состав: Co 12.5 %; соединения карбидов 2.0%; WC ост. | размер зерна: 1 µm | твердость: HV30 1380 | состав покрытия: PVD (TiAl)N; 4 µm

Рекомендации к применению:
Для обработки нержавеющей стали.

M40P

HC-M40 | HC-P40

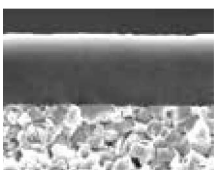

Specification: Composition: Co 12.5 %; mixed carbides 2.0 %; WC balance | Grain size: 1 µm | Hardness: HV30 1380 | Coating specification: PVD TiAlTaN

Recommended application: The first choice for the machining of austenitic steels.

Состав: Co 12.5 %; соединения карбидов 2.0%; WC ост. | размер зерна: 1 µm | твердость: HV30 1380 | состав покрытия: PVD TiAlTaN

Рекомендации к применению:
Первый выбор для обработки аустенитной стали.

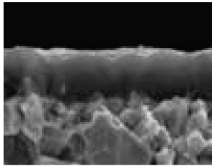
M135GP**HC-M35 | HC-P35**

Specification: Composition: Co 10.0 %; other 1.5 %; rest TC | Grain size: coarse | Hardness: HV30 1330 | Layer system: PVD TiAlTaN

Recommended application: Particularly suitable for the machining of high-alloy steels (austenitic).

Состав: Co 10.0 %; прочее 1.5%; прочие TC | размер зерна: 2,5-6,0 μm | твердость: HV30 1330 | состав покрытия: PVD TiAlTaN

Рекомендации к применению: Предназначен для обработки высоколегированной стали. (аустенитной)

K115**HC-K15**

Specification: Composition: Co 6.0 %; mixed carbide 2.0 %; WC balance | Grain size: 1 μm | Hardness: HV 1630 | Coating specification: CVD Ti(C,N) + Al₂O₃; 5 μm

Recommended application: The first choice for the machining of cast iron.

Состав: Co 6.0 %; соединения карбидов 2.0%; WC ост. | размер зерна: 1 μm | твердость: HV30 1630 | состав покрытия: CVD Ti(C,N) + Al₂O₃; 5 μm

Рекомендации к применению:

Первый выбор для обработки чугуна.

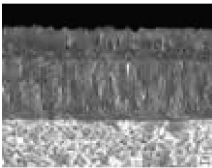
HK115**HC-K15**

Specification: Composition: Co 6.0 %; mixed carbides 2.0 %; WC balance | Grain size: 1 μm | Hardness: HV30 1600 | Coating specification: CVD TiN, MT-TiCN; Al₂O₃

Recommended application: The first choice for the machining of cast iron at high cutting speeds.

Состав: Co 6.0 %; соединения карбидов 2.0%; WC ост. | размер зерна: 1 μm | твердость: HV30 1600 | состав покрытия: CVD TiN, MT-TiCN; Al₂O₃

Рекомендации к применению:

Первый выбор для обработки чугуна при высоких скоростях резания.

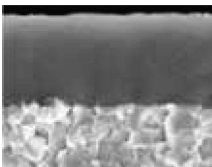
K120**HC-K20**

Specification: Composition: Co 6.0 %; mixed carbides 2.0%; WC balance | Grain size: 1 μm | Hardness: HV30 1630 | Coating specification: PVD TiAlTaN

Recommended application: Optimal for the machining of high-tensile cast iron materials when toughness is required.

Состав: Co 6.0 %; соединения карбидов 2.0%; WC ост. | размер зерна: 1 μm | твердость: HV30 1630 | состав покрытия: PVD TiAlTaN

Рекомендации к применению:

Оптимальный сплав для обработки чугунов, где требуется прочность

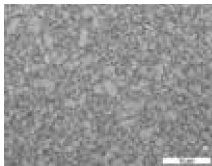
N15K**HW-N15 | HW-K15**

Specification: Composition: Co 6.0 %; WC balance | Grain size: 1 μm | Hardness: HV30 1630 | without coating

Recommended application:

The uncoated carbide grade for the machining of aluminium. It's an high wear and high heat resistant carbide with a low tendency to adhesion.

Состав: Co 6.0 %; WC ост. | размер зерна: 1 μm | твердость: HV30 1630 | без покрытия

Рекомендации к применению:

Сплав для обработки жаропрочных сталей и сплавы на основе железа

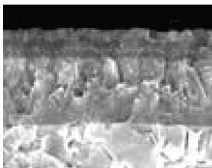
SM35**HC-S35 | HC-M35**

Specification: Composition: 10.0 % binder; WC balance | Grain size: 2 μm | Hardness: HV30 1330 | Coating specification: CVD TiCN-Al₂O₃ multi-layer

Recommended application: Particularly suitable for the machining of heat-resistant steels and iron-based alloys.

Состав: 10.0 % связка; WC ост. | размер зерна: 2 μm | твердость: HV30 1330 | состав покрытия: CVD TiCN-Al₂O₃ мульти-слой

Рекомендации к применению:

Сплав для обработки жаропрочных сплавов на основе железа.

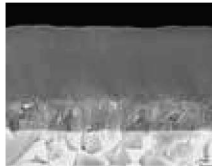
S135**HC-S35**

Specification: Composition: Co 10.0 %; WC balance | Grain size: 2 μm | Hardness: HV 1330 | Coating specification: CVD TiN +TiB₂; 4 μm

Recommended application:

Recommended for the machining of titanium materials.

Состав: Co 10.0 %; WC ост. | размер зерна: 2 μm | твердость: HV 1330 | состав покрытия: CVD TiN +TiB₂; 4 μm

Рекомендации к применению:

Сплав для обработки титановых сплавов.

H15K**HC-H15 | HC-K15**

Specification:

Composition: Co 12.0 %; WC balance | Grain size: 4 μm | Hardness: HV 1730 | Coating specification: PVD (TiAl)N; 4 μm











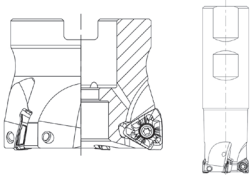

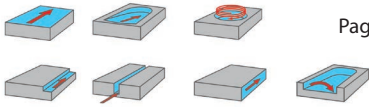
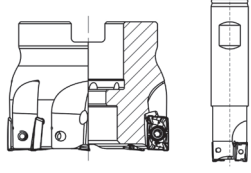

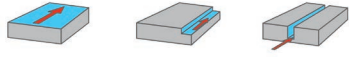
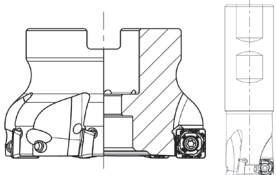

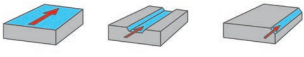
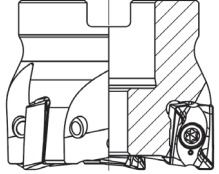
Recommended application:

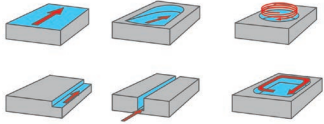
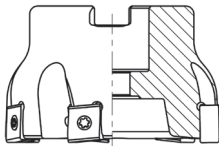

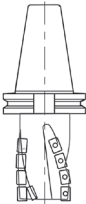

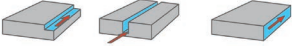
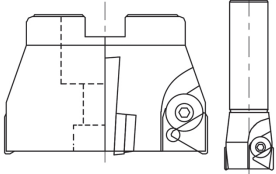

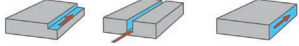
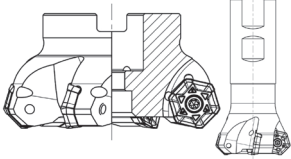

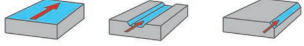

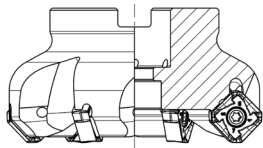

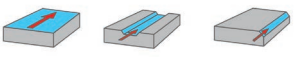
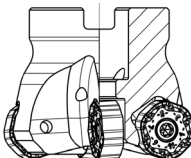

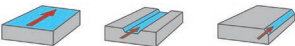
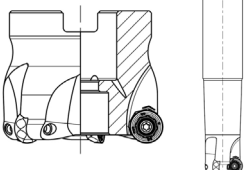

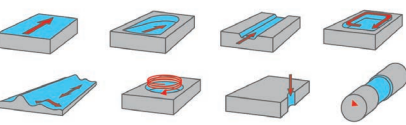
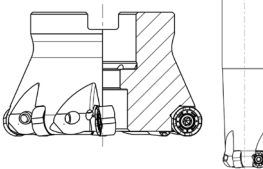
Particularly suitable for the machining of hardened steels.

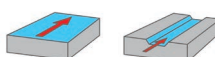
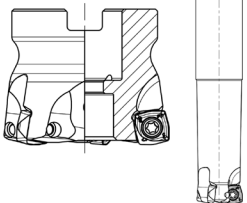
Состав: Co 12.0 %; WC ост. | размер зерна: 4 μm | твердость: HV 1730 | состав покрытия: PVD (TiAl)N; 4 μm

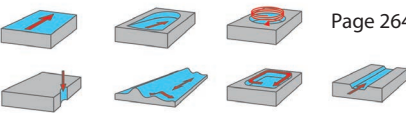
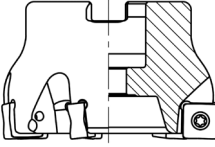

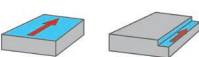
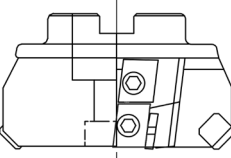
Рекомендации к применению:

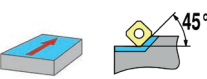
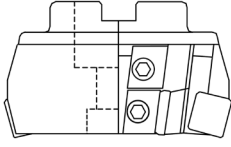
Сплав для обработки закаленных сталей

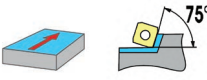
The series of tool Серия инструмента	Description Описание	Application Область применения
SM5000... 	Shouldering 3 x 90° TOKX07 TOKX09 	Ø20-63  Page 224
SM5500.. 	Shouldering 2 x 90° APKT 10 APKT / APHT 16 	Ø50-160  Page 232 Page 236
SM5010... 	Shouldering 4 x 90° SDKT 09 SDKT 12 	Ø25-80  Page 230
SM5006... 	Shouldering 4 x 90° LNKU 12 LOKU 12 	Ø50-80  Page 228
SM5060... 	Shouldering 4 x 90° LNMX 12 	 Page 228
SM5550SK... 	Shouldering 2 x 90° APKT / APHT 16 	Ø50-80  Page 240
SM5005... 	Shouldering 3 x 90° TPKN / TPKR 16 TPKN / TPKR 22 	Ø25-250  Page 242 Page 246
FM1000.... 	Face milling 6 x 45° HPKT 06 HOKT 06 HPCT 06 HOCT 06 	Ø40-125  Page 248

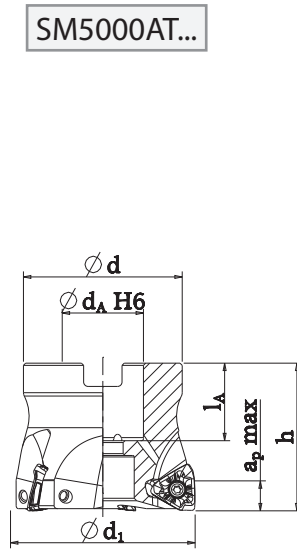
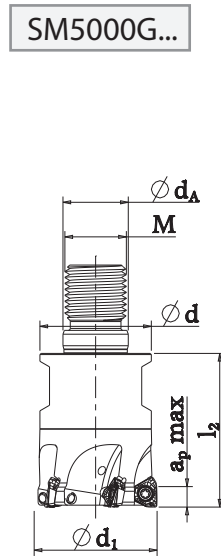
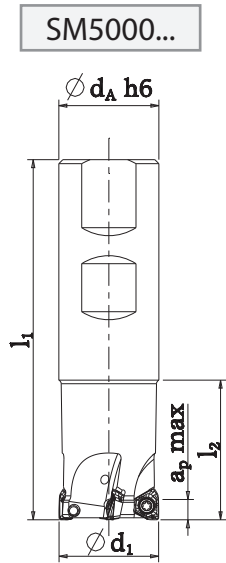
The series of tool Серия инструмента	Description Описание		Application Область применения
FM1080.... 	Face milling 8 x 45° SOKU 12 SOKU 15	 Ø40-160	 Page 250
FM1022... 	Face milling 12 x 45° HNKU 08 HOKU 08	 Ø40-125	 Page 254
P3000... 	Form milling RPMX 10/12 RDHX 10/12 RPHX 10/12 RDHW 10/12 RPMX 16 RDHX 16 RPHX 16 RDHW 16	 Ø20-125	 Page 256
FM1088... 	Form milling RNKU 12/16 ROHU 12/16	 Ø160-500	 Page 260
HF9000... 	High feed cutting XPLT 07 XDLX 10 XDLT 10 XOLT 13	 Ø16-63	 Page 264
FM1090... 	Face milling 8 x 88° SNMX 12	 Ø50-250	 Page 252
FM1200... 	Face milling 4 x 45° SEKN 12 SEKR 12 SEKR 15	 Ø50-250	 Page 266
FM1202... 	Face milling 4 x 75° SPKN 12 SPKR 12	 Ø40-500	 Page 268



Art./Apr.	d1 (mm)	l1 (mm)	l2 (mm)	h (mm)	d (mm)	dA (mm)	a _p (mm)	z	α _R (°)		
SM5000.20.07.25.077.3	20	77	25	-	-	20	5	3	1.4	TOKX 07	24645
SM5000.25.07.34.090.4	25	90	34	-	-	25		4	1.2	TOKX 07	24645
SM5000.32.07.40.102.5	32	102	40	-	-	32		5	0.8	TOKX 07	24645
SM5000G.20.07.052.M10.3	20	-	-	52	18	M10		3	1.4	TOKX 07	24645
SM5000G.25.07.057.M12.4	25	-	-	57	21	M12		4	1.2	TOKX 07	24645
SM5000G.32.07.063.M16.5	32	-	-	63	29	M16		5	0.8	TOKX 07	24645
SM5000AT.40.07.16.5	40	-	-	40	38	16		5	0.6	TOKX07	24645
SM5000AT.50.07.22.6	50	-	-	40	43	22		6	0.5	TOKX07	24645
SM5000.32.09.40.102.3	32	102	40	-	-	32		8	3	1.1	TOKX09
SM5000AT.40.09.16.4	40	-	-	40	38	16	4		0.8	TOKX09	77613
SM5000AT.50.09.22.5	50	-	-	40	43	22	5		0.5	TOKX09	77613
SM5000AT.63.09.22.6	63	-	-	40	48	22	6		0.5	TOKX09	77613

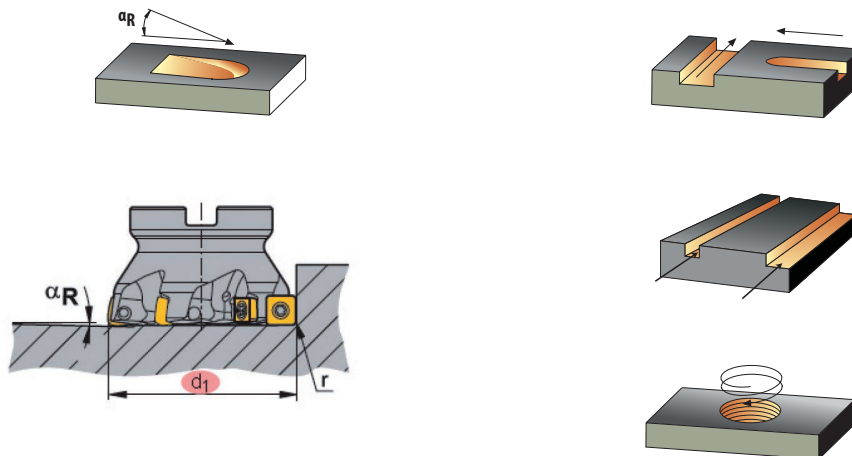

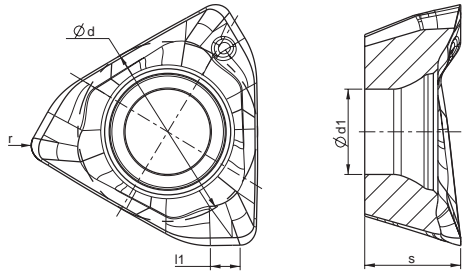

P	●	●	●	●	○	○	○									
M	○	○	○	○	●	●	●	●							●	
K		○							●	●	●	○				○
N													●			
S															●	●
H																●

Art. / Apr.	d (mm)	s (mm)	r (mm)	d1 (mm)	l1 (mm)	P3530M	P30D	P35M	P35W	M135	M3540P	M40P	M135GP	K115	HK115	K120	N15K	SM35	S135	H15K	
TOKX 070305PDER MR	5.9	3.15	0.5	2.8	1		●		●												
TOKX 070305PDER M-AF	5.9	3.15	0.5	2.8	1							●							●		
TOKX 070308PDER MR	5.9	3.15	0.8	2.8	1		●		●												
TOKX 070308PDER M-AF	5.9	3.15	0.8	2.8	1							●							●		
TOKX 09T308PDER MR	9.525	3,8	0,8	3,4	1,5		●		●												
TOKX 09T308PDER M-AF	9.525	3,8	0,8	3,4	1,5							●							●		
TOKX 09T312PDER MR	9.525	3,8	1,2	3,4	1,5		●		●												
TOKX 09T312PDER M-AF	9.525	3,8	1,2	3,4	1,5							●							●		
TOKX 09T316PDER MR	9.525	3,8	1,6	3,4	1,5		●		●												
TOKX 09T316PDER M-AF	9.525	3,8	1,6	3,4	1,5							●							●		



Material
Обрабатываемые материалы

	HB	P3530M	P30D	P35M	P35W	M135	M3540P	M40P	M135GP	K115	HK115	K120	N15K	SM35	S135	H15K
P Not alloy steel - Нелегированная сталь	125-300		220-85		220-80			200-60							180-75	
Low alloy steel - Низколегированная сталь	180-350		185-70		185-60			150-60							140-60	
Alloy steel - Легированная сталь	200-325		150-60		140-60			140-60							140-60	
Stainless steel mart - Мартенситная нерж. сталь	200-240		140-60		130-60			160-60							150-60	
M Stainless steel aust - Аустенитная нерж. сталь	180-230		120-60		120-60			140-60							150-60	
S Hig. temp. alloy - Жаропрочные сплавы	200-320														50-40	
Titanium - Титановые сплавы	400-1050														50-40	

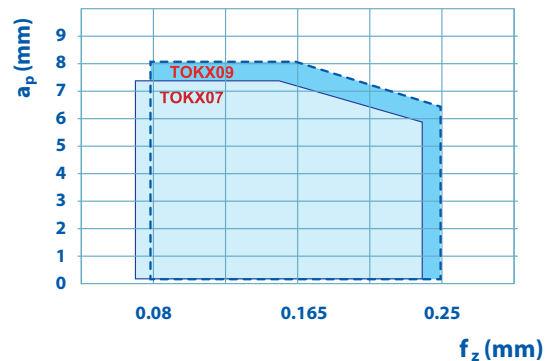
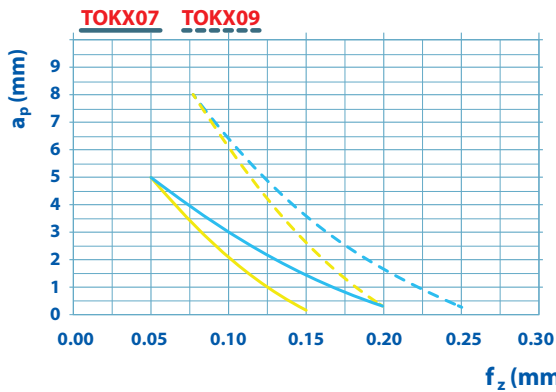

Chipbreaker
Описание стружколомов



MR
Strong cutting edge for general steel applications and hard conditions milling.
Усиленная режущая кромка для обработки всех видов сталей. Подходит для фрезерования в тяжелых условиях.



M-AF
Sharp cutting edge for general stainless steel applications and for finishing in steels.
Острая режущая кромка для полчиистой обработки нержавеющей стали. Чистовая обработка стали.

- On request / по запросу
- In stock / в наличии

SM5006AT ...

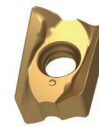
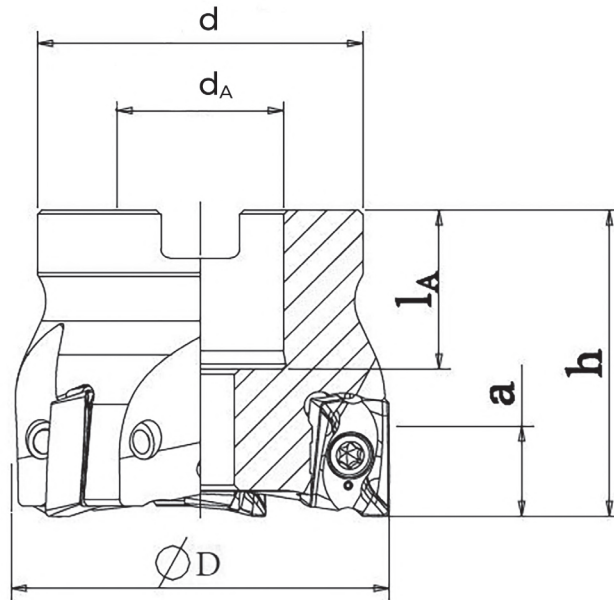

Art. / Apr.	ØD (mm)	d (mm)	lA (mm)	h (mm)	dA (mm)	a (mm)	z			
SM5006AT.40.12.22.4	40	38	20	40/40.44*	-	22	12	4	LOKU/LNKU	11042274
SM5006AT.50.12.22.5	50	43	20	40/40.44*	-	22		5	LOKU/LNKU	11042274
SM5006AT.63.12.22.6**	63	48	21	40/40.44*	-	22		6	LOKU/LNKU	11042274
SM5006AT.80.12.27.7**	80	58	22	50/50.44*	-	27		7	LOKU/LNKU	11042274

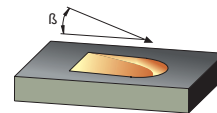
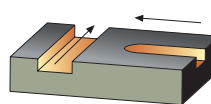
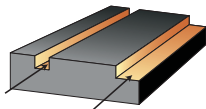
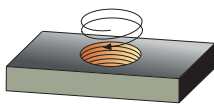

* with LOKU insert/ с пластинами LOKU
 ** On request / по запросу

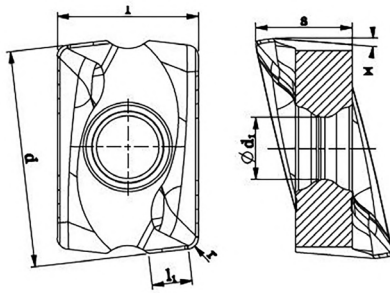

P	●	●	●	●	○	○	○										
M	○	○	○	○	●	●	●	●								●	
K		○								●	●	●	○				○
N															●		
S																●	●
H																	●

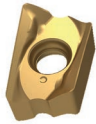

Art. / Apr.	d (mm)	s (mm)	r (mm)	d1 (mm)	l1 (mm)	l (mm)	x [°]	P3530M	P30D	P35M	P35W	M135	M3540P	M40P	M135GP	K115	HK115	K120	N15K	SM35	S135	H15K	
LNKU 120608 MR	15.27	6.78	0.8	4.4	2.84	10	-		●	●													
LNKU 120608 SCE	15.27	6.78	0.8	4.4	2.84	10	-										●						
LNKU 120608 M-AF	15.27	6.78	0.8	4.4	2.84	10	-							●									
LOKU 120608 M-AF	15.86	6.87	0.8	4.4	2.57	10	5							●									
LOKU 120608 MS	15.86	6.87	0.8	4.4	2.57	10	5														○	○	

Material

Обрабатываемые материалы

HB

		HB	P3530M	P30D	P35M	P35W	M135	M3540P	M40P	M135GP	K115	HK115	K120	N15K	SM35	S135	H15K	
P	Not alloy steel - Нелегированная сталь	125-300		220-85	220-80				200-60									
	Low alloy steel - Низколегированная сталь	180-350		185-70	185-60				150-60									
	Alloy steel - Легированная сталь	200-325		150-60	140-60				140-60									
	Stainless steel mart - Мартенситная нерж. сталь	200-240		140-60	130-60				160-60									
M	Stainless steel aust - Аустенитная нерж. сталь	180-230		120-60	120-60				140-60									
	Grey cast iron - Серый чугун												320-100					
K	Spheroidal - Сугун с шаровидным графитом												260-80					
	Hig. temp. alloy - Жаропрочные сплавы	200-320																50-40
S	Titanium - Титановые сплавы	400-1050																50-40

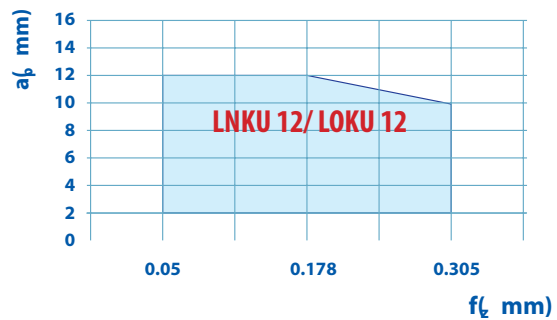
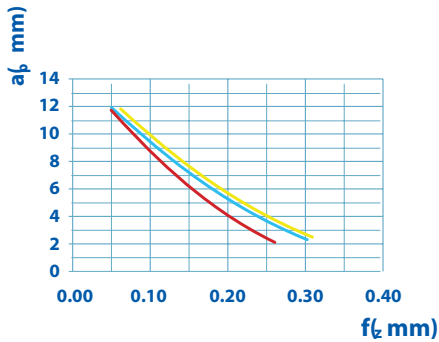

Chipbreaker

Описание стружколомов



MR

Strong cutting edge for general steel applications and hard conditions milling.

Усиленная режущая кромка для обработки всех видов сталей. Подходит для фрезерования в тяжелых условиях.



SCE

Strong cutting edge for cast iron applications.

Усиленная режущая кромка для обработки чугунов.



M-AF

Sharp cutting edge for general stainless steel applications and for finishing in steels.

Острая режущая кромка для получистовой обработки нержавеющей стали. Чистовая обработка стали.



MS

Stable cutting edge for dedicated exotic materials and titanium.

Получистовая обработка жаропрочных сплавов и титана.

- On request / по запросу
- In stock / в наличии

SM5060AT...

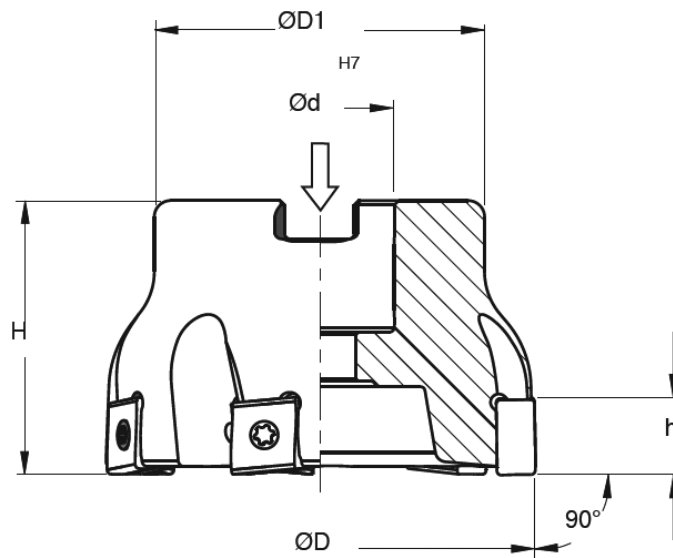

Art. / Apr.	ØD (mm)	Ød (mm)	ØD1 (mm)	H (mm)	h (mm)	Z (mm)	kg	Nm	ISO 6462	1313	1240P	5615P
S5060AT.50.22.5	50	22	42	40	12	5	0,30	3,8÷5,0	A	1313	1240P	5615P
S5060AT.50.22.6	50	22	42	40	12	5	0,29	3,8÷5,0	A			
S5060AT.63.22.6	63	22	48	40	12	6	0,51	3,8÷5,0	A			
S5060AT.63.22.8	63	22	48	40	12	8	0,50	3,8÷5,0	A			
S5060AT.80.27.7	80	27	60	50	12	7	1,00	3,8÷5,0	A			
S5060AT.80.27.10	80	27	60	50	12	10	1,00	3,8÷5,0	A			
S5060AT.100.32.9	100	32	80	50	12	9	1,66	3,8÷5,0	A			
S5060AT.100.32.13	100	32	80	50	12	13	1,64	3,8÷5,0	A			
S5060AT.125.40.11	125	40	95	63	12	11	3,20	3,8÷5,0	A-B			
S5060AT.125.40.17	125	40	95	63	12	17	3,17	3,8÷5,0	A-B			
S5060AT.160.40.12	160	40	115	63	12	12	4,00	3,8÷5,0	C-D	-		
S5060AT.160.40.19	160	40	115	63	12	19	3,98	3,8÷5,0	C-D	-		

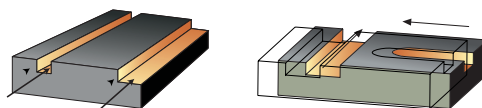

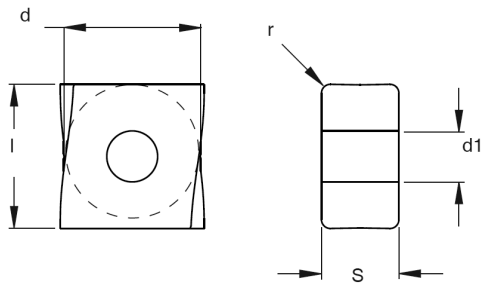

P	●	●	●	●	○	○	○								
M	○	○	○	○	●	●	●	●					●		
K		○							●	●	●	○			○
N													●		
S													●	●	
H															●



Art. / Арт.	d (mm)	s (mm)	r (mm)	d1 (mm)	l (mm)	a [°]	P3530M	P30D	P35M	P35W	M135	M3540P	M40P	M135GP	K115	HK115	K120	N15K	SM35	S135	H15K	
LNMX 131308 MR	13.0	7.0	0.8	4.6	13	-		●	●													
LNMX 131308 SCE	13.0	7.0	0.8	4.6	13	-									●							

Material	Обработываемые материалы	HB	P3530M	P30D	P35M	P35W	M135	M3540P	M40P	M135GP	K115	HK115	K120	N15K	SM35	S135	H15K
P	Not alloy steel - Нелегированная сталь	125-300		230	220						230						
	Low alloy steel - Низколегированная сталь	180-350		190	180						180						
	Alloy steel - Легированная сталь	200-325		170	180						160						
	Stainless steel mart - Мартенситная нерж. сталь	200-240		120							120						
M	Stainless steel aust - Аустенитная нерж. сталь	180-230		100	90												
K	Grey cast iron - Серый чугун	200-320		220							280						
	Spheroidal - Сугун с шаровидным графитом	400-1050		180							260						

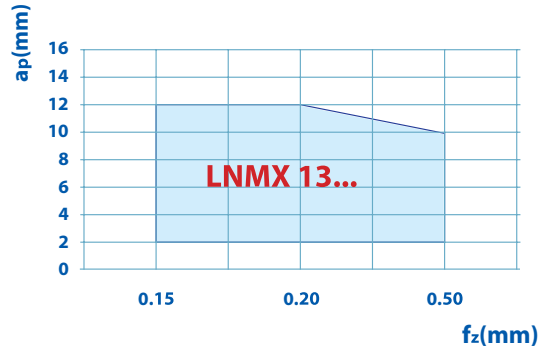
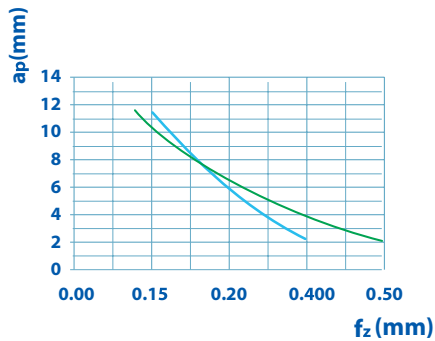

Chipbreaker

Описание стружколомов



MR

Strong cutting edge for general steel applications and hard conditions milling.
Усиленная режущая кромка для обработки всех видов сталей. Подходит для фрезерования в тяжелых условиях.







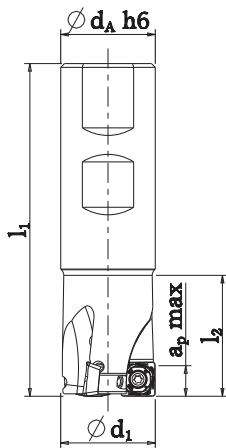
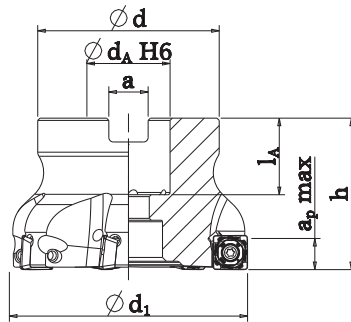
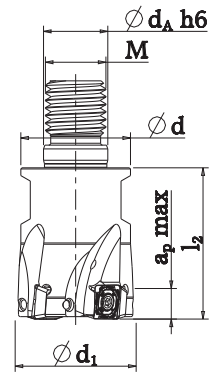

SCE

Strong cutting edge for cast iron applications.
Усиленная режущая кромка для обработки чугунов.

- On request / по запросу
- In stock / в наличии

SM5010...

SM5010AT...

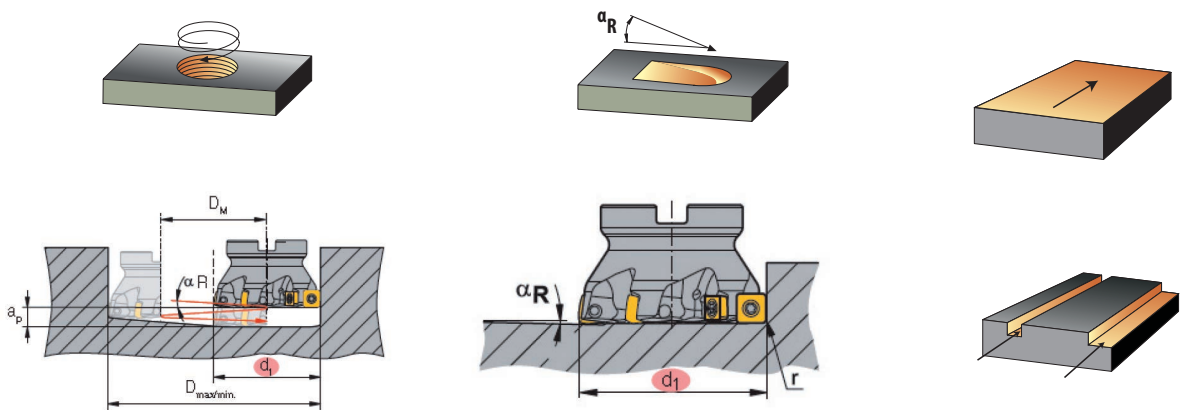
SM5010G...

Art. / Apr.	d1 (mm)	l1 (mm)	l2 (mm)	h (mm)	d (mm)	dA (mm)	z	a (mm)	D _{max} (mm)	D _{min} (mm)	α _R [°]		
SM5010.25.009.32.088.3	25	88	32	-	-	25	3	8	48	37	4.4		
SM5010.32.009.40.100.4	32	100	40	-	-	32	4		62	47	2.2		
SM5010G.25.09.M12.3	25	-	35	-	-	12.5	3		48	37	4.4		
SM5010G.32.09.M16.4	32	-	40	-	-	17	4		62	47	2.2		
SM5010AT.40.009.16.5	40	-	-	40	38	16	5		78	63	0.75		
SM5010AT.50.009.22.6	50	-	-	40	43	22	6		98	83	0.5		
SM5010AT.63.009.22.7	63	-	-	40	48	22	7		124	109	0.35		
SM5010AT.80.009.27.9	80	-	-	50	58	27	9		158	143	0.25		
SM5010.032.12.40.100.3	32	100	40	-	-	32	3	10	62	41	2.0		
SM5010AT.040.12.16.4	40	-	-	40	38	16	4		78	57	2.0		
SM5010AT.050.12.22.5	50	-	-	40	43	22	5		98	77	1.2		
SM5010AT.063.12.22.6	63	-	-	40	48	22	6		124	103	0.7		
SM5010AT.080.12.27.7	80	-	-	50	58	27	7		158	137	0.6		

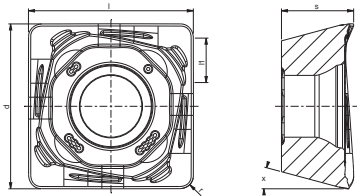

D_{max} [mm] = maximum diameter for flat bottom ground
 D_{min} [mm] = minimum hole diameter
 $D_M = D_{max} - d_1$ or $D_{min} - d_1$



P	●	●	●	●	○	○	○										
M	○	○	○	○	●	●	●	●								●	
K		○									●	●	●	○			○
N															●		
S																●	●
H																	●



Art. / Apr.	d (mm)	s (mm)	r (mm)	d1 (mm)	l1 (mm)	l (mm)	X (°)	P3530M	P30D	P35M	P35W	M135	M3540P	M40P	M135GP	K115	HK115	K120	N15K	SM35	ST35	HT5K	
SDKT 09T308SR MR	9	3.97	0.8	3.4	2.5	9	15		●		●												
SDKT 09T308SR M-AF	9	3.97	0.8	3.4	2.5	9	15							●							●	●	
SDKT 09T308SR SCE	9	3.97	0.8	3.4	2.5	9	15										●						
SDHT 09T308FR M-F	9	3.97	0.8	3.4	2.5	9	15												●				
SDKT 120508SR MR	12.3	5	0.8	4.7	2.5	12.3	15		●		●												
SDKT 120508SR M-AF	12.3	5	0.8	4.7	2.5	12.3	15							●							●	●	
SDKT 120508SR SCE	12.3	5	0.8	4.7	2.5	12.3	15										●						
SDHT 120508FR M-F	12.3	5	0.8	4.7	2.5	12.3	15												●				

Material	Обработываемые материалы	HB	P3530M	P30D	P35M	P35W	M135	M3540P	M40P	M135GP	K115	HK115	K120	N15K	SM35	ST35	HT5K
P	Not alloy steel - Нелегированная сталь	125-300		220-85		220-80			200-60								180-75
P	Low alloy steel - Низколегированная сталь	180-350		185-70		185-60			150-60								140-60
P	Alloy steel - Легированная сталь	200-325		150-60		140-60			140-60								140-60
P	Stainless steel mart - Мартенситная нерж. сталь	200-240		140-60		130-60			160-60								150-60
M	Stainless steel aust - Аустенитная нерж. сталь	180-230		120-60		120-60			140-60								150-60
K	Cast iron - Чугун	180-250										320-100					
N	Aluminium - Алюминиевые сплавы	60-130												<2000			
S	Hig. temp. alloy - Жаропрочные сплавы	200-320													50-40	75-25	
S	Titanium - Титановые сплавы	400-1050													50-40	75-25	

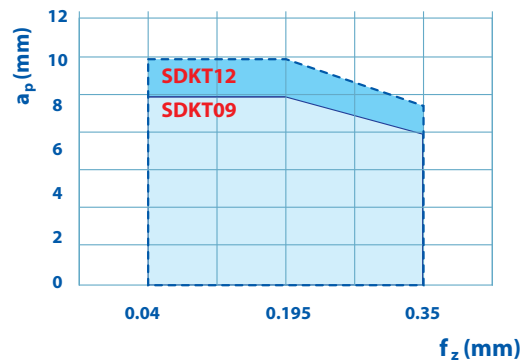
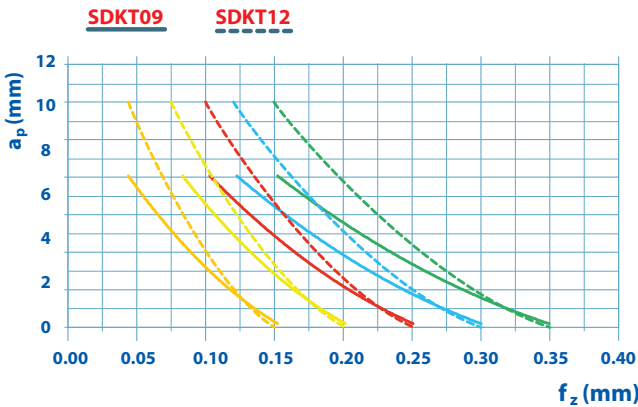

Chipbreaker

Описание стружколомов

SCE

Strong cutting edge for cast iron applications.
Усиленная режущая кромка для обработки чугунов.

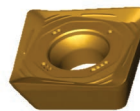

MR

Strong cutting edge for general steel applications and hard conditions milling.
Усиленная режущая кромка для обработки всех видов сталей. Подходит для фрезерования в тяжелых условиях.

M-F

Sharp cutting edge for aluminium and non-ferrous metal.
Острая режущая кромка для обработки алюминия и неметаллов.



M-AF

Sharp cutting edge for general stainless steel applications and for finishing in steels.
Острая режущая кромка для полустиковой обработки нержавеющей стали. Чистовая обработка стали.

- On request / по запросу
- In stock / в наличии

SM5500...

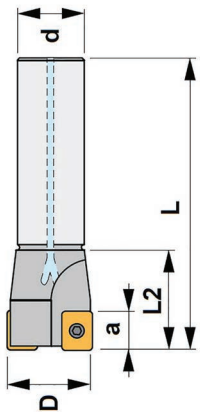

SM5500L...



SM5500W...

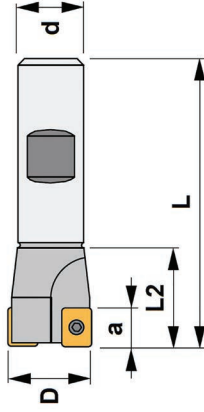

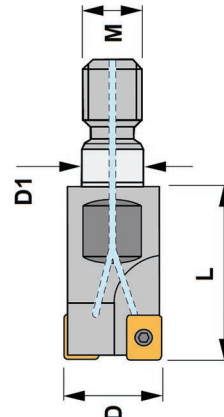

SM5500...M

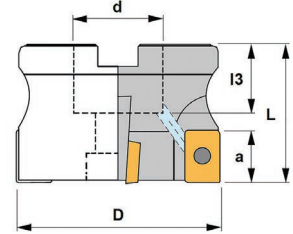

SM5500AT...

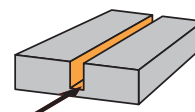
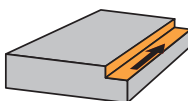
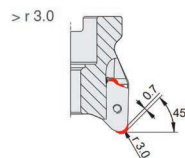
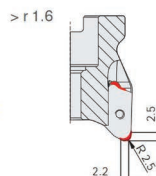
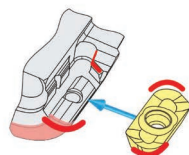

Art. / Apr.	Ø D (mm)	L (mm)	l2 (mm)	l3 (mm)	d (mm)	d1 (mm)	M	a (mm)	z			
SM5500.010.10.25.110.1	10	110	25	-	16	-	-	-	9	1	AP.. 1003..	1425
SM5500.012.10.25.110.1	12	110	25	-	16	-	-	1		AP.. 1003..	1425	
SM5500.014.10.25.110.1	14	110	25	-	16	-	-	1		AP.. 1003..	1425	
SM5500.016.10.25.110.2	16	110	25	-	20	-	-	2		AP.. 1003..	1425	
SM5500.018.10.30.110.2	18	110	30	-	20	-	-	2		AP.. 1003..	1225	
SM5500.020.10.30.125.3	20	125	30	-	20	-	-	3		AP.. 1003..	1225	
SM5500.022.10.30.125.3	22	125	30	-	20	-	-	3		AP.. 1003..	1225	
SM5500.025.10.30.125.4	25	125	30	-	25	-	-	4		AP.. 1003..	1225	
SM5500.028.10.30.125.4	28	125	30	-	25	-	-	4		AP.. 1003..	1225	
SM5500L.016.10.25.175.2	16	175	25	-	20	-	-	-	9	2	AP.. 1003..	1425
SM5500L.020.10.30.200.3	20	200	30	-	20	-	-	3		AP.. 1003..	1425	
SM5500W.012.10.25.090.1	12	90	25	-	16	-	-	-	9	1	AP.. 1003..	1225
SM5500W.016.10.25.090.2	16	90	25	-	20	-	-	2		AP.. 1003..	1425	
SM5500W.020.10.30.090.3	20	95	30	-	20	-	-	3		AP.. 1003..	1225	
SM5500W.025.10.30.090.4	25	95	30	-	25	-	-	4		AP.. 1003..	1225	
SM5500.016.10.23.M8.2	16	23	-	-	-	8,5	M8	-	9	2	AP.. 1003..	1425
SM5500.020.10.30.M10.3	20	30	-	-	-	10,5	M10	-		3	AP.. 1003..	1225
SM5500.025.10.35.M12.3	25	35	-	-	-	12,5	M12	-		3	AP.. 1003..	1225
SM5500AT.032.10.16.5	32	40	-	18	16	-	-	-	9	5	AP.. 1003..	1225
SM5500AT.040.10.16.6	40	40	-	18	16	-	-	-		6	AP.. 1003..	1225
SM5500AT.050.10.22.7	50	40	-	20	22	-	-	-		7	AP.. 1003..	1225
SM5500AT.063.10.22.9	63	50	-	20	22	-	-	-		9	AP.. 1003..	1225

Modification of cutter bodies

***To install insert with a large radius, it is necessary to make revision of the seat insert on the cutter body.**

***Для установки пластин с большим радиусом, необходимо сделать доработку посадочного места пластины на корпусе фрезы.**

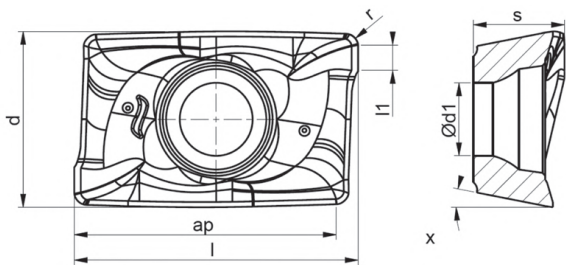

P	●	●	●	●	○	○	○										
M	○	○	○	○	●	●	●									●	
K		○								●	●	●	○				○
N															●		
S																●	●
H																	●



Art. / Apr.	l (mm)	s (mm)	d (mm)	l1 (mm)	r (mm)	d1 (mm)	χ (°)	P3530M	P30D	P35M	P35W	M135	M3540P	M40P	M135GP	K115	HK115	K120	N15K	SM35	S135	H15K	
APKT 1003PDER MR	10	3,5	6,75	1	0.5	2.8	11		●		●												
APKT 1003PDER M-AF	10	3,5	6,75	1	0.5	2.8	11							●							●		
APKT 1003PDER SCE	10	3,5	6,75	1	0.5	2.8	11										●						
APHT 100302FR M-F	10	3	6,75	2.2	0.2	2.8	11													●			
APHT 100304FR M-F	10	3	6,75	2.2	0.4	2.8	11													●			
APHT 100308FR M-F	10	3	6,75	2.2	0.8	2.8	11													●			
APKT 100308 RMR	10	3.5	6.70	0.64	0.85	2.8	11				●			●			○						
APKT 100312 RMR	10	3.5	6.70	0.5	1.2	2.8	11				●			●			○						
APKT 100316 RMR	11.5	3.4	6.70	0	1.6	2.8	11				●			●			○						
*APKT 100330 RMR	11.5	3.4	6.70	0.2	3.0	2.8	11				●			●			○						

Material
Обрабатываемые материалы

	HB	P3530M	P30D	P35M	P35W	M135	M3540P	M40P	M135GP	K115	HK115	K120	N15K	SM35	S135	H15K
P Not alloy steel - Нелегированная сталь	125-300		220-85	220-85				200-60								180-75
P Low alloy steel - Низколегированная сталь	180-350		185-70	185-70				155-60								140-60
P Alloy steel - Легированная сталь	200-325		150-60	150-60				140-60								140-60
P Stainless steel mart - Мартенситная нерж. сталь	200-240		140-60	140-60				160-60								150-60
M Stainless steel aust - Аустенитная нерж. сталь	180-230		120-60	120-60				140-60								150-60
K Cast iron - Чугун												280-80				
N Aluminium - Алюминиевые сплавы	60-130												<2000			
S Hig. temp. alloy - Жаропрочные сплавы	200-320															50-40
Titanium - Титановые сплавы	400-1050															50-40

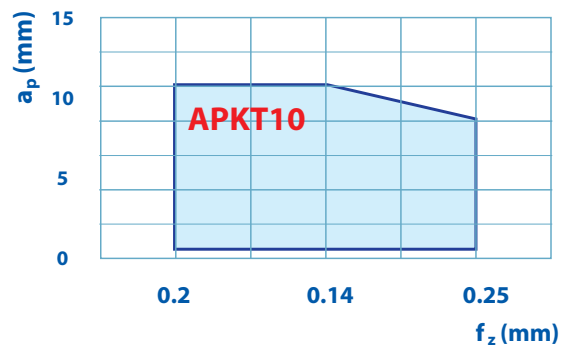
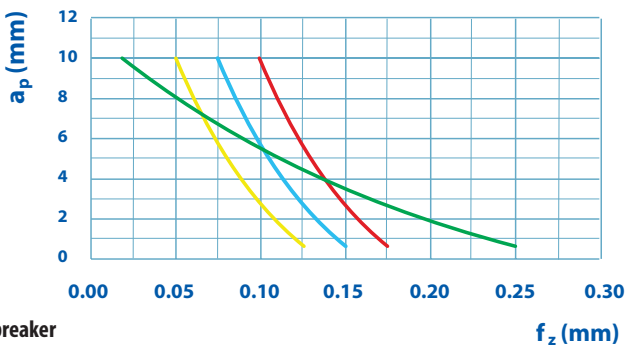

Chipbreaker

Описание стружколомов

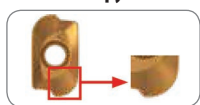

MS
Stable cutting edge for dedicated exotic materials and titanium.
Получистовая обработка жаропрочных сплавов и титана.

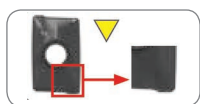

M-AF
Sharp cutting edge for general stainless steel applications and for finishing in steels.
Острая режущая кромка для получистовой обработки нержавеющей стали. Чистовая обработка стали.

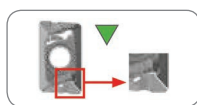

M-F
Sharp cutting edge for aluminium and nonferrous metal.
Острая режущая кромка для обработки алюминия и неметаллов.

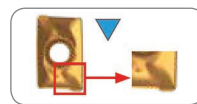

MR
Strong cutting edge for general steel applications and hard conditions milling.
Усиленная режущая кромка для обработки всех видов сталей. Подходит для фрезерования в тяжелых условиях.

- On request / по запросу
- In stock / в наличии

HIGH FEED MILLING

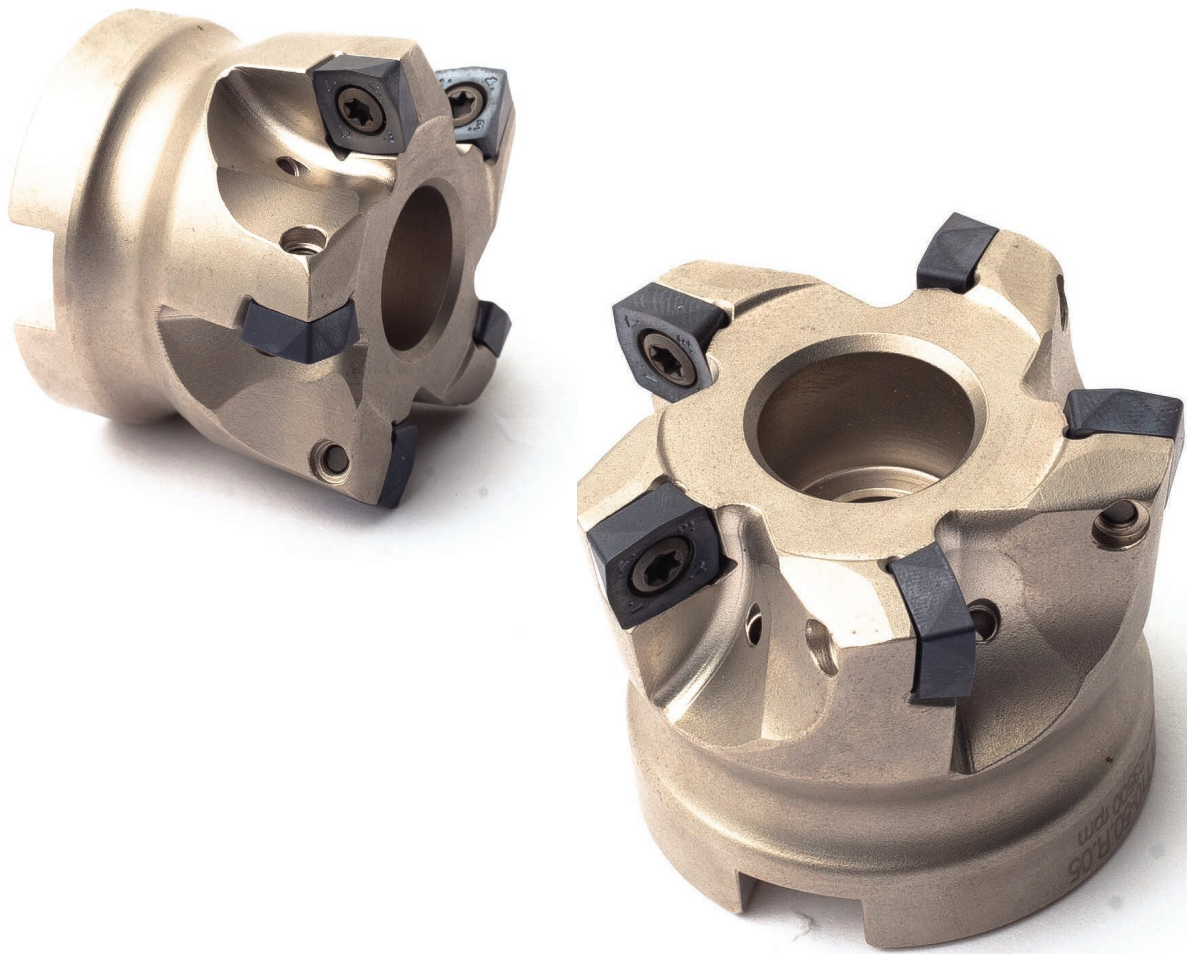

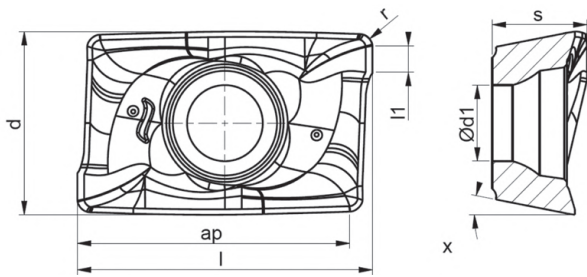

P	●	●	●	●	○	○	○												
M	○	○	○	○	●	●	●											●	
K		○											●	●	●	○			○
N																	●		
S																		●	●
H																			●



Art. / Apr.	l (mm)	s (mm)	d (mm)	ap (mm)	l1 (mm)	r (mm)	d1 (mm)	X (°)	P3530M	P30D	P35M	P35W	M135	M3540P	M40P	M135GP	K115	HK115	K120	N15K	SM35	S135	H15K	
ADKT 1505PDER MR	15.5	5.65	9.45	13.8	1.4	0.75	4.5	12	○								○							
ADKT 1505PDER M-AF	15.5	5.65	9.45	13.8	1.5	0.75	4.5	12						○								○		
ADKT 1505PDER SCE	15.5	5.65	9.45	13.8	1.5	0.75	4.5	12									○							
ADHT 1505PDER M-F	15.5	5.65	9.45	13.8	1.5	0.75	4.5	12												○				
ADHT 1505PDER MS	15.5	5.65	9.45	13.8	1.5	0.75	4.5	12														○	○	
APKT 150516 RMR	15.6	6.1	9.45	13.8	0.6	1.6	4.5	12	○					○			○					○		
APKT 150524 RMR	16.2	6.1	9.45	14.1	0.7	2.4	4.5	12	○					○			○					○		
APKT 150532 RMR	16.3	6.1	9.45	14.2	0.4	3.2	4.5	12	○					○			○					○		

Material
Обрабатываемые материалы

	HB	P3530M	P30D	P35M	P35W	M135	M3540P	M40P	M135GP	K115	HK115	K120	N15K	SM35	S135	H15K
P Not alloy steel - Нелегированная сталь	125-300	220-85					200-60									180-75
P Low alloy steel - Низколегированная сталь	180-350	185-70					150-60									140-60
P Alloy steel - Легированная сталь	200-325	150-60					140-60									140-60
P Stainless steel mart - Мартенситная нерж. сталь	200-240	140-60					160-60									150-60
M Stainless steel aust - Аустенитная нерж. сталь	180-230						140-60									150-60
K Cast iron - Чугун										320-100						
N Aluminium - Алюминиевые сплавы	60-130												<2000			
S Hig. temp. alloy - Жаропрочные сплавы	200-320														50-40	75-25
S Titanium - Титановые сплавы	400-1050														50-40	75-25

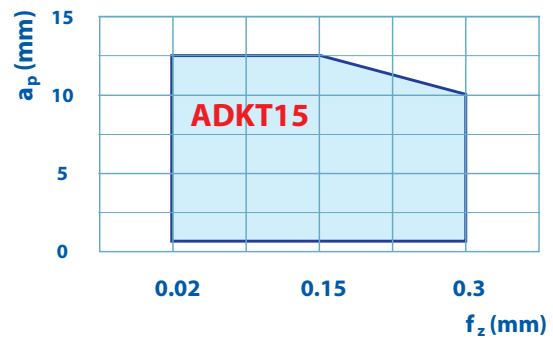
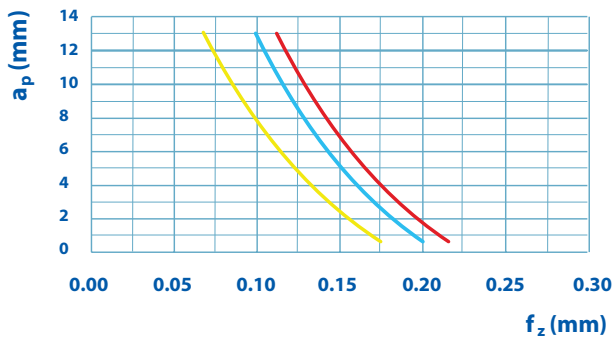

Chipbreaker
Описание стружколомов

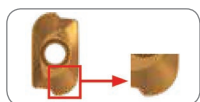

MS
Stable cutting edge for dedicated exotic materials and titanium.
Получистовая обработка жаропрочных сплавов и титана.

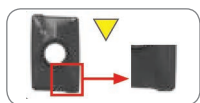

M-AF
Sharp cutting edge for general stainless steel applications and for finishing in steels.
Острая режущая кромка для получистовой обработки нержавеющей стали. Чистовая обработка стали.

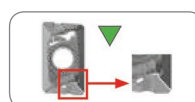

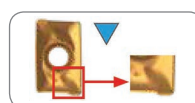

M-F
Sharp cutting edge for aluminium and nonferrous metal.
Острая режущая кромка для обработки алюминия и неметаллов.

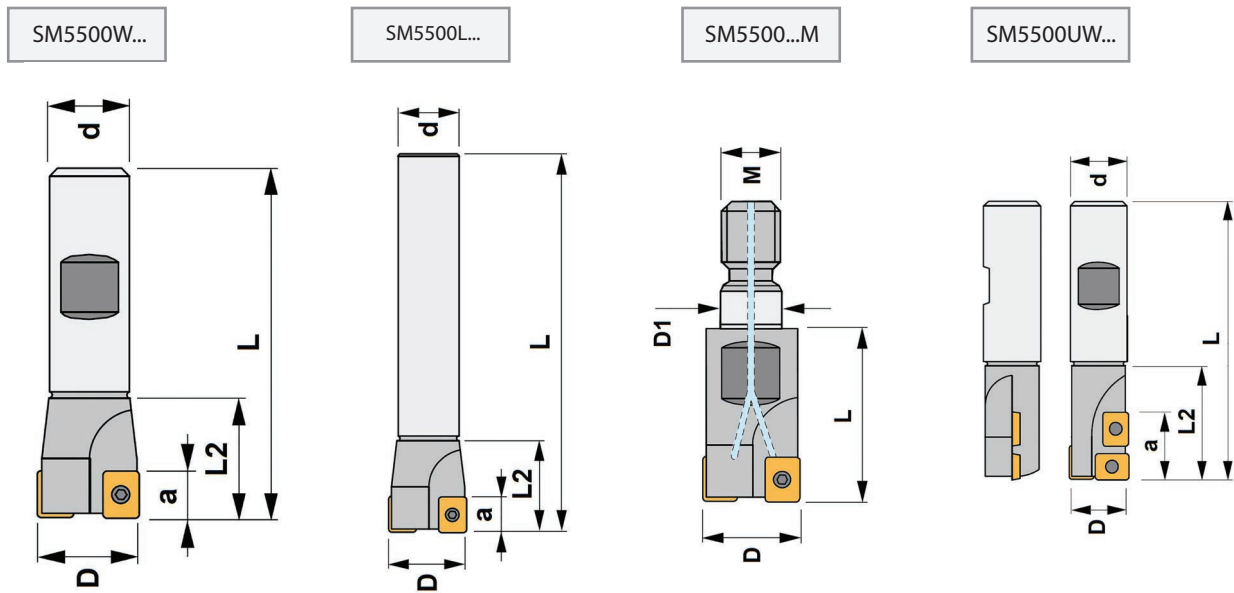

MR
Strong cutting edge for general steel applications and hard conditions milling.
Усиленная режущая кромка для обработки всех видов сталей. Подходит для фрезерования в тяжелых условиях.

- On request / по запросу
- In stock / в наличии



Art. / Apr.	ØD (mm)	l (mm)	l2 (mm)	d (mm)	M (mm)	d1 (mm)	a (mm)	z			
SM5500W.020.16.30.100.1	20	100	30	20	-	-	-	14	1	AP. 1604..	1440
SM5500W.025.16.30.100.2	25	100	30	25	-	-	2		AP. 1604..	1440	
SM5500W.032.16.35.110.3	32	110	35	32	-	-	3		AP. 1604..	1240	
SM5500W.040.16.35.110.4	40	110	35	32	-	-	4		AP. 1604..	1240	
SM5500L.020.16.35.200.1	20	200	35	20	-	-	-	14	1	AP. 1604..	1440
SM5500L.025.16.35.200.2	25	200	35	25	-	-	2		AP. 1604..	1440	
SM5500L.032.16.35.250.3	32	250	35	32	-	-	3		AP. 1604..	1240	
SM5500L.040.16.35.250.4	40	250	35	32	-	-	4		AP. 1604..	1240	
SM5500.025.16.35.M12.2	25	35	-	-	M12	12.5	-	14	2	AP. 1604..	1440
SM5500.032.16.43.M16.3	32	43	-	-	M16	17.0	-		3	AP. 1604..	1240
SM5500UW.020.10.35.090	20	90	35	20	-	-	-	14	1+1	AP. 1003..	1425
SM5500UW.025.10.50.110	25	110	50	25	-	-	-		1+1	AP. 1003..	1425
SM5500UW.032.16.50.125	32	125	50	32	-	-	-	14	1+1	AP. 1604..	1440
SM5500UW.040.16.50.125	40	125	50	32	-	-	-		1+1	AP. 1604..	1440

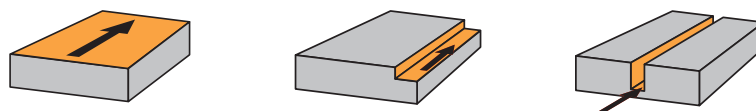

Modification of cutter bodies

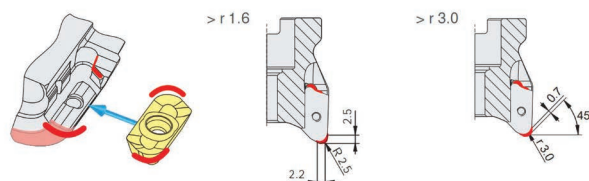

*To install insert with a large radius, it is necessary to make revision of the seat insert on the cutter body.

*Для установки пластин с большим радиусом, необходимо сделать доработку посадочного места пластины на корпусе фрезы.

SM5500AT...

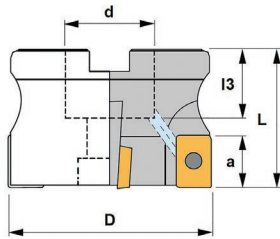

SM5500ATP...

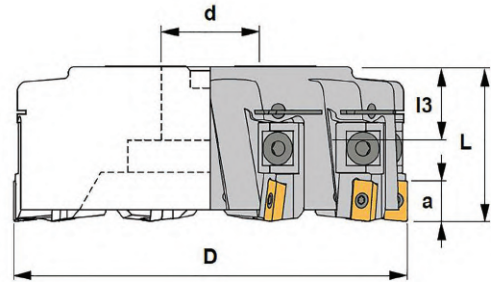

Art. / Apr.	ØD (mm)	l (mm)	d (mm)	l3 (mm)	a (mm)	z							
SM5500AT.040.16.16.4	40	40	16	18	14	4	AP.. 1604..	1240	5515	1058	-	-	-
SM5500AT.050.16.22.5	50	40	22	20		5	AP.. 1604..	1240	5515	912.10	-	-	-
SM5500AT.063.16.27.6	63	50	27	22		6	AP.. 1604..	1240	5515	912.12	-	-	-
SM5500AT.080.16.27.7	80	50	27	22		7	AP.. 1604..	1240	5515	912.12	-	-	-
SM5500AT.100.16.32.8	100	50	32	25		8	AP.. 1604..	1240	5615	912.16	-	-	-
SM5500AT.125.16.40.8	125	63	40	30		8	AP.. 1604..	1240	5615	-	-	-	-
SM5500AT.160.16.40.9	160	63	40	30		9	AP.. 1604..	1240	5615	912.52	-	-	-
SM5500ATP.160.16.40.10	160	63	40	30	14	10	AP.. 1604..	1240	5615	-	1788	6230	1460
SM5500ATP.200.16.60.12	200	63	60	40		12	AP.. 1604..	1240	5615	-	1788	6230	1460
SM5500ATP.250.16.60.16	250	63	60	40		16	AP.. 1604..	1240	5615	-	1788	6230	1460
SM5500ATP.315.16.60.20	315	63	60	40		20	AP.. 1604..	1240	5615	-	1788	6230	1460
SM5500ATP.400.16.60.22	400	63	60	40		22	AP.. 1604..	1240	5615	-	1788	6230	1460
SM5500ATP.500.16.60.28	500	63	60	40		28	AP.. 1604..	1240	5615	-	1788	6230	1460

* Корпус фрезы SM5500AT.125.16.40.8; SM5500AT.160.16.40.9 не имеет внутреннего подвода СОЖ

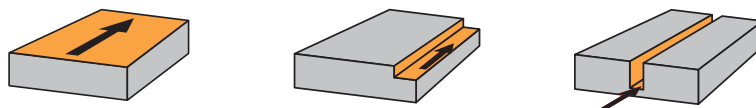

Modification of cutter bodies

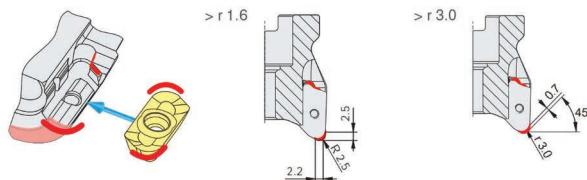

***To install insert with a large radius, it is necessary to make revision of the seat insert on the cutter body.**

*Для установки пластин с большим радиусом, необходимо сделать доработку посадочного места пластины на корпусе фрезы.

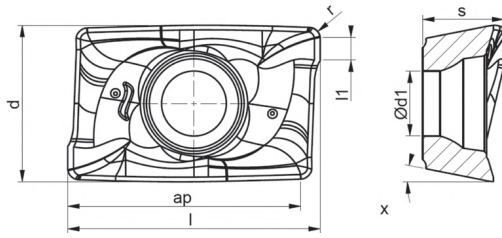

P	●	●	●	●	○	○	○										
M	○	○	○	○	●	●	●									●	
K		○								●	●	●	○				○
N															●		
S																●	●
H																	●



Art. / Apr.	l (mm)	s (mm)	d (mm)	l1 (mm)	r (mm)	d1 (mm)	X (°)	P3530M	P30D	P35W	P35M	M135	M3540P	M40P	M135GP	K115	HK115	K120	N15K	SM35	S135	H15K	
APKT 1604PDER MR	15.3	5.25	9.5	1.4	0.85	4.4	11.5		●		●												
APKT 1604PDER M-AF	15.3	5.25	9.5	1.4	0.85	4.4	11.5							●								●	
APKT 1604PDER SCE	15.3	5.25	9.5	1.4	0.85	4.4	11.5										●						
APHT 1604FR M-F	15.3	4.65	9.5	2	0.85	4.4	11.5													●			
APKT 160416 RMR	15.3	5.25	9.5	0.65	1.6	4.4	11.5				●			●			●						
*APKT 160424 RMR	15.3	5.25	9.5	0.6	2.4	4.4	11.5				●			●			○						
*APKT 160432 RMR	15.3	5.25	9.5	0.3	3.2	4.4	11.5				●			●			○				○		
*APKT 160440 RMR	15.3	5.25	9.5	0.3	4.0	4.4	11.5				○			●			○						
*APKT 160448 RMR	15.3	5.8	9.5	0.3	4.8	4.4	11.5				●			●			○						

Material
Обрабатываемые материалы

	HB	P3530M	P30D	P35W	P35M	M135	M3540P	M40P	M135GP	K115	HK115	K120	N15K	SM35	S135	H15K
P Not alloy steel - Нелегированная сталь	125-300		220-85	220-85				200-60								180-75
P Low alloy steel - Низколегированная сталь	180-350		185-70	185-70				170-60								140-60
P Alloy steel - Легированная сталь	200-325		150-60	150-60				150-60								140-60
P Stainless steel mart - Мартенситная нерж. сталь	200-240		140-60	140-60				150-60								150-60
M Stainless steel aust - Аустенитная нерж. сталь	180-230		120-60	120-60				150-60								150-60
K Cast iron - Чугун											320-100					
N Aluminium - Алюминиевые сплавы	60-130												<2000			
S Hig. temp. alloy - Жаропрочные сплавы	200-320														50-40	
Titanium - Титановые сплавы	400-1050														50-40	

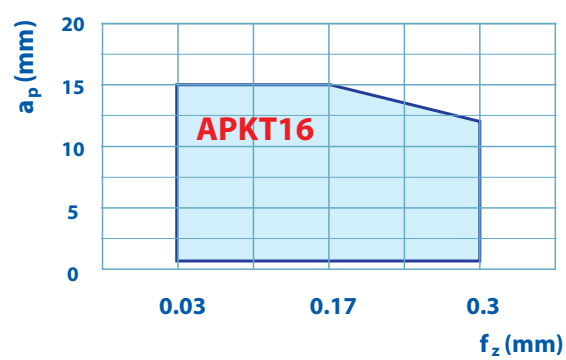
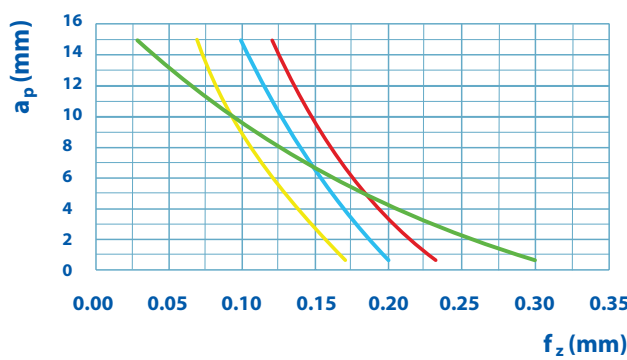

Chipbreaker

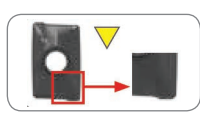

Описание стружколомов

M-AF
Sharp cutting edge for general stainless steel applications and for finishing in steels.
Острая режущая кромка для полустойковой обработки нержавеющей стали. Чистовая обработка стали.

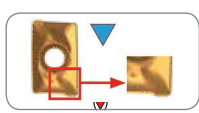
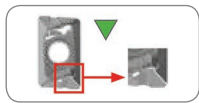

M-F

Sharp cutting edge for aluminium and nonferrous metal.
Острая режущая кромка для обработки алюминия и неметаллов.



MR

Strong cutting edge for general steel applications and hard conditions milling.
Усиленная режущая кромка для обработки всех видов сталей. Подходит для фрезерования в тяжелых условиях.

- On request / по запросу
- In stock / в наличии

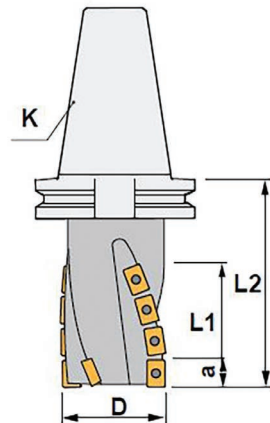
SM5550SK/BT...



Art. / Apr.	ØD (mm)	L1 (mm)	K (mm)	L2 (mm)	d (mm)	L (mm)	No	a (mm)	z			
SM5550.050.16.SK40.3	50	65	SK40	120	-	-	15	16	3	AP. 1604..	1240	5515
SM5550.050.16.SK50.3	50	65	SK50	130	-	-	15		3	AP. 1604..	1240	5515
SM5550.063.16.SK50.3	63	65	SK50	130	-	-	15		3	AP. 1604..	1240	5515
SM5550.080.16.SK50.3	80	80	SK50	140	-	-	18		3	AP. 1604..	1240	5515
SM5550.050.16.BT40.3	50	65	BT40	105	-	-	12		3	AP. 1604..	1240	5615
SM5550.050.16.BT50.3	50	65	BT50	105	-	-	15		3	AP. 1604..	1240	5615
SM5550.063.16.BT50.3	63	65	BT50	130	-	-	15		3	AP. 1604..	1240	5615
SM5550.080.16.BT50.3	80	80	BT50	140	-	-	18		3	AP. 1604..	1240	5515

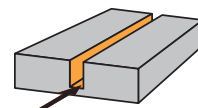
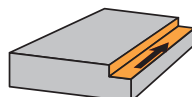

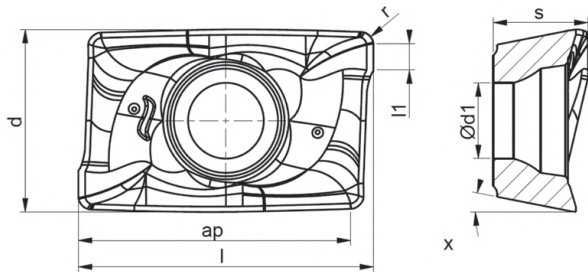

P	●	●	●	●	○	○	○												
M	○	○	○	○	●	●	●											●	
K		○									●	●	●	○					○
N																	●		
S																		●	●
H																			●

Art. / Apr.	l (mm)	s (mm)	d (mm)	l1 (mm)	r (mm)	d1 (mm)	X (°)	P3530M	P30D	P35W	P35M	M135	M3540P	M40P	M135GP	K115	HK115	K120	N15K	SM35	S135	H15K	
APKT 1604PDER MR	15.3	5.25	9.5	1.4	0.85	4.4	11.5		●		●												
APKT 1604PDER M-AF	15.3	5.25	9.5	1.4	0.85	4.4	11.5							●							●		
APKT 1604PDER SCE	15.3	5.25	9.5	1.4	0.85	4.4	11.5										●						
APHT 1604FR M-F	15.3	4.65	9.5	2	0.85	4.4	11.5													●			



Material
Обрабатываемые материалы

	Material	HB	P3530M	P30D	P35W	P35M	M135	M3540P	M40P	M135GP	K115	HK115	K120	N15K	SM35	S135	H15K	
P	Not alloy steel - Нелегированная сталь	125-300		220-85	220-85				200-60								180-75	
	Low alloy steel - Низколегированная сталь	180-350		185-70	185-70				170-60								140-60	
	Alloy steel - Легированная сталь	200-325		150-60	150-60				150-60								140-60	
	Stainless steel mart - Мартенситная нерж. сталь	200-240		140-60	140-60				150-60								150-60	
M	Stainless steel aust - Аустенитная нерж. сталь	180-230		120-60	120-60				150-60								150-60	
K	Cast iron - Чугун												320-100					
N	Aluminium - Алюминиевые сплавы	60-130															<2000	
S	Hig. temp. alloy - Жаропрочные сплавы	200-320															50-40	
	Titanium - Титановые сплавы	400-1050															50-40	

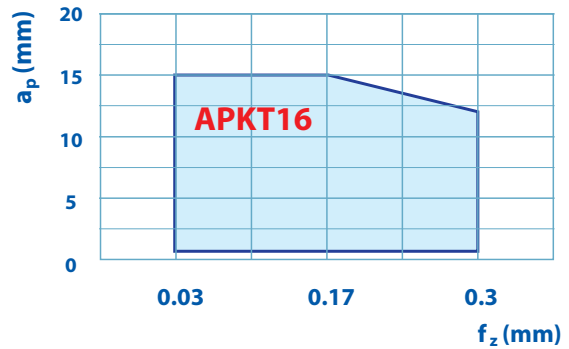
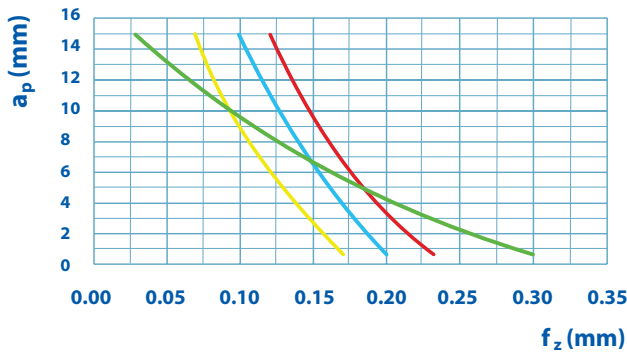

Chipbreaker

Описание стружколомов

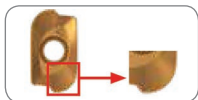

MS
Stable cutting edge for dedicated exotic materials and titanium.
Получистовая обработка жаропрочных сплавов и титана.

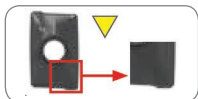

M-AF
Sharp cutting edge for general stainless steel applications and for finishing in steels.
Острая режущая кромка для получистовой обработки нержавеющей стали. Чистовая обработка стали.

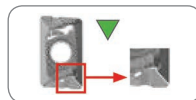

M-F
Sharp cutting edge for aluminium and nonferrous metal.
Острая режущая кромка для обработки алюминия и неметаллов.

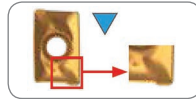

MR
Strong cutting edge for general steel applications and hard conditions milling.
Усиленная режущая кромка для обработки всех видов сталей. Подходит для фрезерования в тяжелых условиях.

- On request / по запросу
- In stock / в наличии

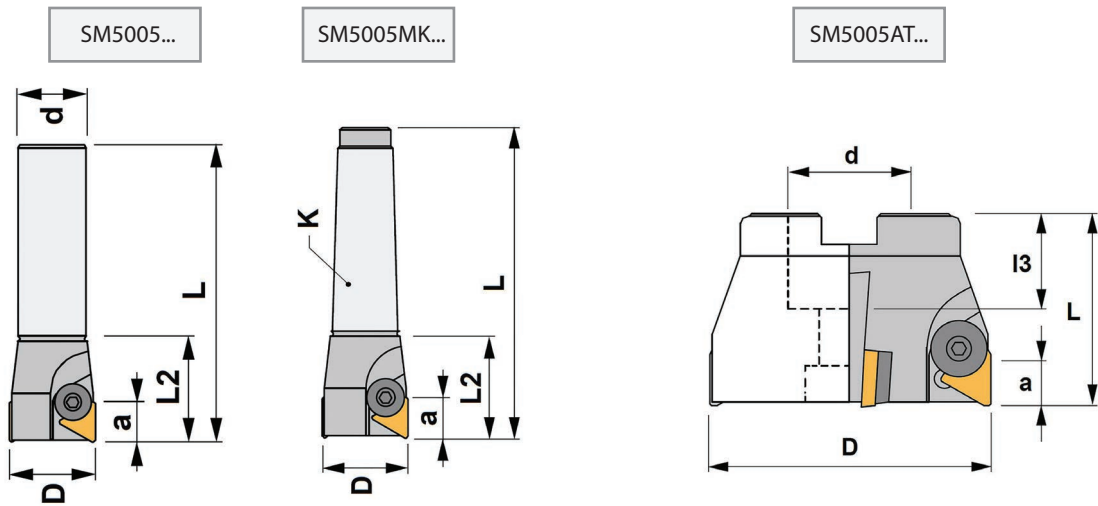

Art. / Арт.	ØD (mm)	l (mm)	l2 (mm)	l3 (mm)	d (mm)	K (mm)	a (mm)	z								
SM5005.025.16.35.110.2	25	110	35	-	25	-	-	13	2	TP. 1603..	1016	5004	2064	-	-	-
SM5005.032.16.35.125.2	32	125	35	-	32	-	2		TP. 1603..	1016	5004	2064	-	-	-	
SM5005MK.025.16.38.125.2	25	125	38	-	-	MK3	2		TP. 1603..	1016	5004	2064	-	-	-	
SM5005MK.032.16.38.125.2	32	125	38	-	-	MK3	2		TP. 1603..	1016	5004	2064	-	-	-	
SM5005MK.040.16.38.125.3	40	125	38	-	-	MK3	3		TP. 1603..	1016	5004	2064	-	-	-	
SM5005AT.040.16.16.3	40	40	-	18	16	-	-	13	3	TP. 1603..	1006	5004	2064	-	-	1058
SM5005AT.050.16.22.4	50	40	-	20	22	-	4		TP. 1603..	1016	5004	2064	-	-	912,10	
SM5005AT.050.16.22.3	50	40	-	20	22	-	3		TP. 1603..	1006	5004	2064	-	-	912,10	
SM5005AT.063.16.27.4	63	50	-	22	27	-	4		TP. 1603..	1006	5004	2064	3016	4016	912,12	
SM5005AT.080.16.32.5	80	50	-	25	32	-	5		TP. 1603..	1006	5004	2064	3016	4016	912,16	
SM5005AT.100.16.40.6	100	50	-	30	40	-	6		TP. 1603..	1006	5004	2064	3016	4016	912,20	
SM5005AT.125.16.40.6	125	63	-	30	40	-	6		TP. 1603..	1006	5004	2064	3016	4016	-	
SM5005AT.160.16.40.7	160	63	-	30	40	-	7		TP. 1603..	1006	5004	2064	3016	4016	912,52	
SM5005AT.200.16.60.8	200	63	-	40	60	-	8		TP. 1603..	1006	5004	2064	3016	4016	912,56	

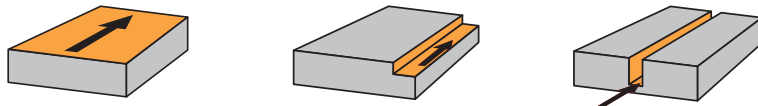

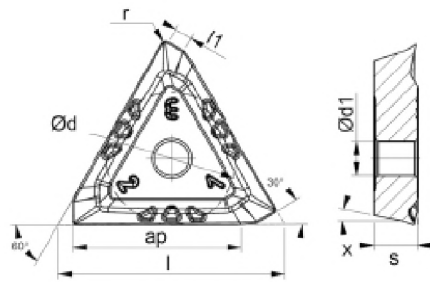

P	●	●	●	●	○	○	○												
M	○	○	○	○	●	●	●												
K		○										●	●	●	○				○
N																●			
S																		●	●
H																			●

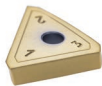

Art. / Арт.	l (mm)	s (mm)	d (mm)	ap (mm)	l1 (mm)	r (mm)	d1 (mm)	X (°)	P3530M	P30D	P35W	P35M	M135	M3540P	M40P	M135GP	K115	HK115	K120	N15K	SM35	S135	H15K	
TPKN 1603PDR MR	16.5	3.18	9.52	13.3	1.45	0.20	2.5	11.25		○		○			○									
TPKR 1603PDR M-AF	16.5	3.18	9.52	12.4	1.20	0.40	2.5	11.25		○		○			○									

Material
Обрабатываемые материалы

	HB	P3530M	P30D	P35W	P35M	M135	M3540P	M40P	M135GP	K115	HK115	K120	N15K	SM35	S135	H15K
P Not alloy steel - Нелегированная сталь	125-300	220-85	220-85	220-85	220-85	200-60	200-60									180-75
Low alloy steel - Низколегированная сталь	180-350	185-70	185-70	185-70	185-70	180-60	180-60									140-60
Alloy steel - Легированная сталь	200-325	150-60	150-60	150-60	150-60	160-60	160-60									140-60
Stainless steel mart - Мартенситная нерж. сталь	200-240	140-60	140-60	140-60	140-60	160-60	160-60									150-60
M Stainless steel aust - Аустенитная нерж. сталь	180-230	120-60	120-60	120-60	120-60	150-60	150-60									150-60
K Cast iron - Чугун										320-100						
S Hig. temp. alloy - Жаропрочные сплавы	200-320															50-40
Titanium - Титановые сплавы	400-1050															50-40

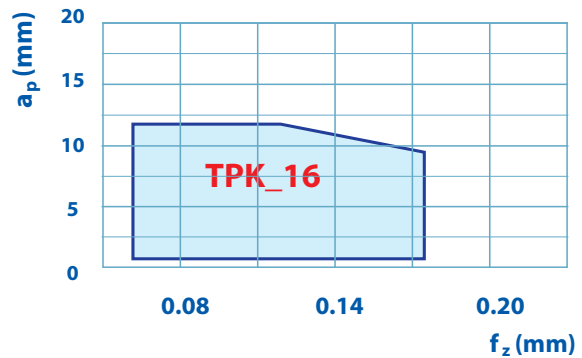
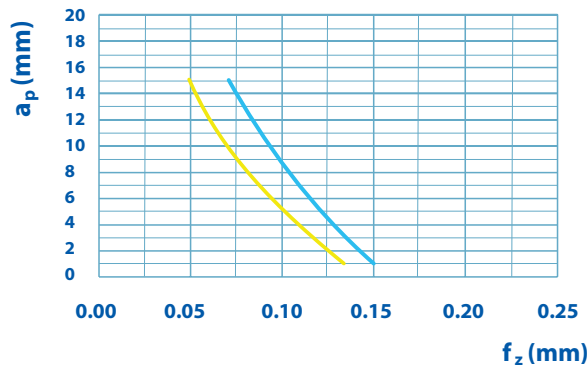

Chipbreaker
Описание стружколомов

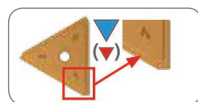

MR
Strong cutting edge for general steel applications and hard conditions milling.
Усиленная режущая кромка для обработки всех видов сталей. Подходит для фрезерования в тяжелых условиях.

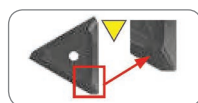

M-AF
Sharp cutting edge for general stainless steel applications and for finishing in steels.
Острая режущая кромка для получистовой обработки нержавеющей стали. Чистовая обработка стали.

- On request / по запросу
- In stock / в наличии

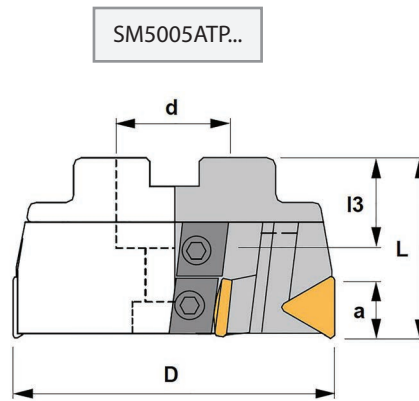

Art. / Apr.	ØD (mm)	l (mm)	l3 (mm)	d (mm)	a (mm)	z								
SM5005ATP.052.16.16.3	52	50	18	16	13	5	TP. 1603..	1460	1166	5515	6031	6032	6526	1058
SM5005ATP.063.16.22.4	63	50	20	22		6	TP. 1603..	1460	1166	5515	6031	6032	6526	912.10
SM5005ATP.080.16.27.3	80	50	22	27		5	TP. 1603..	1460	1077	5520	6433	6435	6927	912.12
SM5005ATP.100.16.32.4	100	50	25	32		7	TP. 1603..	1460	1077	5620	6433	6435	6927	912.16
SM5005ATP.125.16.40.5	125	63	30	40		7	TP. 1603..	1460	1077	5620	6433	6435	6927	-
SM5005ATP.160.16.40.6	160	63	30	40		9	TP. 1603..	1460	1077	5620	6433	6435	6927	912.52
SM5005ATP.200.16.60.8	200	63	40	60		11	TP. 1603..	1460	1077	5620	6433	6435	6927	912.56

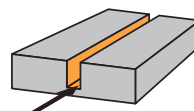
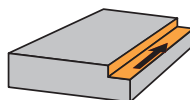

SM5005AT...

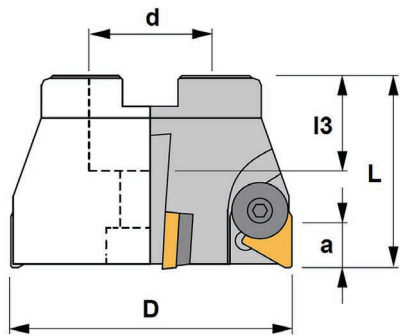

SM5005ATP...

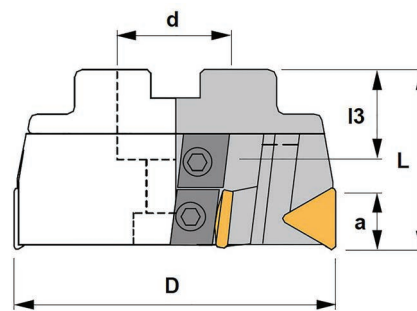

Art. / Apr.	ØD (mm)	l (mm)	l3 (mm)	d (mm)	a (mm)	z						
SM5005AT.063.22.27.3	63	50	22	27		3	TP. 2204..	1008	2088	3022	4022	912.12
SM5005AT.080.22.32.4	80	50	25	32		4	TP. 2204..	1008	2088	3022	4022	912.16
SM5005AT.100.22.40.5	100	50	30	40		5	TP. 2204..	1008	2088	3022	4022	912.20
SM5005AT.125.22.40.6	125	63	30	40		6	TP. 2204..	1008	2088	3022	4022	-
SM5005AT.160.22.40.7	160	63	30	40		7	TP. 2204..	1008	2088	3022	4022	912.52
SM5005AT.200.22.60.8	200	63	40	60		8	TP. 2204..	1008	2088	3022	4022	912.56

Art. / Apr.	ØD (mm)	l (mm)	l3 (mm)	d (mm)	a (mm)	z								
SM5005ATP.080.22.27.5	80	50	22	27		5	TP. 2204..	1077	5520	6434	6436	912.12	6942	1077
SM5005ATP.100.22.32.7	100	50	25	32		7	TP. 2204..	1077	5520	6434	6436	912.16	6942	1077
SM5005ATP.125.22.40.7	125	63	30	40		7	TP. 2204..	1077	5520	6434	6436	-	6942	1077
SM5005ATP.160.22.40.9	160	63	30	40		9	TP. 2204..	1077	5520	6434	6436	912.52	6942	1077
SM5005ATP.200.22.60.11	200	63	40	60		11	TP. 2204..	1077	5520	6434	6436	912.56	6942	1077
SM5005ATP.250.22.60.15	250	63	40	60		15	TP. 2204..	1077	5520	6434	6436	912.56	6942	1077

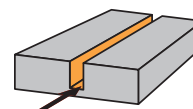
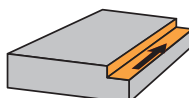

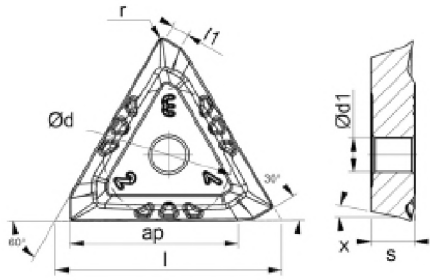

P	●	●	●	●	○	○	○												
M	○	○	○	○	●	●	●											●	
K		○										●	●	●	○				○
N																	●		
S																		●	●
H																			●



Art. / Apr.	l (mm)	s (mm)	d (mm)	ap (mm)	l1 (mm)	r (mm)	d1 (mm)	X (°)	P3530M	P30D	P35W	P35M	M135	M3540P	M40P	M135GP	K115	HK115	K120	N15K	SM35	S135	H15K	
TPKN 2204PDR MR	22.0	4.76	12.7	18.7	1.55	0.2	2.5	11.25		●		●					●							
TPKR 2204PDR M-AF	22.0	4.76	12.7	17.7	1.65	0.3	2.5	11.25	●					●	●							○		

Material
Обрабатываемые материалы

HB

		125-300	220-85/220-85	220-85	200-60/200-60																				
P	Not alloy steel - Нелегированная сталь																							180-75	
	Low alloy steel - Низколегированная сталь																								140-60
	Alloy steel - Легированная сталь																								140-60
	Stainless steel mart - Мартенситная нерж. сталь																								150-60
M	Stainless steel aust - Аустенитная нерж. сталь																								150-60
K	Cast iron- Чугун																								
S	Hig. temp. alloy - Жаропрочные сплавы																								50-40
	Titanium - Титановые сплавы																								

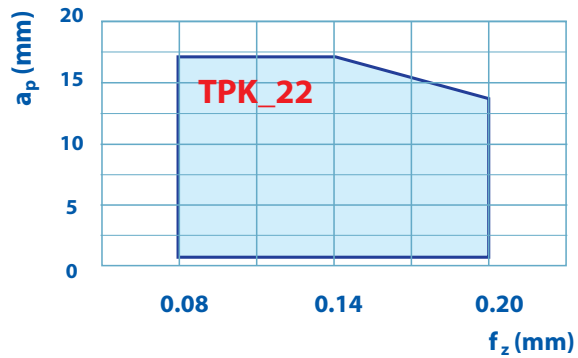
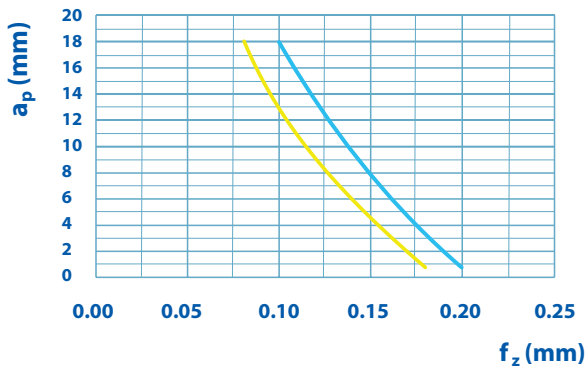

Chipbreaker
Описание стружколомов

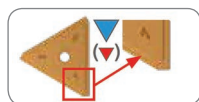

MR
Strong cutting edge for general steel applications and hard conditions milling.
Усиленная режущая кромка для обработки всех видов сталей. Подходит для фрезерования в тяжелых условиях.

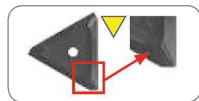

M-AF
Sharp cutting edge for general stainless steel applications and for finishing in steels.
Острая режущая кромка для полустойкой обработки нержавеющей стали. Чистовая обработка стали.

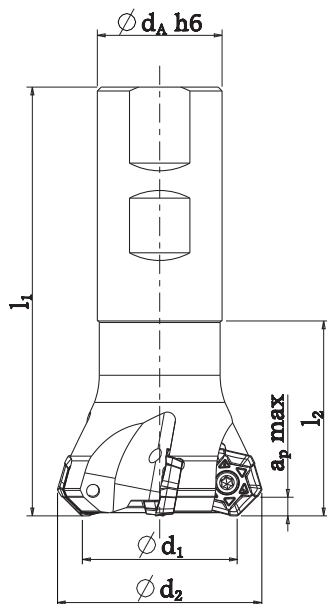

- On request / по запросу
- In stock / в наличии

FM1000W...

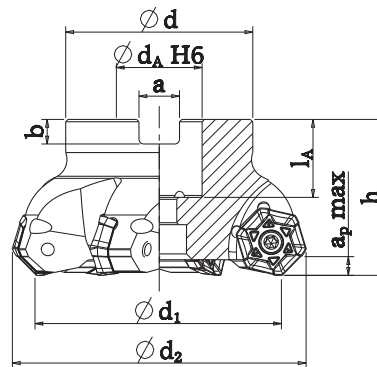

FM1000AT...

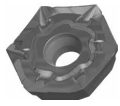

Art. / Арт.	ϕd_1 (mm)	ϕD_2 (mm)	l_1 (mm)	l_2 (mm)	h (mm)	d (mm)	d_A (mm)	a (mm)	z		
FM1000W.040.06.50.110.4	40	52.2	110	50	-	-	32		4	HO/HP 06	1345432
FM1000AT.040.06.16.4	40	52.2	-	-	40	38	16		4	HO/HP 06	1345432
FM1000AT.050.06.22.5	50	62.2	-	-	40	43	22	4,5	5	HO/HP 06	1345432
FM1000AT.063.06.22.6	63	75,2	-	-	40	48	22		6	HO/HP 06	1345432
FM1000AT.080.06.27.7	80	92,2	-	-	50	58	27		7	HO/HP 06	1345432
FM1000AT.100.06.32.9	100	112,2	-	-	50	78	32		9	HO/HP 06	1345432
FM1000AT.125.06.40.10	125	137,2	-	-	63	88	40		10	HO/HP 06	1345432

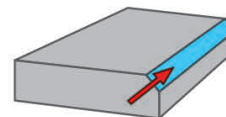
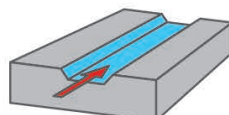
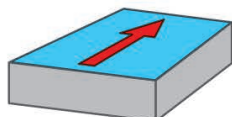

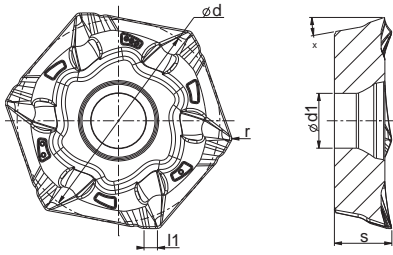

P	●	●	●	●	○	○	○									
M	○	○	○	○	●	●	●	●							●	
K		○								●	●	●	○			○
N													●			
S														●	●	
H																●



Art. / Apr.	d (mm)	s (mm)	r (mm)	d1 (mm)	l1 (mm)	X (°)	P3530M	P30D	P35M	P35W	M135	M3540P	M40P	M135GP	K115	HK115	K120	N15K	SM35	S135	H15K	
HPKT 0604AZER MR	16.3	4.5	0.4	4.4	1.7	11		●		●												
HPKT 0604AZER M-AF	16.3	4.5	0.4	4.4	1.7	11														●		
HPCT 0604AZER M-F	16.3	4.5	0.4	4.4	1.7	11												●				
HOKT 0604AZER MR	16.3	4.5	0.4	4.4	1.7	11		●		●												
HOCT 0604AZER M-AF	16.3	4.5	0.4	4.4	1.7	11							●							●		

Material
Обрабатываемые материалы

		HB	P3530M	P30D	P35M	P35W	M135	M3540P	M40P	M135GP	K115	HK115	K120	N15K	SM35	S135	H15K	
P	Not alloy steel - Нелегированная сталь	125-300		220-85		220-80			200-60								180-75	
	Low alloy steel - Низколегированная сталь	180-350		185-70		185-60			150-60								140-60	
	Alloy steel - Легированная сталь	200-325		150-60		140-60			140-60								140-60	
	Stainless steel mart - Мартенситная нерж. сталь	200-240		140-60		130-60			160-60								150-60	
M	Stainless steel aust - Аустенитная нерж. сталь	180-230		120-60		120-60			140-60								150-60	
	Aluminium - Алюминиевые сплавы	60-130												<2000				
S	Hig. temp. alloy - Жаропрочные сплавы	200-320															50-40	
	Titanium - Титановые сплавы	400-1050															50-40	

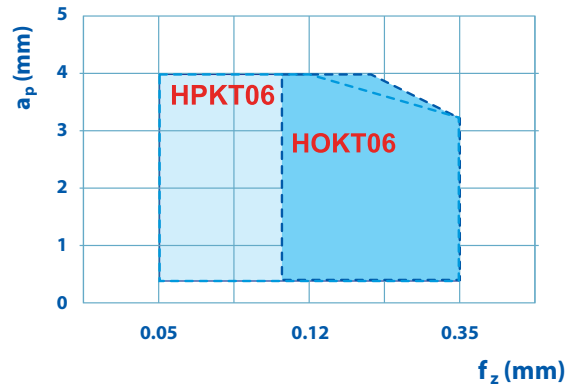
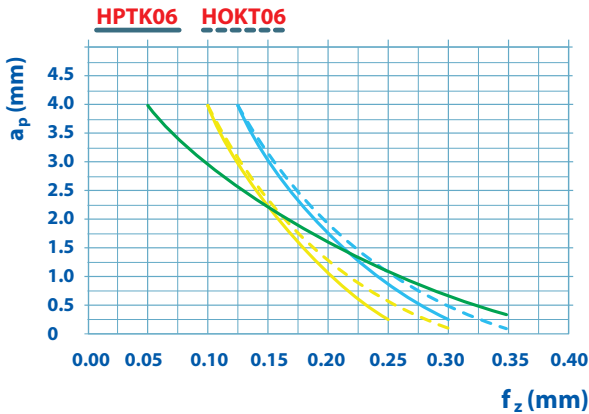

Chipbreaker

Описание стружколомов



MR
Strong cutting edge for general steel applications and hard conditions milling.
Усиленная режущая кромка для обработки всех видов сталей. Подходит для фрезерования в тяжелых условиях.



M-AF
Sharp cutting edge for general stainless steel applications and for finishing in steels.
Острая режущая кромка для получения чистовой обработки нержавеющей стали. Чистовая обработка стали.





M-F
Sharp cutting edge for aluminium and non-ferrous metal.
Острая режущая кромка для обработки алюминия и неметаллов.

- On request / по запросу
- In stock / в наличии

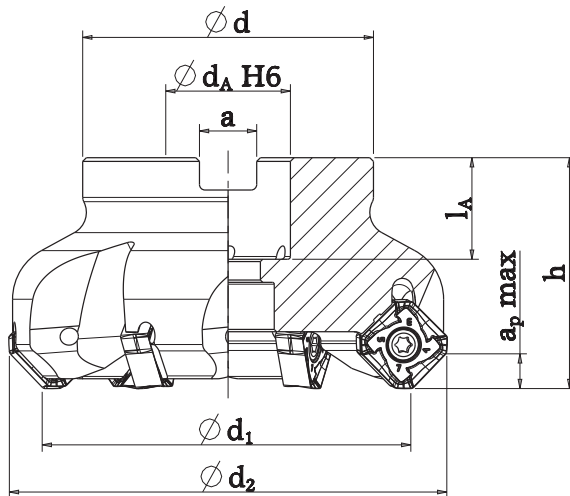
FM1080AT...



Art. / Apr.	$\varnothing d_1$ (mm)	$\varnothing d_2$ (mm)	h (mm)	d (mm)	dA (mm)	a (mm)	z		
FM1080AT.040.13.16.4	40	52.4	45	38	16	6	4	SOKU 12	11042274
FM1080AT.050.13.22.5	50	62.4	45	43	22		5	SOKU 12	11042274
FM1080AT.063.13.22.6	63	75.4	45	48	22		6	SOKU 12	11042274
FM1080AT.080.13.27.8	80	92.4	50	58	27		8	SOKU 12	11042274
FM1080AT.100.13.32.10	100	112.4	50	78	32		10	SOKU 12	11042274
FM1080AT.125.13.40.12	125	137.4	63	88	40		12	SOKU 12	11042274
FM1080AT.040.15.16.4	40	52.4	45	38	16	8	4	SOKU 15	1345431
FM1080AT.050.15.22.4	50	62.4	45	43	22		4	SOKU 15	1345431
FM1080AT.063.15.22.5	63	75.4	45	48	22		5	SOKU 15	1345431
FM1080AT.080.15.27.6	80	92.4	50	58	27		6	SOKU 15	1345431
FM1080AT.100.15.32.7	100	112.4	50	78	32		7	SOKU 15	1345431
FM1080AT.125.15.40.8	125	137.4	63	88	40		8	SOKU 15	1345431
FM1080AT.160.15.40.10	160	172.4	63	104	40		10	SOKU 15	1345431

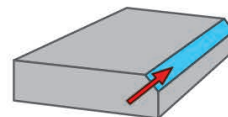
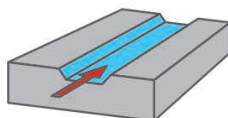
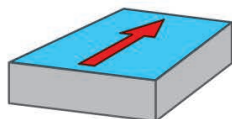

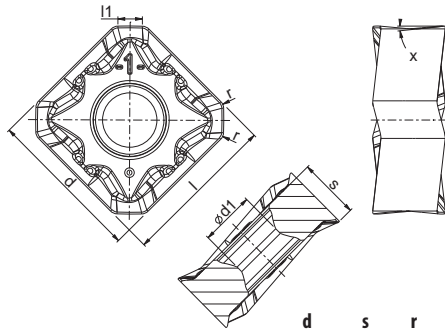

P	●	●	●	●	○	○	○										
M	○	○	○	○	●	●	●	●								●	
K		○								●	●	●	○				○
N													●				
S															●	●	
H																	●

Art. / Арт.	d (mm)	s (mm)	r (mm)	d1 (mm)	l1 (mm)	X (°)	P3530M	P30D	P35M	P35W	M135	M3540P	M40P	M135GP	K115	HK115	K120	N15K	SM35	ST35	H15K	
SOKU 1205AZER MR	13	5.0	0.8	4.55	2	6		●	●	●												
SOKU 1205AZER M-AF	13	5.0	0.8	4.55	2	6							●						●			
SOKU 1505AZER MR	15.875	6.0	1.0	5.74	2.7	6		●	●	●												
SOKU 1505AZER M-AF	15.875	6.0	1.0	5.74	2.7	6							●						●			
SOKU 1505AZER SCE	15.875	6.0	1.0	5.74	2.7	6										●	●					

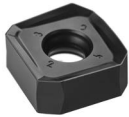

Material
Обрабатываемые материалы

		HB	P3530M	P30D	P35M	P35W	M135	M3540P	M40P	M135GP	K115	HK115	K120	N15K	SM35	ST35	H15K
P	Not alloy steel - Нелегированная сталь	125-300		220-85	220-80	220-80			200-60							180-75	
	Low alloy steel - Низколегированная сталь	180-350		185-70	185-60	185-60			150-60							140-60	
	Alloy steel - Легированная сталь	200-325		150-60	140-60	140-60			140-60							140-60	
	Stainless steel mart - Мартенситная нерж. сталь	200-240		140-60	130-60	130-60			160-60							150-60	
M	Stainless steel aust - Аустенитная нерж. сталь	180-230		120-60	120-60	120-60			140-60						150-60		
K	Cast iron- Чугун											320-100	280-80				
S	Hig. temp. alloy - Жаропрочные сплавы	200-320														50-40	
	Titanium - Титановые сплавы	400-1050														50-40	

SOKU12 **SOKU15**

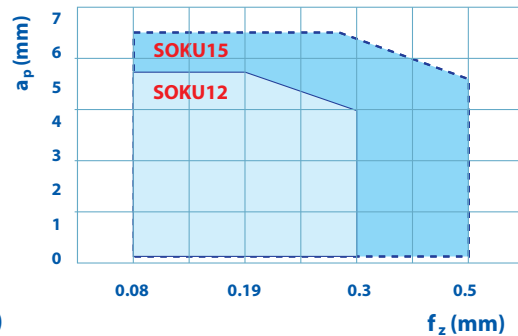
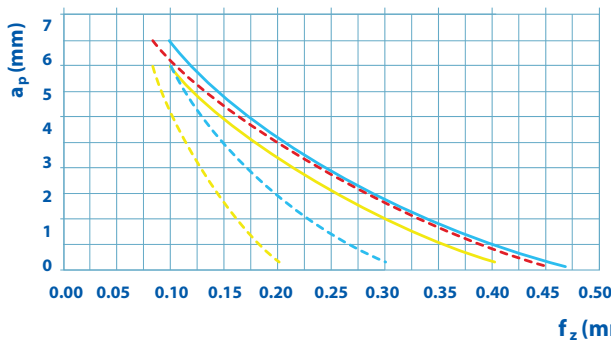

Chipbreaker

Описание стружколомов



MR
Strong cutting edge for general steel applications and hard conditions milling.
Усиленная режущая кромка для обработки всех видов сталей. Подходит для фрезерования в тяжелых условиях.



M-AF
Sharp cutting edge for general stainless steel applications and for finishing in steels.
Острая режущая кромка для полустойковой обработки нержавеющей стали. Чистовая обработка стали.

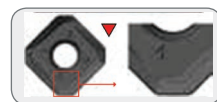

SCE
Strong cutting edge for cast iron applications.
Усиленная режущая кромка для обработки чугунов.

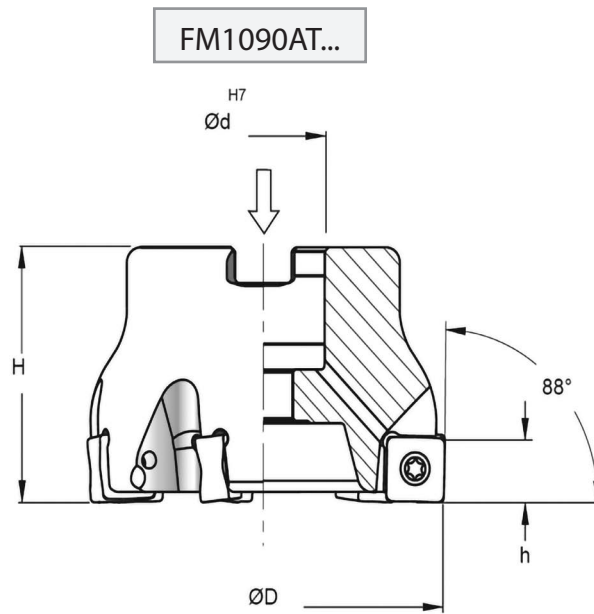

- On request / по запросу
- In stock / в наличии

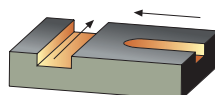

Art. / Apr.	ØD (mm)	Ød (mm)	H (mm)	h (mm)	Z (mm)	kg	Nm				
FM1090AT.50.22.4	50	22	40	11,5	4	0,27	3,8÷5				
FM1090AT.63.22.6	63	22	40	11,5	6	0,46	3,8÷5				
FM1090AT.80.27.7	80	27	50	11,5	7	0,94	3,8÷5				
FM1090AT.80.27.9	80	27	50	11,5	9	0,92	3,8÷5				
FM1090AT.100.32.8	100	32	50	11,5	8	1,63	3,8÷5				
FM1090AT.100.32.11	100	32	50	11,5	11	1,59	3,8÷5				
FM1090AT.125.40.10	125	40	63	11,5	10	3,05	3,8÷5				
FM1090AT.125.40.14	125	40	63	11,5	14	2,99	3,8÷5				
FM1090AT.160.40.12	160	40	63	11,5	12	4,00	3,8÷5				
FM1090AT.160.40.18	160	40	63	11,5	18	3,91	3,8÷5				
FM1090AT.200.60.14	200	60	63	11,5	14	6,61	3,8÷5				
FM1090AT.200.60.22	200	60	63	11,5	22	6,48	3,8÷5				
FM1090AT.250.60.16	250	60	63	11,5	16	9,68	3,8÷5				
FM1090AT.250.60.24	250	60	63	11,5	24	9,52	3,8÷5				

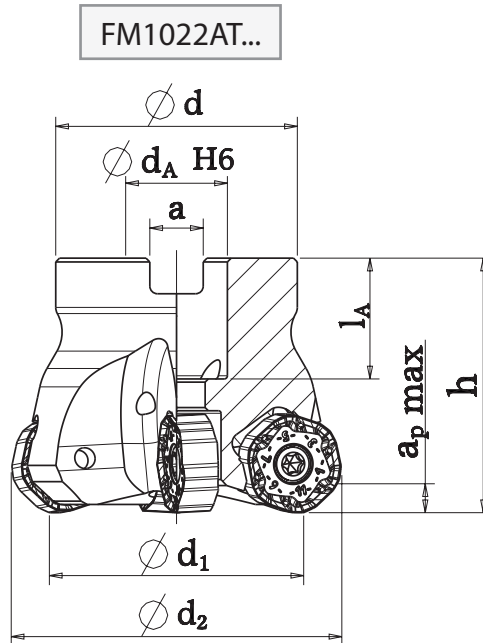



Art. / Apr.	$\varnothing d_1$ (mm)	$\varnothing d_2$ (mm)	h (mm)	d (mm)	dA (mm)	a (mm)	z		
FM1022AT.040.14.16.4	40	52	40	38	16	4.5	4	HNKU 08	1345432
FM1022AT.050.14.22.4	50	62	40	43	22		4	HNKU 08	1345432
FM1022AT.063.14.22.5	63	75	40	48	22		5	HNKU 08	1345432
FM1022AT.080.14.27.6	80	92	50	58	27		6	HNKU 08	1345432
FM1022AT.100.14.32.8	100	102	50	78	32		8	HNKU 08	1345432
FM1022AT.125.14.40.9	125	137	63	88	40		9	HNKU 08	1345432

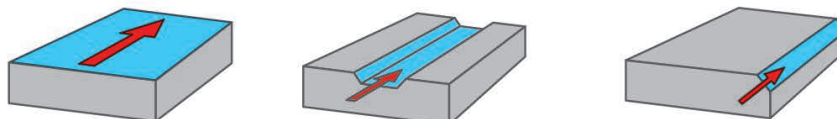

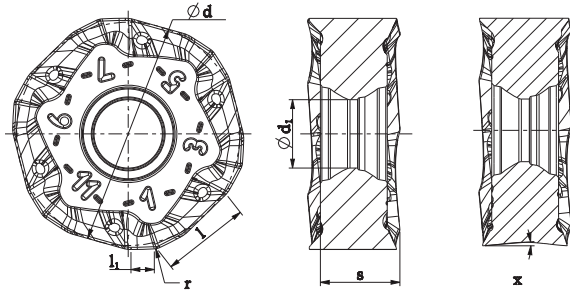

P	●	●	●	●	○	○	○											
M	○	○	○	○	●	●	●										●	
K		○								●	●	●	○					○
N																●		
S																	●	●
H																		●

Art. / Apr.	d (mm)	l (mm)	s (mm)	r (mm)	d1 (mm)	l1 (mm)	X (°)	P3530M	P30D	P35M	P35W	M135	M3540P	M40P	M135GP	K115	HK115	K120	N15K	SM35	S135	H15K	
HNKU 0806AZER MR	14,7	7.5	5.19	1.0	4.5	1.5	-		●		●												
HNKU 0806AZER M-AF	14,7	7.5	5.19	1.0	4.5	1.5	-							○							●		
HOKU 0806AZER MR	14,7	7.5	5.23	1.0	4.5	1.5	4.5		●		●												
HOKU 0806AZER M-AF	14,7	7.5	5.23	1.0	4.5	1.5	4.5							●							●		



Material
Обрабатываемые материалы

		HB	P3530M	P30D	P35M	P35W	M135	M3540P	M40P	M135GP	K115	HK115	K120	N15K	SM35	S135	H15K		
P	Not alloy steel - Нелегированная сталь	125-300		220-85		220-80												180-75	
	Low alloy steel - Низколегированная сталь	180-350		185-70		185-60												140-60	
	Alloy steel - Легированная сталь	200-325		150-60		140-60												140-60	
	Stainless steel mart - Мартенситная нерж. сталь	200-240		140-60		130-60												150-60	
M	Stainless steel aust - Аустенитная нерж. сталь	180-230		120-60		120-60			200-60									150-60	
S	Hig. temp. alloy - Жаропрочные сплавы	200-320																50-40	
	Titanium - Титановые сплавы	400-1050																50-40	

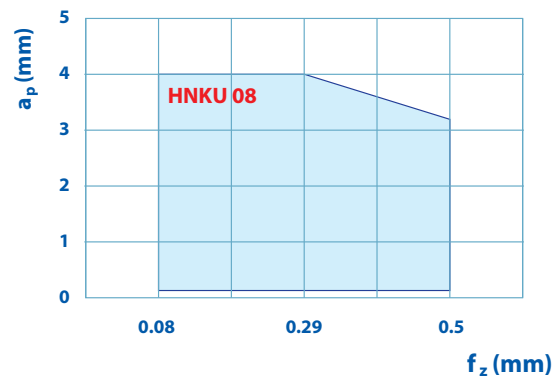
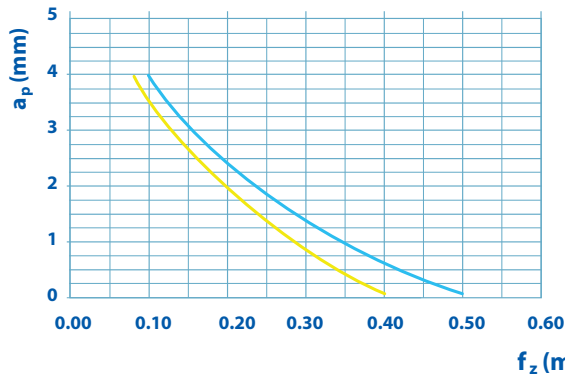

Chipbreaker
Описание стружколомов



MR
Strong cutting edge for general steel applications and hard conditions milling.
Усиленная режущая кромка для обработки всех видов сталей. Подходит для фрезерования в тяжелых условиях.



M-AF
Sharp cutting edge for general stainless steel applications and for finishing in steels.
Острая режущая кромка для полустойкой обработки нержавеющей стали. Чистовая обработка стали.

- On request / по запросу
- In stock / в наличии

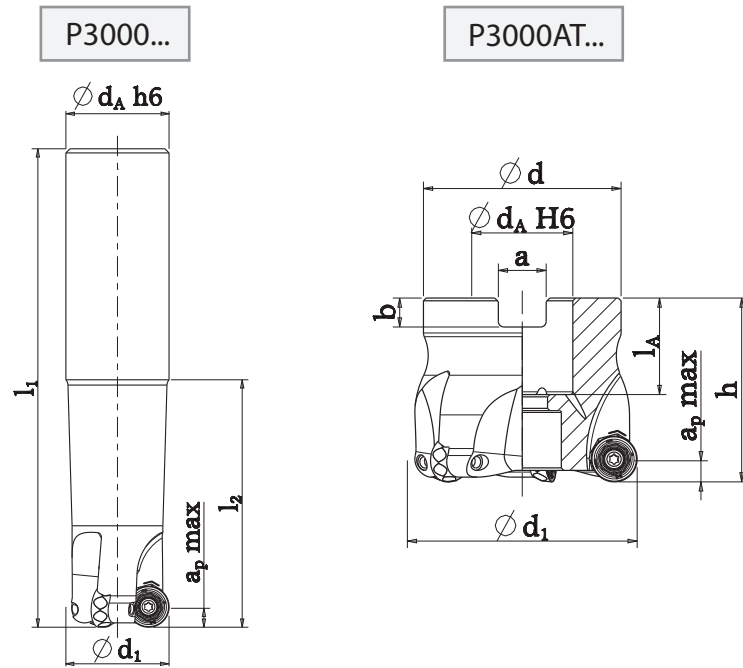

Art. / Apr.	$\varnothing D$ (mm)	l_1 (mm)	l_2 (mm)	h (mm)	d (mm)	d_A (mm)	a (mm)	z		
P3000.020.10.50.100.2	20	102	50	-	-	20		2	RP/RD...10	11689894
P3000.020.10.50.165.2	20	165	50	-	-	20		2	RP/RD...10	11689894
P3000.025.10.60.116.3	25	116	60	-	-	25		3	RP/RD...10	11689894
P3000.025.10.60.165.3	25	165	60	-	-	25		3	RP/RD...10	11689894
P3000.032.10.70.130.4	32	130	70	-	-	32		4	RP/RD...10	11689894
P3000.032.10.70.165.4	32	165	70	-	-	32		4	RP/RD...10	11689894
P3000AT.040.10.16.4	40	-	-	40	38	16		4	RP/RD...10	11689894
P3000AT.042.10.16.5	42	-	-	40	38	16		5	RP/RD...10	11689894
P3000AT.050.10.22.5	50	-	-	40	43	22		5	RP/RD...10	11689894

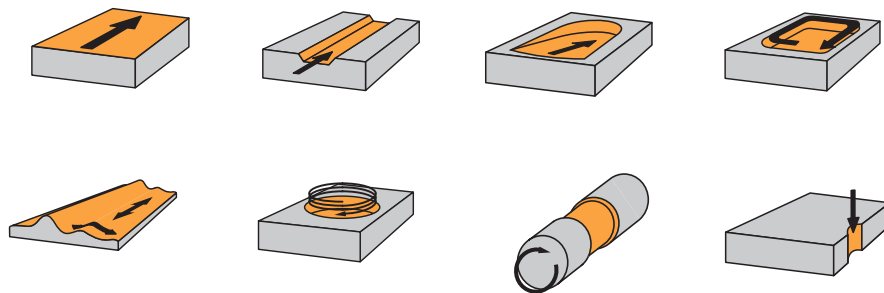

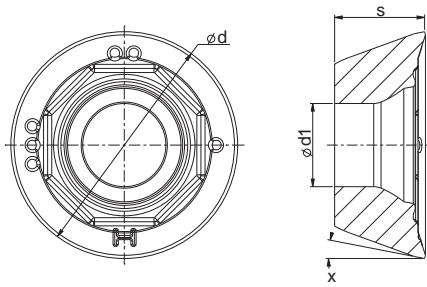

P	●	●	●	●	○	○	○										
M	○	○	○	○	●	●	●	●								●	
K		○							●	●	●	○					○
N															●		
S																●	●
H																	●

Art. / Apr.	d (mm)	s (mm)	r (mm)	d1 (mm)	l1 (mm)	X (°)	P3530M	P30D	P35M	P35W	M135	M3540P	M40P	M135GP	K115	HK115	K120	N15K	SM35	S135	H15K	
RPMX 10T3MO MR	10	3.97	-	3.4	-	11		●		●												
RPMX 10T3MO M-AF	10	3.97	-	3.4	-	11							●							●		
RDHX 10T3MO M-F	10	3.97	-	3.4	-	15												●				
RPHX 10T3MO MS	10	3.97	-	3.4	-	11														●	●	
RDHW 10T3MO MS-S	10	3.97	-	3.4	-	15																●



Material
Обрабатываемые материалы

Material	Обрабатываемые материалы	HB																				
			P3530M	P30D	P35M	P35W	M135	M3540P	M40P	M135GP	K115	HK115	K120	N15K	SM35	S135	H15K					
P	Not alloy steel - Нелегированная сталь	125-300		220-85		220-80				200-60										180-75		
	Low alloy steel - Низколегированная сталь	180-350		185-70		185-60			150-60											140-60		
	Alloy steel - Легированная сталь	200-325		150-60		140-60			140-60											140-60		
	Stainless steel mart - Мартенситная нерж. сталь	200-240		140-60		130-60			160-60											150-60		
M	Stainless steel aust - Аустенитная нерж. сталь	180-230		120-60		120-60			140-60											150-60		
N	Aluminium - Алюминиевые сплавы	60-130																		<2000		
	Hig. temp. alloy - Жаропрочные сплавы	200-320																		50-40	75-25	
S	Titanium - Титановые сплавы	400-1050																		50-40	75-25	
	Hardened materials - Закаленные стали	65-60																				180-100

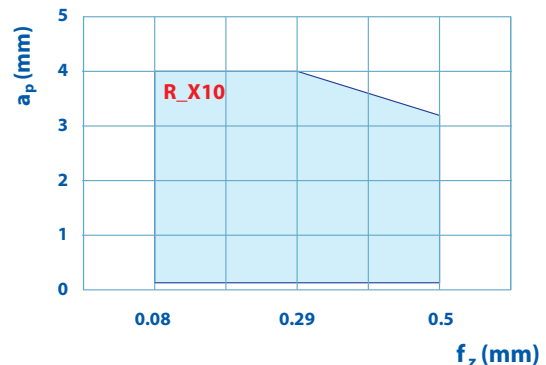
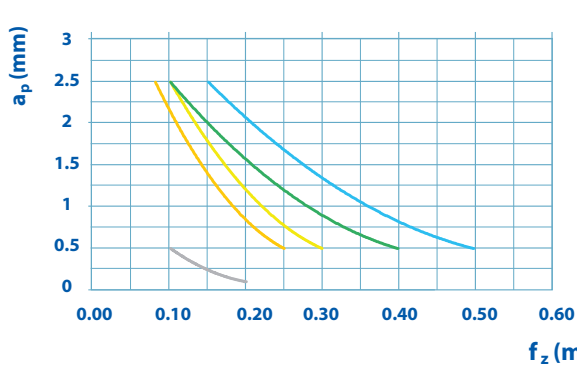

Chipbreaker

Описание стружколомов

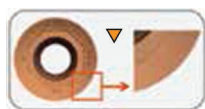

MS
Stable cutting edge for dedicated exotic materials and titanium.
Получистовая обработка жаропрочных сплавов и титана.



M-AF
Sharp cutting edge for general stainless steel applications and for finishing in steels.
Острая режущая кромка для получистовой обработки нержавеющей стали. Чистовая обработка стали.



M-F
Sharp cutting edge for aluminium and nonferrous metal.
Острая режущая кромка для обработки алюминия и неметаллов.



MS-S
Strong reinforced cutting edge for hard material.
Усиленная режущая кромка для обработки труднообрабатываемых материалов.



MR
Strong cutting edge for general steel applications and hard conditions milling.
Усиленная режущая кромка для обработки всех видов сталей. Подходит для фрезерования в тяжелых условиях.

- On request / по запросу
- In stock / в наличии

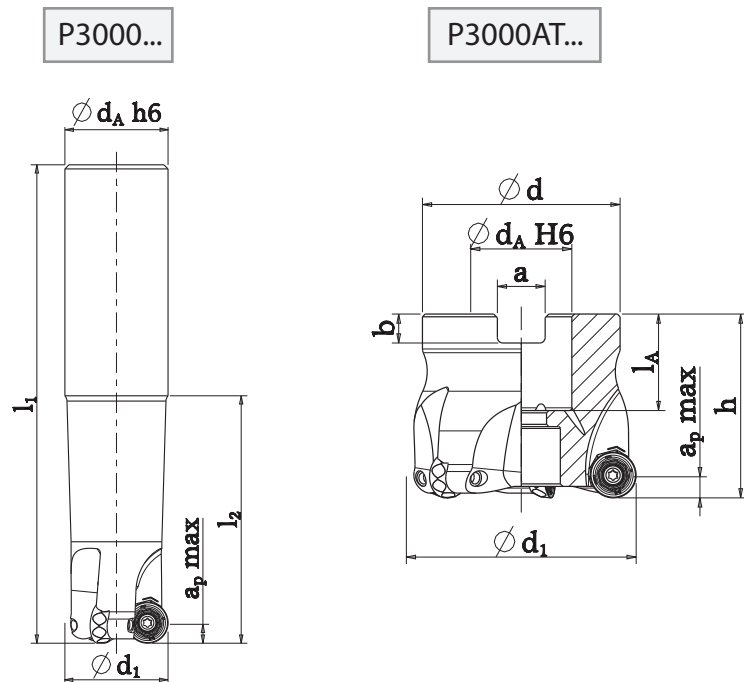

Art. / Apr.	$\varnothing d_1$ (mm)	h_1 (mm)	l_2 (mm)	h (mm)	d (mm)	d_A (mm)	a (mm)	z		
P3000.025.12.30.086.2	25	86	30	-	-	25		2	RP/RD...12	11037484
P3000.025.12.60.116.2	25	116	60	-	-	25		2	RP/RD...12	11037484
P3000.032.12.40.100.3	32	100	40	-	-	32		3	RP/RD...12	11037484
P3000.032.12.70.130.3	32	130	70	-	-	32		3	RP/RD...12	11037484
P3000AT.040.12.16.4	40	-	-	40	38	16		4	RP/RD...12	11036880
P3000AT.042.12.16.4	42	-	-	40	38	16		4	RP/RD...12	1345432
P3000AT.050.12.22.5	50	-	-	40	43	22	6	5	RP/RD...12	1345432
P3000AT.052.12.22.5	52	-	-	40	43	22	6	5	RP/RD...12	1345432
P3000AT.063.12.22.6	63	-	-	40	48	22	6	6	RP/RD...12	1345432
P3000AT.066.12.22.6	66	-	-	40	58	27	6	6	RP/RD...12	1345432
P3000AT.080.12.27.8	80	-	-	50	58	27	6	8	RP/RD...12	1345432
P3000AT.100.12.32.10	100	-	-	50	78	32	6	10	RP/RD...12	1345432

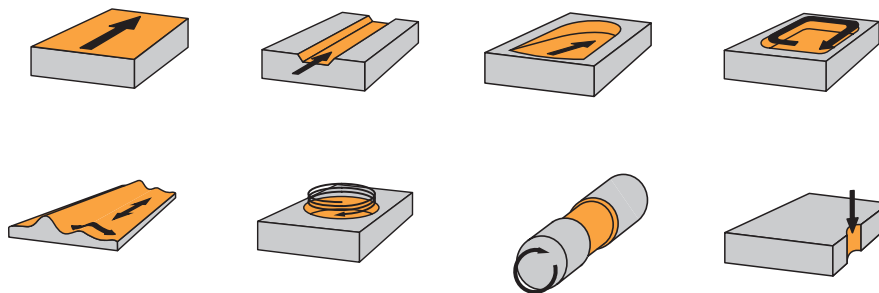

* when using insert RPMX 1204MO FMR or RPMX 1204MO FM-AF diameter of the working parts reduced to 0.25mm; the length of the cutting portions will decrease by 0.13mm.



при использовании пластин RPMX 1204MO FMR и RPMX 1204MO FM-AF диаметр рабочей части уменьшится на 0,25мм; длина режущей части уменьшится на 0,13мм.

**when using insert EOMT 120416 MR or EOMT 120416 M-AF diameter of the working parts reduced to 0.25mm; the length of the cutting portions will decrease by 0.13mm.

при использовании пластин EOMT 120416 MR и EOMT 120416 M-AF диаметр рабочей части уменьшится на 0,25мм; длина режущей части уменьшится на 0,13мм.

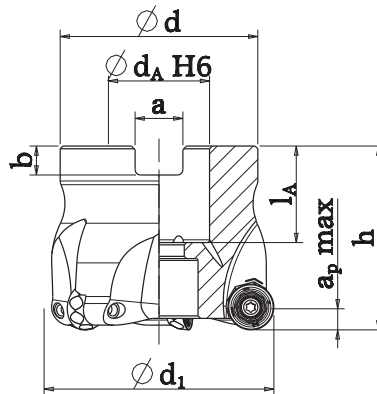
P3000AT...



Art. / Apr.	$\varnothing d_1$ (mm)	h (mm)	d (mm)	dA (mm)	a (mm)	z		
P3000AT.050.16.22.3	50	40	48	22	8	3	RP/SD...X	1345431
P3000AT.052.16.22.4	52	40	48	22		4	RP/SD...X	1345431
P3000AT.063.16.22.5	63	40	48	22		5	RP/SD...X	1345431
P3000AT.066.16.22.5	63	40	48	22		5	RP/SD...X	1345431
P3000AT.080.16.27.6	80	50	58	27		6	RP/SD...X	1345431
P3000AT.100.16.32.7	100	50	78	32		7	RP/SD...X	1345431
P3000AT.125.16.40.8	125	63	88	40		8	RP/SD...X	1345431

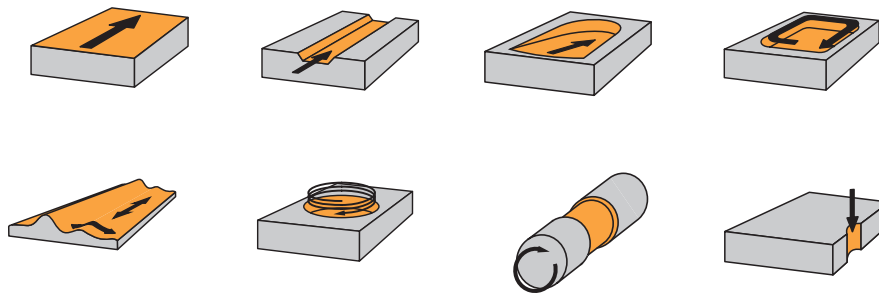

* when using insert RPMX 1605MO FMR or RPMX 1605MO FM-AF diameter of the working parts reduced to 0.2mm; the length of the cutting portions will decrease by 0.1mm.

при использовании пластин RPMX 1605MO FMR и RPMX 1605MO FM-AF диаметр рабочей части уменьшится на 0,2мм; длина режущей части уменьшится на 0,1мм.

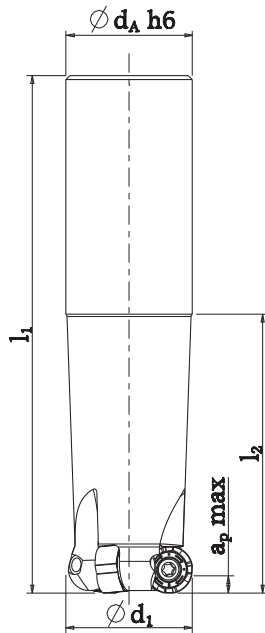
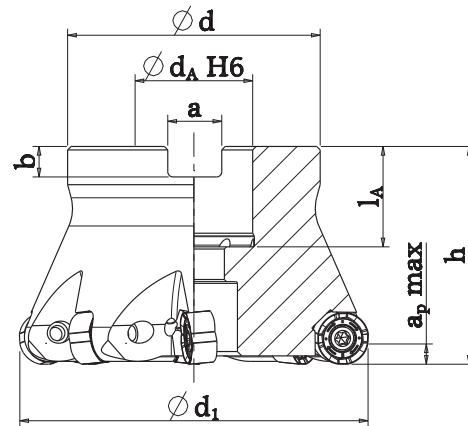
FM1088...

FM1088AT..

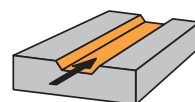
Art. / Apr.	$\varnothing d_1$ (mm)	l_1 (mm)	l_2 (mm)	h (mm)	d (mm)	d_A (mm)	a (mm)	z		
FM1088.032.12.70.131.3	32	131	70	-	-	32		3	RN/RO..12	11037484
FM1088.032.12.70.165.3	32	165	70	-	-	32		3	RN/RO..12	11037484
FM1088AT.040.12.16.4	40	-	-	40	38	16		4	RN/RO..12	1345432
FM1088AT.050.12.22.5	50	-	-	40	43	22	4.5	5	RN/RO..12	1345432
FM1088AT.063.12.22.6	63	-	-	40	48	22		6	RN/RO..12	1345432
FM1088AT.080.12.27.8	80	-	-	50	58	27		8	RN/RO..12	1345432
FM1088AT.100.12.32.10	100	-	-	50	78	32		10	RN/RO..12	1345432
FM1088AT.050.16.22.3*	50	-	-	40	43	22		3	RN/RO..16	188399
FM1088AT.063.16.22.5	63	-	-	40	48	22		5	RN/RO..16	188399
FM1088AT.080.16.27.6*	80	-	-	50	58	27	6	6	RN/RO..16	188399
FM1088AT.100.16.32.7*	100	-	-	50	78	32		7	RN/RO..16	188399
FM1088AT.125.16.40.8*	125	-	-	63	88	40		8	RN/RO..16	188399

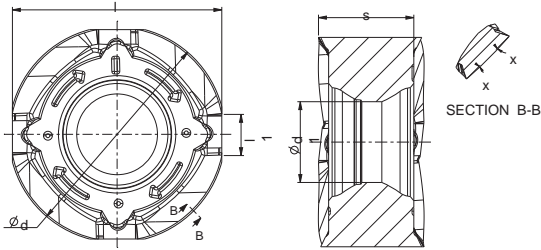

* On request / по запросу



P	●	●	●	●	○	○	○										
M	○	○	○	○	●	●	●									●	
K		○								●	●	●	○				○
N															●		
S																●	●
H																	●



Art. / Apr.	d (mm)	s (mm)	l (mm)	d1 (mm)	l1 (mm)	X (°)	P3530M	P30D	P35M	P35W	M135	M3540P	M40P	M135GP	K115	HK115	K120	N15K	SM35	S135	H15K	
RNKH 1204MOER MR	12	5.9	11.8	4.5	2.3	0		●		●												
ROHU 1204MOER M-AF	12	5.9	11.8	4.5	2.3	3							●							●		
RNKH 1605MOER MR	16	6.7	15.7	5.8	2.7	0		●		●												
ROHU 1605MOER M-AF	16	6.7	15.7	5.8	2.7	3							●							●		

Material
Обработываемые материалы

	HB	P3530M	P30D	P35M	P35W	M135	M3540P	M40P	M135GP	K115	HK115	K120	N15K	SM35	S135	H15K
P Not alloy steel - Нелегированная сталь	125-300		220-85		220-80			200-60								180-75
Low alloy steel - Низколегированная сталь	180-350		185-70		185-60			150-60								140-60
Alloy steel - Легированная сталь	200-325		150-60		140-60			140-60								140-60
Stainless steel mart - Мартенситная нерж. сталь	200-240		140-60		130-60			160-60								150-60
M Stainless steel aust - Аустенитная нерж. сталь	180-230		120-60		120-60			140-60								150-60
S Hig. temp. alloy - Жаропрочные сплавы	200-320															50-40
Titanium - Титановые сплавы	400-1050															50-40

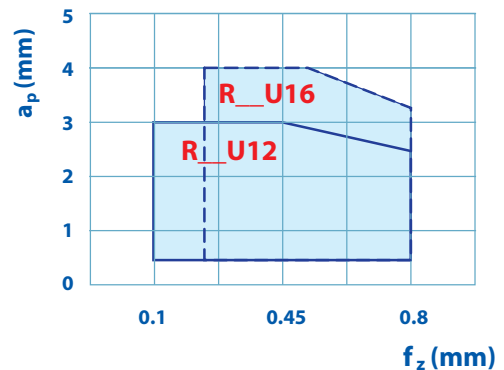
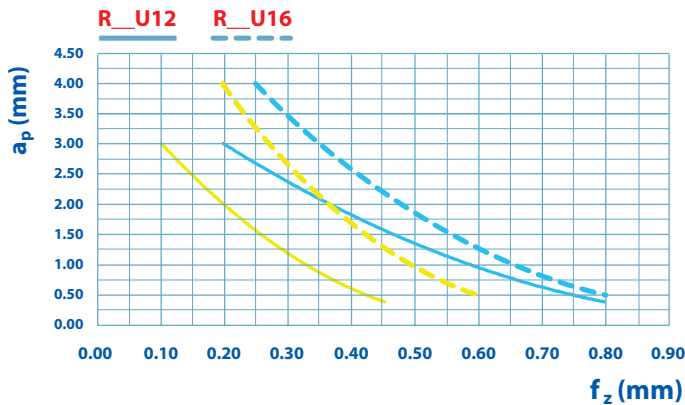

Chipbreaker
Описание стружколомов

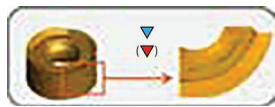



MR
Strong cutting edge for general steel applications and hard conditions milling.
Усиленная режущая кромка для обработки всех видов сталей. Подходит для фрезерования в тяжелых условиях.

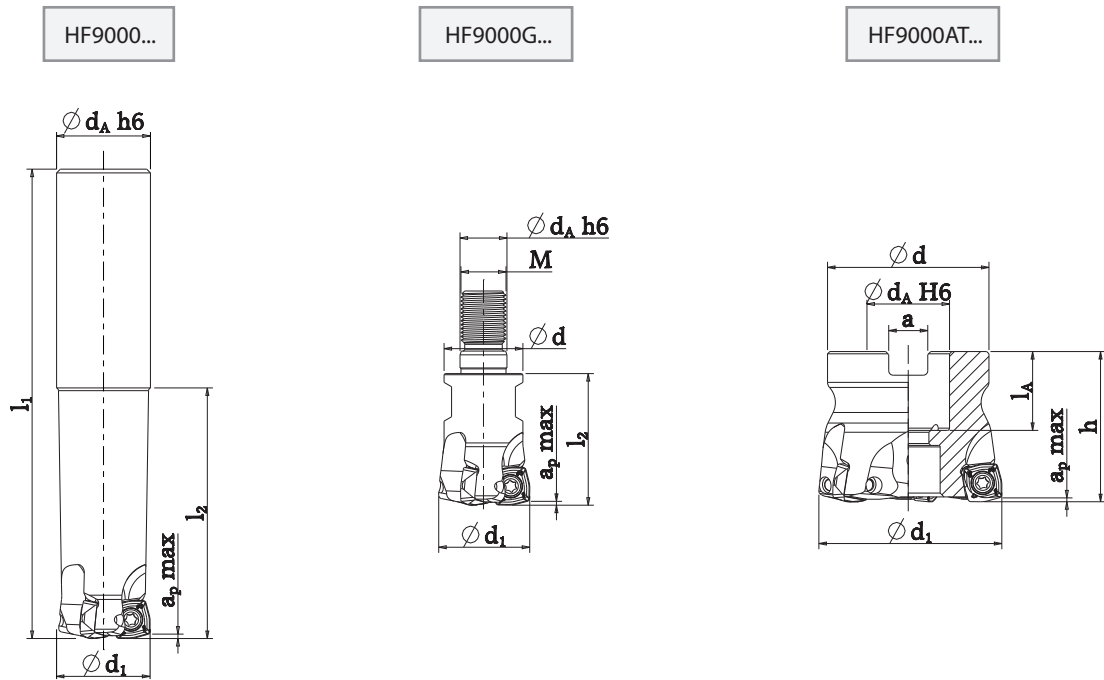

M-AF
Sharp cutting edge for general stainless steel applications and for finishing in steels.
Острая режущая кромка для получистовой обработки нержавеющей стали. Чистовая обработка стали.

- On request / по запросу
- In stock / в наличии



Art. / Apr.	∅ d1 (mm)	l1 (mm)	l2 (mm)	h (mm)	d (mm)	dA (mm)	a (mm)	z		
HF9000.016.07.50.200.2	16	200	50	-	-	16	0.8	2	XPLT 07	76913
HF9000.020.07.50.200.3	20	200	50	-	-	20		3	XPLT 07	76913
HF9000.025.07.50.200.4	25	200	50	-	-	25		4	XPLT 07	76913
HF9000G.016.07.43.2	16	-	-	43	13.8	M8		2	XPLT 07	76913
HF9000G.020.07.49.3	20	-	-	49	18	M10		3	XPLT 07	76913
HF9000G.025.07.57.4	25	-	-	57	21	M12		4	XPLT 07	76913
HF9000.025.10.50.225.3	25	225	50	-	-	25	1	3	XDLT/X 10	54976
HF9000AT.040.10.16.4	40	-	-	40	38	16		4	XDLT/X 10	165795
HF9000AT.050.10.22.5	50	-	-	40	43	22		5	XDLT/X 10	165795
HF9000AT.063.10.22.6	63	-	-	40	48	22		6	XDLT/X 10	165795
HF9000.035.13.63.250.3	35	250	63	-	-	32	2	3	XOLT 13	106022
HF9000AT.050.13.22.4	50	-	-	40	43	22		4	XOLT 13	106022
HF9000AT.063.13.22.5	63	-	-	40	48	22		5	XOLT 13	106022
HF9000AT.080.13.27.7	80	-	-	50	58	27		7	XOLT 13	106022

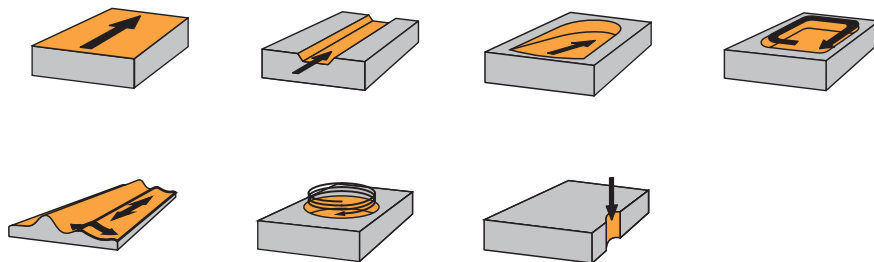

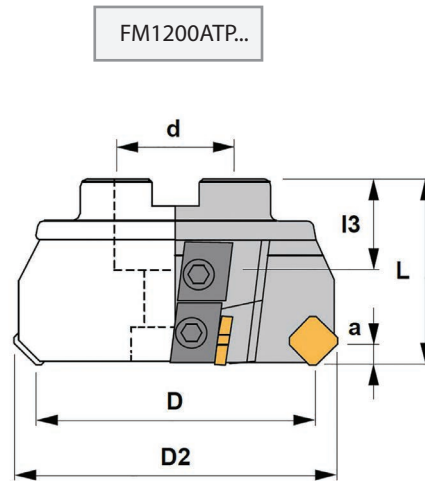
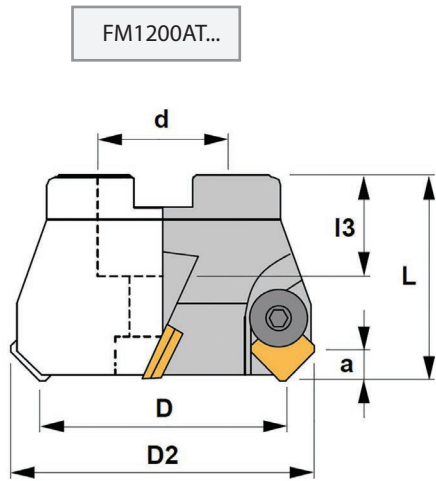

Art. / Apr.	Ø D (mm)	Ø D2 (mm)	l (mm)	l3 (mm)	d (mm)	a (mm)	z							
FM1200AT.050.12.22.4	50	63	40	20	22	6	4	SEK.. 1203..	1006L	2063	3010	4016	5004	912,10
FM1200AT.063.12.22.5	63	76	50	20	22	6	5	SEK.. 1203..	1006L	2063	3010	4016	5004	912,10
FM1200AT.080.12.27.6	80	93	50	22	27	6	6	SEK.. 1203..	1006L	2063	3010	4016	5004	912,12
FM1200AT.100.12.32.6	100	113	50	25	32	6	6	SEK.. 1203..	1006L	2063	3010	4016	5004	912,17
FM1200AT.125.12.40.7	125	138	63	30	40	6	7	SEK.. 1203..	1006L	2063	3010	4016	5004	-
FM1200AT.160.12.40.8	160	173	63	30	40	6	8	SEK.. 1203..	1006L	2063	3010	4016	5004	912,52
FM1200AT.200.12.60.10	200	213	63	40	60	6	10	SEK.. 1203..	1006L	2063	3010	4016	5004	912,56

Art. / Apr.	Ø D (mm)	Ø D2 (mm)	l (mm)	l3 (mm)	d (mm)	a (mm)	z								
FM1200ATP.080.12.27.6	80	92	50	22	27	6	6	SEK.. 1203..	1077	912,12	-	-	-	-	1460
FM1200ATP.100.12.32.8	100	112	50	25	32	6	8	SEK.. 1203..	1077	912,17	-	-	-	-	1460
FM1200ATP.125.12.40.8	125	137	63	30	40	6	8	SEK.. 1203..	1077	-	-	-	-	-	1460
FM1200ATP.160.12.40.10	160	172	63	30	40	6	10	SEK.. 1203..	1077	912,52	-	-	-	-	1460
FM1200ATP.200.12.60.12	200	212	63	40	60	6	12	SEK.. 1203..	1077	912,56	-	-	-	-	1460
FM1200ATP.250.12.60.16	250	262	63	40	60	6	16	SEK.. 1203..	1077	912,56	-	-	-	-	1460
FM1200ATP.080.15.27.6	80	98	50	22	27	9	6	SEK.. 1504..	1077	912,12	5520	6488	6489	6918	1460
FM1200ATP.100.15.32.8	100	118	50	25	32	9	8	SEK.. 1504..	1077	912,17	5620	6488	6489	6918	1460
FM1200ATP.125.15.40.8	125	143	63	30	40	9	8	SEK.. 1504..	1077	-	5620	6488	6489	6918	1460
FM1200ATP.160.15.40.10	160	178	63	30	40	9	10	SEK.. 1504..	1077	912,52	5620	6488	6489	6918	1460
FM1200ATP.200.15.60.12	200	218	63	40	60	9	12	SEK.. 1504..	1077	912,56	5620	6488	6489	6918	1460
FM1200ATP.250.15.60.16	250	268	63	40	60	9	16	SEK.. 1504..	1077	912,56	5620	6488	6489	6918	1460

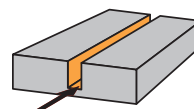
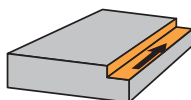

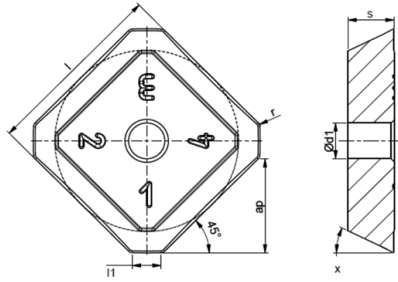

P	●	●	●	●	○	○	○										
M	○	○	○	○	●	●	●										
K		○									●	●	●	○			○
N														●			
S															●	●	
H																	●



Art. / Apr.	l (mm)	s (mm)	ap (mm)	l1 (mm)	r (mm)	d1 (mm)	X (°)	P3530M	P30D	P35W	P35M	M135	M3540P	M40P	M135GP	K115	HK115	K120	N15K	SM35	ST35	H15K	
SEKN 1203AFSN MR	12.7	3.18	6.3	2	0.45	2.5	25	●	●		●					●							
SEKR 1203AFSN M-AF	12.7	3.18	6.4	2	0.45	2.5	25	●					●	●							○		
SEKR 1504AFSN M-AF	15.875	4.72	8.5	1.7	1	2.5	25	●					●	●							○		

Material
Обрабатываемые материалы

	HB	P3530M	P30D	P35W	P35M	M135	M3540P	M40P	M135GP	K115	HK115	K120	N15K	SM35	ST35	H15K
P Not alloy steel - Нелегированная сталь	125-300	220-85	220-85		220-85		200-60								180-75	
Low alloy steel - Низколегированная сталь	180-350	185-70	185-70		185-70		150-60	140-60							140-60	
Alloy steel - Легированная сталь	200-325	150-60	150-60		150-60		140-60	130-60							140-60	
Stainless steel mart - Мартенситная нерж. сталь	200-240	140-60	140-60		140-60		160-60	150-60							150-60	
M Stainless steel aust - Аустенитная нерж. сталь	180-230	120-60					150-60	135-60							150-60	
K Cast iron - Чугун										320-100						
S Hig. temp. alloy - Жаропрочные сплавы	200-320														50-40	
Titanium - Титановые сплавы	400-1050														50-40	

SEK_12 SEK_15

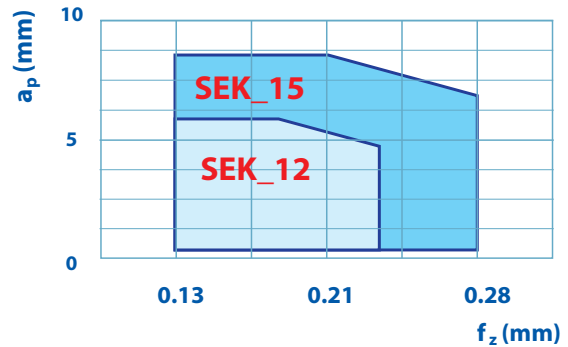
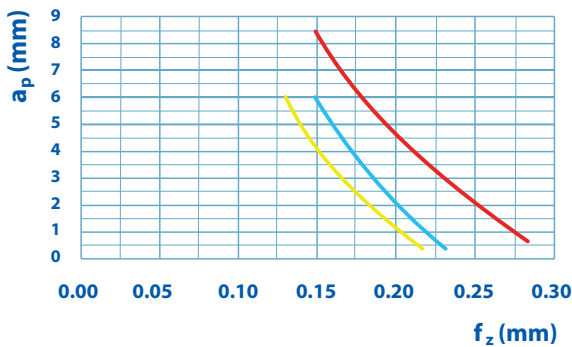

Chipbreaker
Описание стружколомов

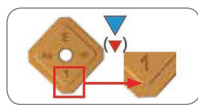

MR
Strong cutting edge for general steel applications and hard conditions milling.
Усиленная режущая кромка для обработки всех видов сталей. Подходит для фрезерования в тяжелых условиях.

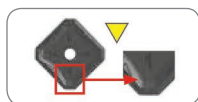

M-AF
Sharp cutting edge for general stainless steel applications and for finishing in steels.
Острая режущая кромка для получистовой обработки нержавеющей стали. Чистовая обработка стали.

- On request / по запросу
- In stock / в наличии

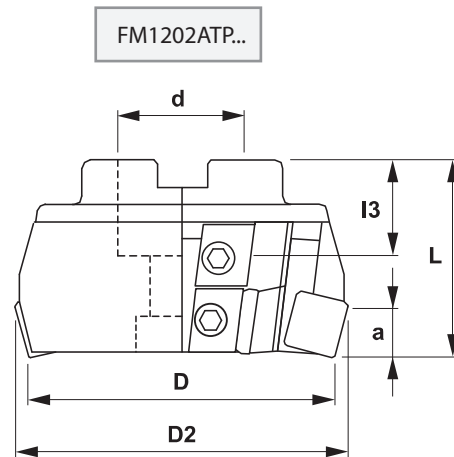
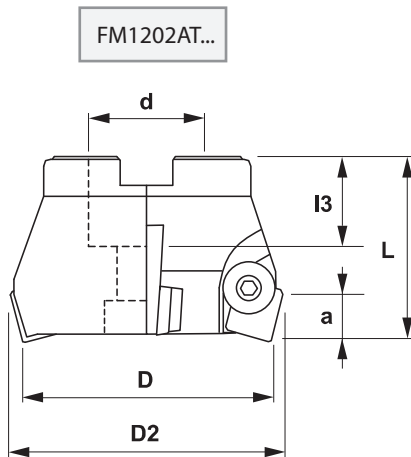

Art. / Apr.	Ø D (mm)	Ø D2 (mm)	l (mm)	l3 (mm)	d (mm)	a (mm)	z						
FM1202AT.040.12.16.3	40	46	40	18	16	9	3	SP. 1203..	1006	2066	-	-	1058
FM1202AT.050.12.22.3	50	56	40	20	22		3	SP. 1203..	1006	2066	3012	4012	912.10
FM1202AT.063.12.27.4	63	69	50	22	27		4	SP. 1203..	1006	2066	3012	4012	912.12
FM1202AT.080.12.32.5	80	86	50	25	32		5	SP. 1203..	1006	2066	3012	4012	912.17
FM1202AT.100.12.40.6	100	106	50	30	40		6	SP. 1203..	1006	2066	3012	4012	912.20
FM1202AT.125.12.40.6	125	131	63	30	40		6	SP. 1203..	1006	2066	3012	4012	-
FM1202AT.160.12.40.7	160	166	63	30	40		7	SP. 1203..	1006	2066	3012	4012	912.52
FM1202AT.200.12.60.8	200	206	63	40	60		8	SP. 1203..	1006	2066	3012	4012	912.56

Art. / Apr.	Ø D (mm)	Ø D2 (mm)	l (mm)	l3 (mm)	d (mm)	a (mm)	z							
FM1202ATP.080.12.27.5	80	86	50	22	27	9	5	SP. 1203..	1077	6437	6438	6914	912.12	1460
FM1202ATP.100.12.32.7	100	106	50	25	32		7	SP. 1203..	1077	6437	6438	6914	912.20	1460
FM1202ATP.125.12.40.8	125	131	63	30	40		8	SP. 1203..	1077	6437	6438	6914	-	1460
FM1202ATP.160.12.40.10	160	166	63	30	40		10	SP. 1203..	1077	6437	6438	6914	912.52	1460
FM1202ATP.200.12.60.12	200	206	63	40	60		12	SP. 1203..	1077	6437	6438	6914	912.56	1460
FM1202ATP.250.12.60.16	250	256	63	40	60		16	SP. 1203..	1077	6437	6438	6914	912.52	1460
FM1202ATP.315.12.60.20	315	321	63	40	60		20	SP. 1203..	1077	6437	6438	6914	912.56	1460
FM1202ATP.400.12.60.26	400	406	63	40	60		26	SP. 1203..	1077	6437	6438	6914	912.52	1460
FM1202ATP.500.12.60.34	500	506	63	40	60	34	SP. 1203..	1077	6437	6438	6914	912.56	1460	

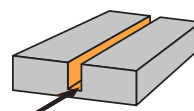
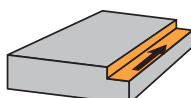

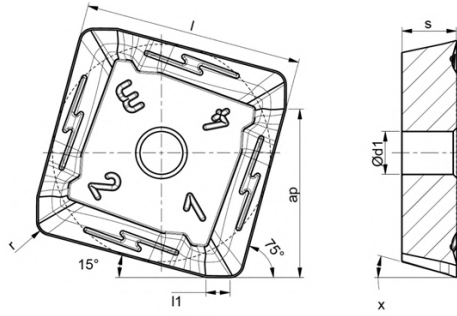

P	●	●	●	●	○	○	○										
M	○	○	○	○	●	●	●	●								●	
K		○							●	●	●	○					○
N													●				
S															●	●	
H																	●



Art. / Арт.	l (mm)	s (mm)	ap (mm)	l1 (mm)	r (mm)	d1 (mm)	X (°)	P3530M	P30D	P35W	P35M	M135	M3540P	M40P	M135GP	K115	HK115	K120	N15K	SM35	S135	H15K	
SPKN 1203EDTR MR	12.7	3.18	9.8	1.2	0.5	2.5	15		●		●					●							
SPKR 1203EDER M-AF	12.7	3.18	9.8	1.4	0.9	2.5	15							●							○		

Material
Обрабатываемые материалы

	HB	P3530M	P30D	P35W	P35M	M135	M3540P	M40P	M135GP	K115	HK115	K120	N15K	SM35	S135	H15K	
P Not alloy steel - Нелегированная сталь	125-300		220-85		220-85			200-60								180-75	
Low alloy steel - Низколегированная сталь	180-350		185-70		185-70			150-60								140-60	
Alloy steel - Легированная сталь	200-325		150-60		150-60			140-60								140-60	
Stainless steel mart - Мартенситная нерж. сталь	200-240		140-60		140-60			160-60								150-60	
M Stainless steel aust - Аустенитная нерж. сталь	180-230		120-60		120-60			140-60								150-60	
K Cast iron- Чугун										320-100							
S Hig. temp. alloy - Жаропрочные сплавы	200-320															50-40	
Titanium - Титановые сплавы	400-1050															50-40	

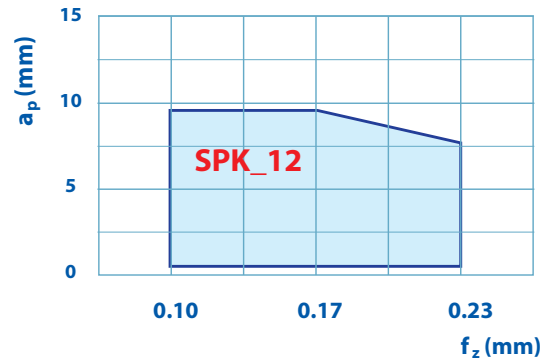
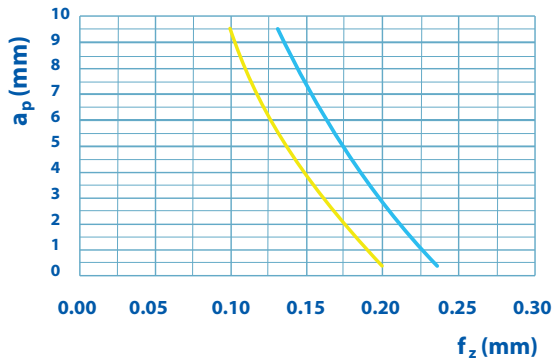

Chipbreaker
Описание стружколомов

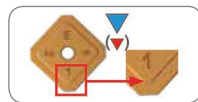

MR
Strong cutting edge for general steel applications and hard conditions milling.
Усиленная режущая кромка для обработки всех видов сталей. Подходит для фрезерования в тяжелых условиях.

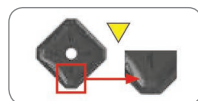

M-AF
Sharp cutting edge for general stainless steel applications and for finishing in steels.
Острая режущая кромка для полуставовой обработки нержавеющей стали. Чистовая обработка стали.

- On request / по запросу
- In stock / в наличии

10

TOOLS WITH CARBIDE INSERTS
ИНСТРУМЕНТ СО СМЕННЫМИ ТВЕРДОСПЛАВНЫМИ ПЛАСТИНАМИ

DRILLS WITH CARBIDE INSERTS
СВЕРЛЕНИЕ СО СМЕННЫМИ ПЛАСТИНАМИ

TABLE OF CONTENTS / СОДЕРЖАНИЕ

SOLID CARBIDE TOOLS		
ТВЕРДОСПЛАВНЫЙ ИНСТРУМЕНТ		3
1	Carbide mills Твердосплавные фрезы	5
2	Carbide drills Твердосплавные сверла	39
3	Special tools Специальные инструменты	49
TOOLS WITH CARBIDE INSERTS		
ИНСТРУМЕНТ СО СМЕННЫМИ ТВЕРДОСПЛАВНЫМИ ПЛАСТИНАМИ		54
4	Turning carbide inserts Токарные твердосплавные пластины	55
5	Toolholders for external turning Токарные державки для наружной обработки	91
6	Toolholders for internal turning Токарные державки для внутренней обработки	123
7	Grooving and parting off Канавка и отрезка	143
8	Threading inserts Резьбонарезные пластины	175
9	Milling with carbide inserts Фрезы со сменными твердосплавными пластинами	217
10	Drills with carbide inserts Сверла со сменными пластинами	271
<input type="checkbox"/>	3D Drilling Сверла 3D	273
<input type="checkbox"/>	4D Drilling Сверла 4D	274
<input type="checkbox"/>	5D Drilling Сверла 5D	275
<input type="checkbox"/>	Inserts for drilling Пластины для сверления	276
<input type="checkbox"/>	Alloy description Описание сплавов	277
<input type="checkbox"/>	Cutting speed for drilling Режимы резания для сверления	278
<input type="checkbox"/>	Inserts for multiturning Пластины для многофункционального сверления	280
<input type="checkbox"/>	Toolholders for multiturning Державки multiturning	282
<input type="checkbox"/>	Alloy description Описание сплавов	283
<input type="checkbox"/>	Cutting speed for multiturning Режимы резания для multiturning	286
<input type="checkbox"/>	Recommendations for use Рекомендации к использованию	290

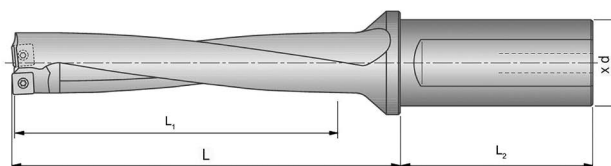
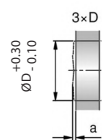

Артикул	D	L	L ₁	L ₂	d	Размеры пластин
DIS 014x3D S05	14	55	42	50	20	SOLT 0502...
DIS 014.5x3D S05	14.5	59	45	50	20	SOLT 0502...
DIS 015x3D S05	15	59	45	50	20	SOLT 0502...
DIS 015.5x3D S05	15.5	64	48	50	20	SOLT 0502...
DIS 016x3D S05	16	64	48	50	20	SOLT 0502...
DIS 016.5x3D S05	16.5	68	51	50	20	SOLT 0502...
DIS 017x3D S06	17	68	51	50	20	SOLT 06T2...
DIS 017.5x3D S06	17.5	71	51	56	25	SOLT 06T2...
DIS 018x3D S06	18	71	54	56	25	SOLT 06T2...
DIS 018.5x3D S06	18.5	75	55.5	56	25	SOLT 06T2...
DIS 019x3D S06	19	75	57	56	25	SOLT 06T2...
DIS 019.5x3D S06	19.5	78	60	56	25	SOLT 06T2...
DIS 020x3D S07	20	78	60	56	20	SOLT 0703...
DIS 020.5x3D S07	20.5	82	61.5	56	25	SOLT 0703...
DIS 021x3D S07	21	85	66	56	25	SOLT 0703...
DIS 021.5x3D S07	21.5	85	66	56	25	SOLT 0703...
DIS 022x3D S07	22	85	66	56	25	SOLT 0703...
DIS 022.5x3D S07	22.5	89	69	56	25	SOLT 0703...
DIS 023x3D S07	23	89	69	56	25	SOLT 0703...
DIS 023.5x3D S08	23.5	92	72	60	32	SOLT 0803...
DIS 024x3D S08	24	92	72	60	32	SOLT 0803...
DIS 024.5x3D S08	24.5	96	75	60	32	SOLT 0803...
DIS 025x3D S08	25	96	78	60	32	SOLT 0803...
DIS 025.5x3D S08	25.5	99	78	60	32	SOLT 0803...
DIS 026x3D S08	26	99	81	60	32	SOLT 0803...
DIS 026.5x3D S08	26.5	103	81	60	32	SOLT 0803...
DIS 027x3D S08	27	103	81	60	32	SOLT 0803...
DIS 027.5x3D S08	27.5	106	84	60	32	SOLT 0803...
DIS 028x3D S08	28	106	84	60	32	SOLT 0803...
DIS 028.5x3D S10	28.5	100	87	60	32	SOLT 10T3...
DIS 029x3D S10	29	110	87	60	32	SOLT 10T3...
DIS 029.5x3D S10	29.5	113	90	60	32	SOLT 10T3...
DIS 030x3D S10	30	113	90	60	32	SOLT 10T3...
DIS 030.5x3D S10	30.5	117	93	68	40	SOLT 10T3...
DIS 031x3D S10	31	117	93	68	40	SOLT 10T3...
DIS 031.5x3D S10	31.5	120	96	68	40	SOLT 10T3...
DIS 032x3D S10	32	120	96	68	40	SOLT 10T3...
DIS 032.5x3D S10	32.5	124	99	68	40	SOLT 10T3...
DIS 033x3D S10	33	124	99	68	40	SOLT 10T3...
DIS 033.5x3D S11	33.5	127	102	68	40	SOLT 1104...
DIS 034x3D S11	34	127	102	68	40	SOLT 1104...
DIS 034.5x3D S11	34.5	131	102	68	40	SOLT 1104...
DIS 035x3D S11	35	131	105	68	40	SOLT 1104...
DIS 035.5x3D S11	35.5	134	105	68	40	SOLT 1104...
DIS 036x3D S11	36	134	108	68	40	SOLT 1104...
DIS 036.5x3D S11	36.5	138	108	68	40	SOLT 1104...
DIS 037x3D S11	37	138	111	68	40	SOLT 1104...
DIS 037.5x3D S11	37.5	141	111	68	40	SOLT 1104...
DIS 038x3D S11	38	141	114	68	40	SOLT 1104...
DIS 038.5x3D S13	38.5	145	117	68	40	SOLT 1305...
DIS 039x3D S13	39	145	117	68	40	SOLT 1305...
DIS 039.5x3D S13	39.5	148	120	68	40	SOLT 1305...
DIS 040x3D S13	40	148	120	68	40	SOLT 1305...
DIS 040.5x3D S13	40.5	152	123	68	40	SOLT 1305...
DIS 041x3D S13	41	152	123	68	40	SOLT 1305...
DIS 041.5x3D S13	41.5	155	126	68	40	SOLT 1305...
DIS 042x3D S13	42	155	126	68	40	SOLT 1305...
DIS 042.5x3D S13	42.5	159	129	68	40	SOLT 1305...
DIS 043x3D S13	43	159	129	68	40	SOLT 1305...
DIS 043.5x3D S13	43.5	162	132	68	40	SOLT 1305...
DIS 044x3D S13	44	162	132	68	40	SOLT 1305...

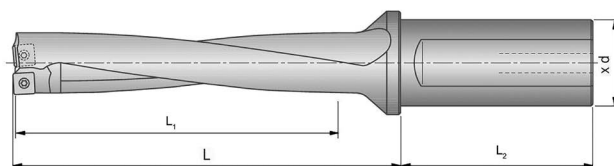
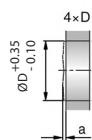

Артикул	D	L	L ₁	L ₂	d	Размеры пластин
DIS 014x4D S05	14	69	56	50	20	SOLT 0502...
DIS 014.5x4D S05	14.5	74	60	50	20	SOLT 0502...
DIS 015x4D S05	15	74	60	50	20	SOLT 0502...
DIS 015.5x4D S05	15.5	80	64	50	20	SOLT 0502...
DIS 016x4D S05	16	80	64	50	20	SOLT 0502...
DIS 016.5x4D S05	16.5	85	68	50	20	SOLT 0502...
DIS 017x4D S06	17	85	68	50	20	SOLT 06T2...
DIS 017.5x4D S06	17.5	89	72	56	25	SOLT 06T2...
DIS 018x4D S06	18	89	72	56	25	SOLT 06T2...
DIS 018.5x4D S06	18.5	94	76	56	25	SOLT 06T2...
DIS 019x4D S06	19	94	76	56	25	SOLT 06T2...
DIS 019.5x4D S06	19.5	98	80	56	25	SOLT 06T2...
DIS 020x4D S07	20	98	80	56	20	SOLT 0703...
DIS 020.5x4D S07	20.5	103	84	56	25	SOLT 0703...
DIS 021x4D S07	21	103	84	56	25	SOLT 0703...
DIS 021.5x4D S07	21.5	107	88	56	25	SOLT 0703...
DIS 022x4D S07	22	107	88	56	25	SOLT 0703...
DIS 022.5x4D S07	22.5	112	92	56	25	SOLT 0703...
DIS 023x4D S07	23	112	92	56	25	SOLT 0703...
DIS 023.5x4D S08	23.5	116	96	60	32	SOLT 0803...
DIS 024x4D S08	24	116	96	60	32	SOLT 0803...
DIS 024.5x4D S08	24.5	121	100	60	32	SOLT 0803...
DIS 025x4D S08	25	121	100	60	32	SOLT 0803...
DIS 025.5x4D S08	25.5	125	104	60	32	SOLT 0803...
DIS 026x4D S08	26	125	104	60	32	SOLT 0803...
DIS 026.5x4D S08	26.5	130	108	60	32	SOLT 0803...
DIS 027x4D S08	27	130	108	60	32	SOLT 0803...
DIS 027.5x4D S08	27.5	134	112	60	32	SOLT 0803...
DIS 028x4D S08	28	134	112	60	32	SOLT 0803...
DIS 028.5x4D S10	28.5	139	116	60	32	SOLT 10T3...
DIS 029x4D S10	29	139	116	60	32	SOLT 10T3...
DIS 029.5x4D S10	29.5	143	120	60	32	SOLT 10T3...
DIS 030x4D S10	30	143	120	60	32	SOLT 10T3...
DIS 030.5x4D S10	30.5	148	124	68	40	SOLT 10T3...
DIS 031x4D S10	31	148	124	68	40	SOLT 10T3...
DIS 031.5x4D S10	31.5	152	128	68	40	SOLT 10T3...
DIS 032x4D S10	32	152	128	68	40	SOLT 10T3...
DIS 032.5x4D S10	32.5	157	132	68	40	SOLT 10T3...
DIS 033x4D S10	33	157	132	68	40	SOLT 10T3...
DIS 033.5x4D S11	33.5	161	136	68	40	SOLT 1104...
DIS 034x4D S11	34	161	136	68	40	SOLT 1104...
DIS 034.5x4D S11	34.5	166	140	68	40	SOLT 1104...
DIS 035x4D S11	35	166	140	68	40	SOLT 1104...
DIS 035.5x4D S11	35.5	170	144	68	40	SOLT 1104...
DIS 036x4D S11	36	170	144	68	40	SOLT 1104...
DIS 036.5x4D S11	36.5	175	148	68	40	SOLT 1104...
DIS 037x4D S11	37	175	148	68	40	SOLT 1104...
DIS 037.5x4D S11	37.5	179	152	68	40	SOLT 1104...
DIS 038x4D S11	38	179	152	68	40	SOLT 1104...
DIS 038.5x4D S13	38.5	184	156	68	40	SOLT 1305...
DIS 039x4D S13	39	184	156	68	40	SOLT 1305...
DIS 039.5x4D S13	39.5	188	160	68	40	SOLT 1305...
DIS 040x4D S13	40	188	160	68	40	SOLT 1305...
DIS 040.5x4D S13	40.5	193	164	68	40	SOLT 1305...
DIS 041x4D S13	41	193	164	68	40	SOLT 1305...
DIS 041.5x4D S13	41.5	197	168	68	40	SOLT 1305...
DIS 042x4D S13	42	197	168	68	40	SOLT 1305...
DIS 042.5x4D S13	42.5	202	172	68	40	SOLT 1305...
DIS 043x4D S13	43	202	172	68	40	SOLT 1305...
DIS 043.5x4D S13	43.5	206	176	68	40	SOLT 1305...
DIS 044x4D S13	44	206	176	68	40	SOLT 1305...

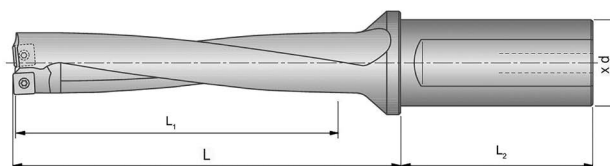
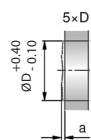

Артикул	D	L	L ₁	L ₂	d	Размеры пластин
DIS 014x5D S05	14	83	70	50	20	SOLT 0502...
DIS 014.5x5D S05	14.5	89	75	50	20	SOLT 0502...
DIS 015x5D S05	15	89	75	50	20	SOLT 0502...
DIS 015.5x5D S05	15.5	96	80	50	20	SOLT 0502...
DIS 016x5D S05	16	96	80	50	20	SOLT 0502...
DIS 016.5x5D S05	16.5	102	85	50	20	SOLT 0502...
DIS 017x5D S06	17	102	85	50	20	SOLT 06T2...
DIS 017.5x5D S06	17.5	107	90	56	25	SOLT 06T2...
DIS 018x5D S06	18	107	90	56	25	SOLT 06T2...
DIS 018.5x5D S06	18.5	113	95	56	25	SOLT 06T2...
DIS 019x5D S06	19	113	95	56	25	SOLT 06T2...
DIS 019.5x5D S06	19.5	118	100	56	25	SOLT 06T2...
DIS 020x5D S07	20	118	100	56	25	SOLT 0703...
DIS 020.5x5D S07	20.5	124	105	56	25	SOLT 0703...
DIS 021x5D S07	21	124	105	56	25	SOLT 0703...
DIS 021.5x5D S07	21.5	129	110	56	25	SOLT 0703...
DIS 022x5D S07	22	129	110	56	25	SOLT 0703...
DIS 022.5x5D S07	22.5	135	115	56	25	SOLT 0703...
DIS 023x5D S07	23	135	115	56	25	SOLT 0703...
DIS 023.5x5D S08	23.5	140	120	60	32	SOLT 0803...
DIS 024x5D S08	24	140	125	60	32	SOLT 0803...
DIS 024.5x5D S08	24.5	146	125	60	32	SOLT 0803...
DIS 025x5D S08	25	146	130	60	32	SOLT 0803...
DIS 025.5x5D S08	25.5	151	130	60	32	SOLT 0803...
DIS 026x5D S08	26	151	135	60	32	SOLT 0803...
DIS 026.5x5D S08	26.5	157	135	60	32	SOLT 0803...
DIS 027x5D S08	27	157	135	60	32	SOLT 0803...
DIS 027.5x5D S08	27.5	162	140	60	32	SOLT 0803...
DIS 028x5D S08	28	162	140	60	32	SOLT 0803...
DIS 028.5x5D S10	28.5	168	145	60	32	SOLT 10T3...
DIS 029x5D S10	29	168	145	60	32	SOLT 10T3...
DIS 029.5x5D S10	29.5	173	150	60	32	SOLT 10T3...
DIS 030x5D S10	30	173	150	60	32	SOLT 10T3...
DIS 030.5x5D S10	30.5	179	155	68	40	SOLT 10T3...
DIS 031x5D S10	31	179	155	68	40	SOLT 10T3...
DIS 031.5x5D S10	31.5	184	160	68	40	SOLT 10T3...
DIS 032x5D S10	32	184	160	68	40	SOLT 10T3...
DIS 032.5x5D S10	32.5	190	165	68	40	SOLT 10T3...
DIS 033x5D S10	33	190	165	68	40	SOLT 10T3...
DIS 033.5x5D S11	33.5	195	170	68	40	SOLT 1104...
DIS 034x5D S11	34	195	170	68	40	SOLT 1104...
DIS 034.5x5D S11	34.5	201	175	68	40	SOLT 1104...
DIS 035x5D S11	35	206	175	68	40	SOLT 1104...
DIS 035.5x5D S11	35.5	206	180	68	40	SOLT 1104...
DIS 036x5D S11	36	212	180	68	40	SOLT 1104...
DIS 036.5x5D S11	36.5	212	185	68	40	SOLT 1104...
DIS 037x5D S11	37	212	185	68	40	SOLT 1104...
DIS 037.5x5D S11	37.5	217	190	68	40	SOLT 1104...
DIS 038x5D S11	38	217	190	68	40	SOLT 1104...
DIS 038.5x5D S13	38.5	223	195	68	40	SOLT 1305...
DIS 039x5D S13	39	223	195	68	40	SOLT 1305...
DIS 039.5x5D S13	39.5	228	200	68	40	SOLT 1305...
DIS 040x5D S13	40	228	200	68	40	SOLT 1305...
DIS 040.5x5D S13	40.5	234	205	68	40	SOLT 1305...
DIS 041x5D S13	41	234	205	68	40	SOLT 1305...
DIS 041.5x5D S13	41.5	239	210	68	40	SOLT 1305...
DIS 042x5D S13	42	239	210	68	40	SOLT 1305...
DIS 042.5x5D S13	42.5	245	215	68	40	SOLT 1305...
DIS 043x5D S13	43	245	215	68	40	SOLT 1305...
DIS 043.5x5D S13	43.5	250	220	68	40	SOLT 1305...
DIS 044x5D S13	44	250	220	68	40	SOLT 1305...

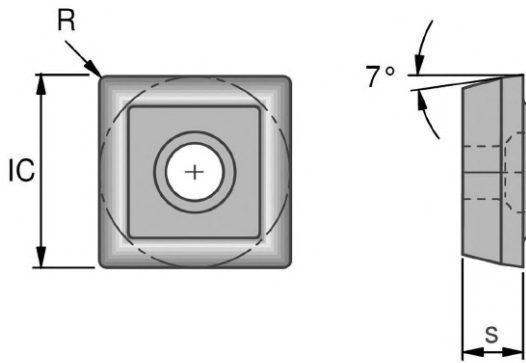

Артикул	IC	s	R			
SOLT 050204 MR	5.0	2.1	0.4	●		
SOLT 050204 M-AF	5.0	2.1	0.4		●	
SOLT 050204 SCE	5.0	2.1	0.4			●
SOLT 050204 MS	5.0	2.1	0.4		●	
SOLT 06T206 MR	5.8	2.5	0.6	●		
SOLT 06T206 M-AF	5.8	2.5	0.6		●	
SOLT 06T206 SCE	5.8	2.5	0.6			●
SOLT 06T206 MS	5.8	2.5	0.6		●	
SOLT 070308 MR	6.9	3.0	0.8	●		
SOLT 070308 M-AF	6.9	3.0	0.8		●	
SOLT 070308 SCE	6.9	3.0	0.8			●
SOLT 070308 MS	6.9	3.0	0.8		●	
SOLT 080308 MR	8.4	3.5	0.8	●		
SOLT 080308 M-AF	8.4	3.5	0.8		●	
SOLT 080308 SCE	8.4	3.5	0.8			●
SOLT 080308 MS	8.4	3.5	0.8		●	
SOLT 10T308 MR	10.3	4.0	0.8	●		
SOLT 10T308 M-AF	10.3	4.0	0.8		●	
SOLT 10T308 SCE	10.3	4.0	0.8			●
SOLT 10T308 MS	10.3	4.0	0.8		●	
SOLT 110408 MR	11.1	4.4	0.8	●		
SOLT 110408 M-AF	11.1	4.4	0.8		●	
SOLT 110408 SCE	11.1	4.4	0.8			●
SOLT 110408 MS	11.1	4.4	0.8		●	
SOLT 130508 MR	13.3	5.0	0.8	●		
SOLT 130508 M-AF	13.3	5.0	0.8		●	
SOLT 130508 SCE	13.3	5.0	0.8			●
SOLT 130508 MS	13.3	5.0	0.8		●	
					P125D	M40D
P Steel - Сталь				●		
M Stainless steel aust. - Аустенитная нерж. сталь					●	
K Cast iron - Чугун						●
S Hig. temp. alloy - Жаропрочные сплавы					●	

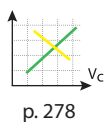

Alloy description

Описание сплавов

P125D

HC-P25 I HC-M25

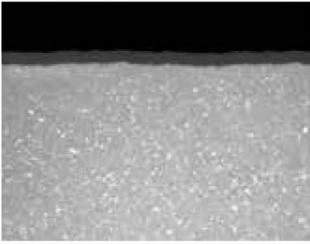

Specification:

Composition: Composition: Co 9.0%; mixed carbides 4.0%; WC balance;

Grain size: fine/medium

Hardness: HV30 1510;

Coating specification: PVD TiAlN/TiN;

Recommended application: Particularly suitable for the machining of steels.

Состав: Со 9.0%; Соединения карбидов 4.0%; WC остальное;

Размер зерна: мелкий / средний

Твердость: HV30 1510;

Состав покрытия: PVD TiAlN/TiN;

Рекомендации к применению: Первый выбор для обработки стали.

M40D

HC-M40 I HC-P40

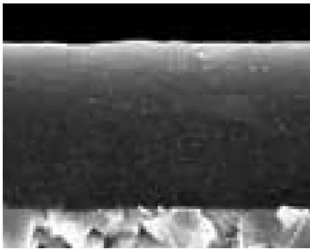

Specification:

Composition: Co 9.0%; mixed carbides 0.7%; WC balance;

Grain size: submicron

Hardness: HV30 1590;

Coating specification: PVD TiAlN;

Recommended application: The first choice for the machining of austenitic steels as well as heat-resistant alloys.

Состав: Со 9.0%; Соединения карбидов 0.7%; WC остальное;

Размер зерна: субмикронный

Твердость: HV30 1590;

Состав покрытия: PVD TiAlN;

Рекомендации к применению: Первый выбор для обработки аустенитной стали и жаропрочных сплавов

K115D

HC-K15

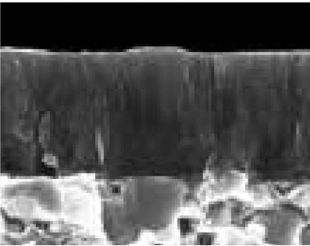

Specification:

Composition: Co 6.0%; WC balance; mixed carbides 2.0%;

Grain size: fine

Hardness: HV30 1630;

Recommended application: Suitable for cast iron machining.



Состав: Со 6.0%; Соединения карбидов 2.0%;

Размер зерна: мелкий

Твердость: HV30 1630;

Состав покрытия: без покрытия;

Рекомендации к применению: Разработан для обработки чугунов

Guideline values for solid drilling					Cutting speed v_c (m/min)								
Material group	Strength R_m (N/mm ²)	Hardness HB	Material	Material example, material code/DIN	 P125D			 M40D			 K115D		
					min	opt.	max	min	opt.	max	min	opt.	max
P	1.0	≤ 500	non-alloy steels	1.0037 (S235JR) 1.0715 (11SMn30) 1.0044 (S2575JR)	200	260	320	200	250	300	250	300	350
	2.0	500-900	non-alloy / low alloy steels	1.0050 (E295) 1.0535 (C55) 1.7131 (16MnCr5)	250	270	300	250	270	300	250	270	300
	2.1	< 500	lead alloys	1.0718 (11SMnPb30)	200	260	320	160	220	280	250	300	350
	3.0	> 900	low alloy steels: heat resistant structural, heat treated, nitride and tools steels	1.7225 (42CrMo4) 1.1221 (C60E)	140	180	220	120	160	200	200	240	280
	4.0	> 900	high alloy steels	1.2341 (6CrMo15-5) 1.2601 (X165CrMoV12)	120	160	200	120	160	200	200	240	280
	4.1		HSS		50	70	90	40	60	80	170	200	230
S	5.0		250	special alloys: Inconel, Hastelloy, Nimonic, stc 2.4668 (NiuCr19Fe19Nb5Mo3) 2.4631 (Nimonic 80A)	on request								
	5.1	400		titanium, titanium alloys 3.7115 (TiAl5Sn2.5)	on request								
M	6.0	≤ 600		stainless steels 1.4306 (X2CrNi19-11) 1.4401 (X5CrNiMo17-12-2)	150	170	210	140	180	220	210	240	270
	6.1	< 900		stainless steels 1.4511 (X3CrNb17) 1.4571 (X10CrNiMoTi17-12-2)	120	150	200	120	160	200	190	220	250
	7.0	> 900		stainless / fireproof steels 1.4713 (X10CrAlSi7) 1.4862 (X8NiCrSi38-18)	110	150	190	120	160	200	190	220	250
K	8.0		180	gray cast iron 0.6025 (EN-GJL-250) 0.6035 (EN-GJL-350)	120	160	200	110	150	190	160	240	320
	8.1		250	alloy gray cast iron 0.6660 (GGL-NiCr20 2)	90	120	150	80	110	140	100	140	180
	9.0	≤ 600	250	spheroidal graphite cast iron, ferritic 0.7040 (EN-GJS-400-15)	120	160	200	110	150	190	120	160	200
	9.1		230	spheroidal graphite cast iron, ferritic/perlitic 0.7050 (EN-GJS-500-7) 0.7055 (GJS-55) 0.8055 (GTW-55)	110	140	170	110	130	160	100	140	180
	10.0	> 600	250	spheroidal graphite cast iron, perlitic malleable iron 0.7060 (EN-GJS-600-3) 0.8165 (GTS-65)	90	120	150	80	110	140	90	120	150
	10.1		200	alloyed spheroidal graphite cast iron 0.7661 (EN-GJSA-XNiCr20-2)	90	120	150	80	110	140	90	120	150
	10.2		300	vermicular cast iron EN-GJV Ti < 0,2 EN-GJV Ti > 0,2	80	100	120	70	90	110	70	100	130

Feed f (mm/rev)						
Ø 14 – 16.5 f (mm/min)	Ø 17 – 19.5 f (mm/min)	Ø 20 – 23 f (mm/min)	Ø 23.5 – 28 f (mm/min)	Ø 28.5 – 33 f (mm/min)	Ø 33.5 – 38 f (mm/min)	Ø 38.5 – 44 f (mm/min)
0.04 – 0.1	0.08 – 0.1	0.06 – 0.12	0.06 – 0.12	0.06 – 0.12	0.06 – 0.12	0.06 – 0.12
0.04 – 0.14	0.1 – 0.15	0.11 – 0.16	0.11 – 0.16	0.11 – 0.13	0.11 – 0.16	0.11 – 0.16
0.06 – 0.16	0.1 – 0.16	0.13 – 0.18	0.13 – 0.2	0.15 – 0.2	0.15 – 0.2	0.15 – 0.2
0.06 – 0.16	0.11 – 0.16	0.13 – 0.22	0.14 – 0.22	0.14 – 0.22	0.14 – 0.22	0.14 – 0.22
0.06 – 0.15	0.1 – 0.15	0.12 – 0.22	0.14 – 0.22	0.14 – 0.22	0.14 – 0.22	0.14 – 0.22
-	-	-	-	-	-	-
on request						
on request						
0.06 – 0.12	0.08 – 0.12	0.1 – 0.18	0.12 – 0.18	0.1 – 0.18	0.1 – 0.18	0.1 – 0.18
0.06 – 0.12	0.08 – 0.12	0.1 – 0.18	0.12 – 0.18	0.12 – 0.18	0.12 – 0.18	0.12 – 0.18
0.06 – 0.1	0.06 – 0.16	0.09 – 0.16	0.1 – 0.16	0.1 – 0.16	0.1 – 0.16	0.1 – 0.16
0.1 – 0.16	0.1 – 0.18	0.14 – 0.25	0.18 – 0.3	0.2 – 0.3	0.2 – 0.3	0.2 – 0.3
0.08 – 0.16	0.1 – 0.16	0.12 – 0.23	0.16 – 0.28	0.18 – 0.28	0.18 – 0.28	0.18 – 0.28
0.08 – 0.18	0.12 – 0.18	0.14 – 0.25	0.18 – 0.3	0.2 – 0.3	0.2 – 0.3	0.2 – 0.3
0.08 – 0.18	0.12 – 0.18	0.14 – 0.25	0.18 – 0.3	0.2 – 0.3	0.2 – 0.3	0.2 – 0.3
0.08 – 0.18	0.12 – 0.18	0.14 – 0.25	0.18 – 0.3	0.2 – 0.3	0.2 – 0.3	0.2 – 0.3
0.08 – 0.16	0.1 – 0.16	0.12 – 0.23	0.16 – 0.28	0.18 – 0.28	0.18 – 0.28	0.18 – 0.28
0.08 – 0.15	0.09 – 0.15	0.11 – 0.22	0.15 – 0.27	0.17 – 0.27	0.17 – 0.27	0.17 – 0.27

XPNT Inserts

XPNT Пластины

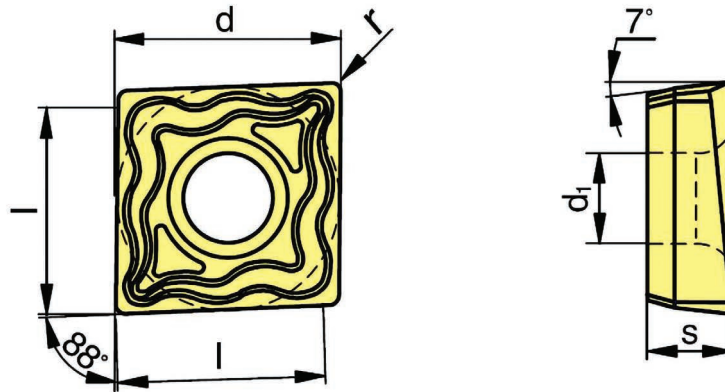

Designation	Ø d (mm)	l (mm)	s (mm)	r (mm)	d ₁ (mm)	P125MT	PMS30MT	PMS35MT
XPNT 040204EL	4.50	4.00	1.80	0.40	2.10	on request по запросу	●	●
XPNT 040204ER	4.50	4.00	1.80	0.40	2.10		●	●
XPNT 050204EN	5.80	5.00	2.10	0.40	2.25		●	●
XPNT 060204EN	6.50	6.00	2.92	0.40	2.50		●	●
XPNT 070304EN	7.60	7.00	3.87	0.40	2.80		●	●
XPNT 080304EN	8.50	8.00	3.87	0.40	3.40		●	●
XPNT 090404EN	9.60	9.00	4.66	0.40	3.40		●	●
XPNT 100404EN	10.60	10.00	4.66	0.40	4.40		●	●
XPNT 100408EN	10.60	10.00	4.66	0.80	4.40		●	●
XPNT 130504EN	13.50	12.50	5.45	0.40	5.30		●	●
XPNT 130508EN	13.50	12.50	5.45	0.80	5.30		●	●
XPNT 170608EN	17.50	16.00	6.25	0.80	5.30		●	●
						P125MT	PMS30MT	PMS35MT
P Steel - Сталь						●	●	●
M Stainless steel aust. - Аустенитная нерж. сталь						○	●	○
K Cast iron - Чугун						●	○	●
N Aluminium - Алюминиевые сплавы							○	
S Hig. temp. alloy - Жаропрочные сплавы							●	
H Hardened steel - Закаленные стали								

- Main application
- Extended application

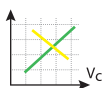

р. 286



р. 287

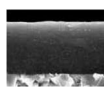

р. 285



р. 282-283

XPET Inserts for aluminium

XPET Пластины для алюминия

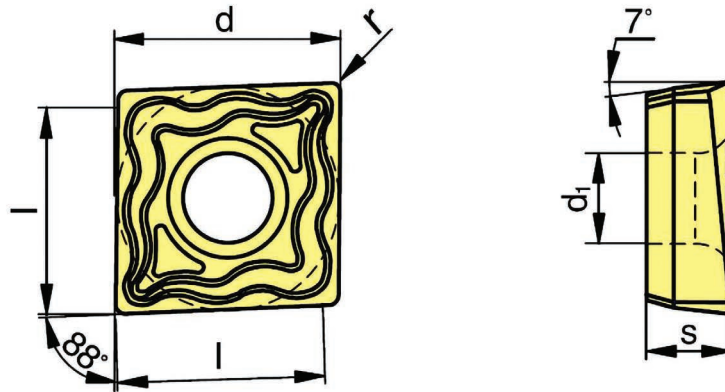

Designation	$\varnothing d$ (mm)	l (mm)	s (mm)	r (mm)	d ₁ (mm)	N15MT
XPET 050204FN	5.80	5.00	2.10	0.40	2.25	●
XPET 060204FN	6.50	6.00	2.92	0.40	2.50	●
XPET 070304FN	7.60	7.00	3.87	0.40	2.80	●
XPET 080304FN	8.50	8.00	3.87	0.40	3.40	●
XPET 09T304FN	9.60	9.00	4.66	0.40	3.40	●
XPET 10T304FN	10.60	10.00	4.66	0.40	4.40	●
XPET 130504FN	13.50	12.50	5.45	0.40	5.30	●
XPET 170608FN	17.50	16.00	6.25	0.80	5.30	●

	N15MT
P Steel - Сталь	
M Stainless steel aust. - Аустенитная нерж. сталь	
K Cast iron - Чугун	
N Aluminium - Алюминиевые сплавы	●
S Hig. temp. alloy - Жаропрочные сплавы	
H Hardened steel - Закаленные стали	

- Main application
- Extended application

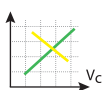

р. 286



р. 287

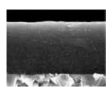

р. 285





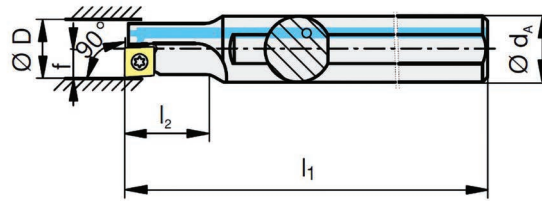

р. 282-283

Drilling depth up to 1.5 x D Available range for XPNT and XPET



Drawing shows right-hand tool

Ø D (mm)	Type Description	dA [mm]	l ₁ [mm]	l ₂ [mm]	f [mm]	 [XPNT/XPET]			
8.00	VTR/L D08x12.0x04*	12.00	80.00	12.00	4.00	XPNT 0402	11807484	-	11843205
10.00	VTR/L D10x15.0x05	12.00	90.00	15.00	5.00	XP...T 0502	11807480	-	11843205
12.00	VTR/L D12x18.0x06	16.00	100.00	18.00	6.00	XP...T 0602	11684214	-	11488748
14.00	VTR/L D14x21.0x07	16.00	110.00	21.00	7.00	XP...T 0703	11684216	-	11206195
16.00	VTR/L D16x24.0x08	20.00	125.00	24.00	8.00	XP...T 0803	11227305	-	11843208
18.00	VTR/L D18x27.0x09	25.00	135.00	27.00	9.00	XP...T 0904	11227305	-	11843208
20.00	VTR/L D20x30.0x10	25.00	150.00	30.00	10.00	XP...T 1004	11610311	11450858	-
25.00	VTR/L D25x37.5x13	32.00	180.00	37.50	12.50	XP...T 1305	11801441	11816974	-
32.00	VTR/L D32x48.0x17	40.00	200.00	48.00	16.00	XP...T 1706	11801441	11816974	-

* Right-hand holder / Right-hand indexable insert

* Left-hand holder / Left-hand indexable insert

Drilling depth up to 2.25 x D

Available range for XPNT and XPET

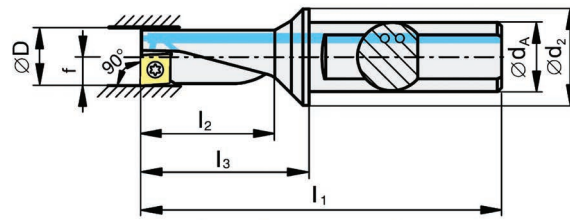

Drawing shows right-hand tool

$\varnothing D$ (mm)	Type Description	d_A [mm]	d_2 [mm]	l_1 [mm]	l_2 [mm]	l_3 [mm]	f [mm]	[XPNT/XPET]			
8.00	VTR/L D08x18.0x04	10.00	15.00	60.00	18.00	22.00	4.00	XPNT 0402	11807484	-	11843205
10.00	VTR/L D10x22.5x05	12.00	18.00	69.50	22.50	27.50	5.00	XP...T 0502	11807480	-	11843205
12.00	VTR/L D12x27.0x06	16.00	22.00	78.00	27.00	33.00	6.00	XP...T 0602	11684214	-	11488748
14.00	VTR/L D14x31.5x06	16.00	23.00	83.50	31.50	38.50	7.00	XP...T 0703	11684216	-	11206195
16.00	VTR/L D16x36.0x08	20.00	28.00	94.00	36.00	44.00	8.00	XP...T 0803	11227305	-	11843208
18.00	VTR/L D18x40.5x09	25.00	36.00	109.50	40.50	53.50	9.00	XP...T 0904	11227305	-	11843208
20.00	VTR/L D20x45.0x10	25.00	35.00	111.00	45.00	55.00	10.00	XP...T 1004	11610311	11450858	-
25.00	VTR/L D25x56.5x13	32.00	44.00	129.00	56.50	69.00	12.50	XP...T 1304	11801441	11816974	-
32.00	VTR/L D32x72.0x17	40.00	54.00	158.00	72.00	88.00	16.00	XP...T 1706	11801441	11816974	-

* Right-hand holder / Right-hand indexable insert

* Left-hand holder / Left-hand indexable insert

Grade overview

Grade description	Standard designation			Application/ Область применения													P	M	K	N	S	H
	ISO	ANSI	*Type of cutting material	01	05	10	15	20	25	30	35	40	45	50	Steel Сталь	Stainless steel Нержавеющая сталь	Cast iron Чугун	Aluminium Легкие сплавы	Superalloy Жаропрочные сплавы	Hard materials Закаленные стали		
				Application/ Область применения													Steel Сталь	Stainless steel Нержавеющая сталь	Cast iron Чугун	Aluminium Легкие сплавы	Superalloy Жаропрочные сплавы	Hard materials Закаленные стали
P125MT	HC-P25	C6	C												●							
	HC-K30	C1	C														●					
	HC-M20	-	C													○						
PMS30MT	HC-P30	C6	P												●							
	HC-M25	-	P													●						
	HC-S25	-	P													○				●		
	HC-K30	C1	P														○					
	HC-N25	C2	P																○			
PMSS35MT	HC-P35	C5	P												●							
	HC-M30	-	P													●						
	HC-S30	-	P																	●		
N15MT	HW-K15	C2	K															●				

- Main application
- Extended application

Alloy description

Описание сплавов

P125MT

HC-P25 | HC-K30 | HC-M20

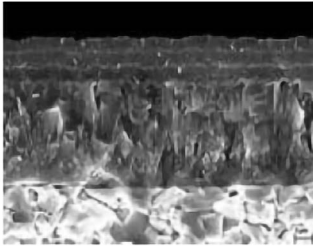

Composition: Co 7.0%; mixed carbides 8.1%; WC balance

Grain size: 1-2 μm

Hardness: HV30 1450

Coating specification: CVD Ti(CN) + Al₂O₃ multi-layer

Recommended application: The wear-resistant solution for steel and cast iron under stable conditions and with high cutting speed

Состав: Со 7.0%; Соединения карбидов 8.1%; WC остальное

Размер зерна: 1-2 μm

Твердость: HV30 1450

Состав покрытия: CVD Ti(CN) + Al₂O₃ многослойный

Рекомендации к применению: Первый выбор для обработки чугуна.

PMS30MT

HC-P30 | HC-M25 | HC-S25 | HC-K30 |

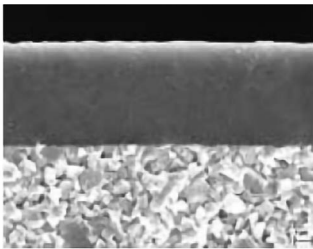

Composition: Co 9.0%; others 0.75%; WC balance

Grain size: 0.85 μm

Hardness: HV30 1590

Coating specification: PVD TiAlN

Recommended application: The universal high-performance grade for steel, austenitic steel and heat-resistant alloys

Состав: Со 9.0%; Соединения карбидов 0.75%; WC остальное

Размер зерна: 0.85 μm

Твердость: HV30 1590

Состав покрытия: PVD TiAlN

Рекомендации к применению: Универсальный высокоэффективный сплав для обработки стали, аустенитной стали и жаропрочных сплавов

PMS35MT

HC-P35 | HC-M30 | HC-S30

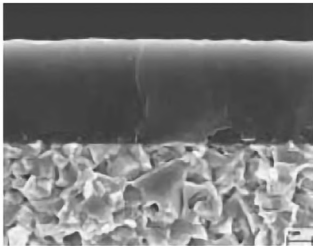

Composition: Co 10.3%; others 1.2%; WC balance

Grain size: 0.7 μm

Hardness: HV30 1600

Coating specification: PVD TiN / TiAlN

Recommended application: The universal high-performance grade for steel, austenitic steel and heat-resistant alloys

Состав: Со 10.3%; Соединения карбидов 1.2%; WC остальное

Размер зерна: 0.7 μm

Твердость: HV30 1600

Состав покрытия: PVD TiAlN

Рекомендации к применению: Универсальный высокоэффективный сплав для обработки стали, аустенитной стали и жаропрочных сплавов.

N15MT

HW-K15

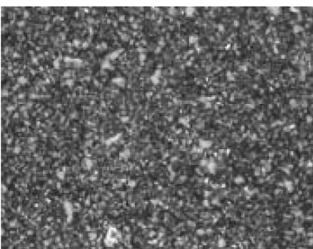

Composition: Co 6.0% | WC balance; other: 0.20%

Grain size: 0.8-1.3 μm

Hardness: HV30 1650

Coating specification: without

Recommended application: The uncoated carbide grade for the machining of aluminium and other non-ferrous metals.

Состав: Со 6.0%; Соединения карбидов 0.20%; WC остальное

Размер зерна: 0.8-1.3 μm

Твердость: HV30 1650

Состав покрытия: нет

Рекомендации к применению: непокрытый сплав для обработки алюминия и других материалов не содержащих железо.

Grades / materials

Cutting data

Work piece material		Type of treatment / alloy	Coated carbide			
			P125MT Vc [m/min]	PMS30MT Vc [m/min]	PMS35MT Vc [m/min]	N15MT Vc [m/min]
P	Steel	Non-alloyed steel	270 – 90	230 – 50	250 – 70	-
		Low-alloyed steel	270 – 70	160 – 50	180 – 60	-
		High-alloyed steel	170 – 60	150 – 50	160 – 50	-
		Corrosion-resistant steel	200 – 90	180 – 50	180 – 70	-
M	Stainless steel	Stainless steel	200 – 90	160 – 50	180 – 90	-
			-	-	-	-
			-	-	-	-
			-	-	-	-
K	Cast iron	Grey cast iron	250 – 120	180 – 90	230 – 90	-
		Spheroidal cast iron	250 – 110	180 – 90	230 – 110	-
		Malleable cast iron	250 – 100	140 – 60	230 – 90	-
			-	-	-	-
N	Non-ferrous metals	Aluminium wrought alloys	-	1800 – 70	1800 – 70	100 – 2250
		Aluminium cast alloys	-	1350 – 70	1350 – 70	100 – 1250
		Copper and copper alloys (bronze, brass)	-	360 – 70	360 – 70	100 – 600
		Non-metallic materials	-	180 – 50	180 – 50	60 – 220
S	Heat resistant alloys	Heat-resistant alloys	-	80 – 20	50 – 10	-
		Titanium alloys	-	90 – 30	110 – 30	-
			-	-	-	-
			-	-	-	-

Depth of cut / feed rate – 1.5 x D
Глубина обработки / подача -1,5 x D



Turning of Internal profiles

Токарная обработка внутренниъ профилей

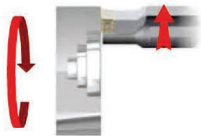
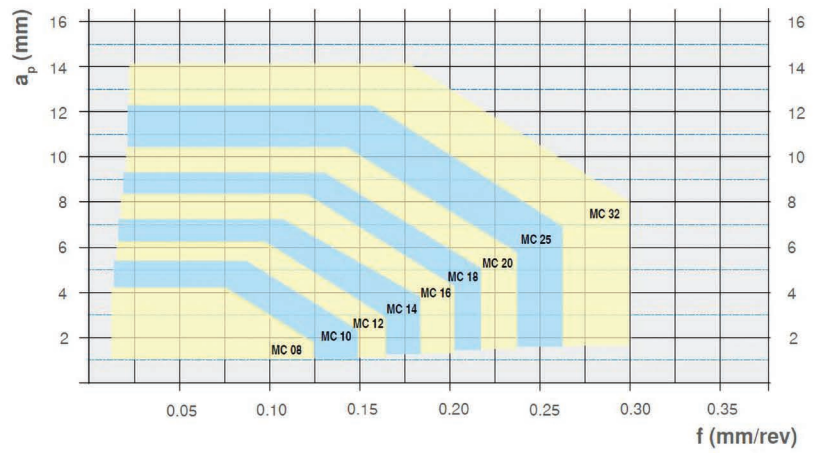

Facing operations
 Подрезка торца

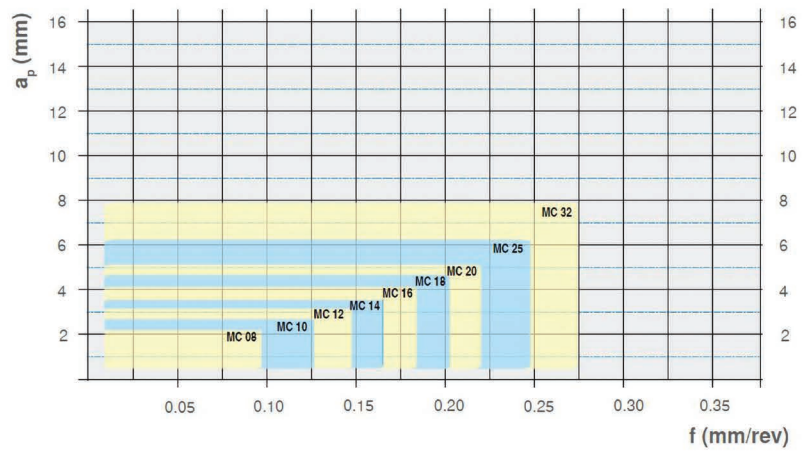

Depth of cut / feed rate – 2.25 x D
Глубина обработки / подача - 2.25 x D

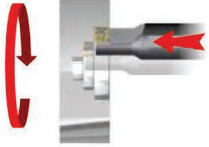

Turning of Internal profiles
 Токарная обработка внутренних профилей

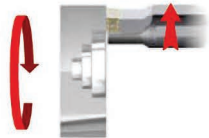
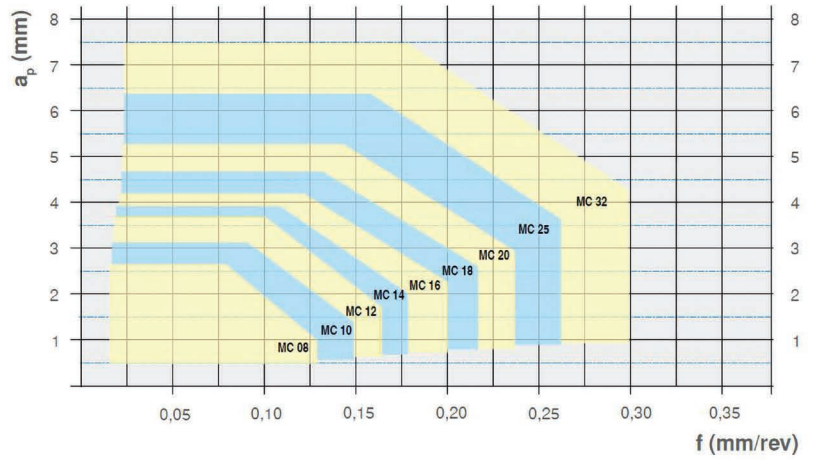

Facing operations
 Подрезка торца

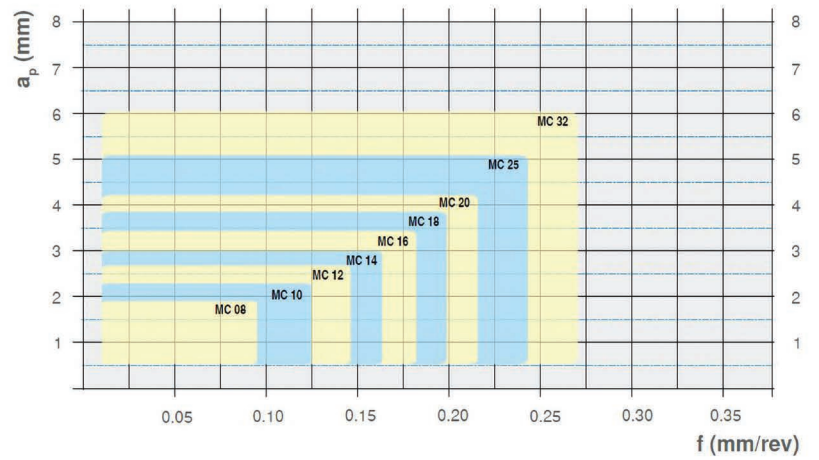

Drilling depth / feed rate Глубина обработки / подача - 2.25 x D

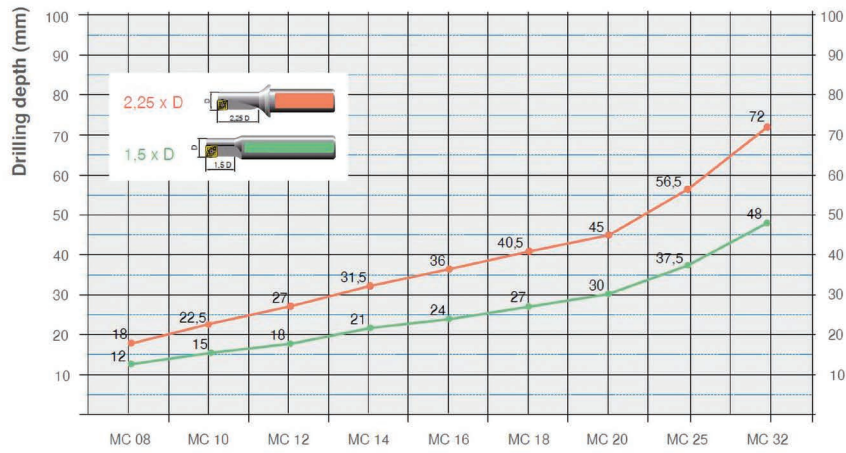

Drilling depth
Глубина сверления

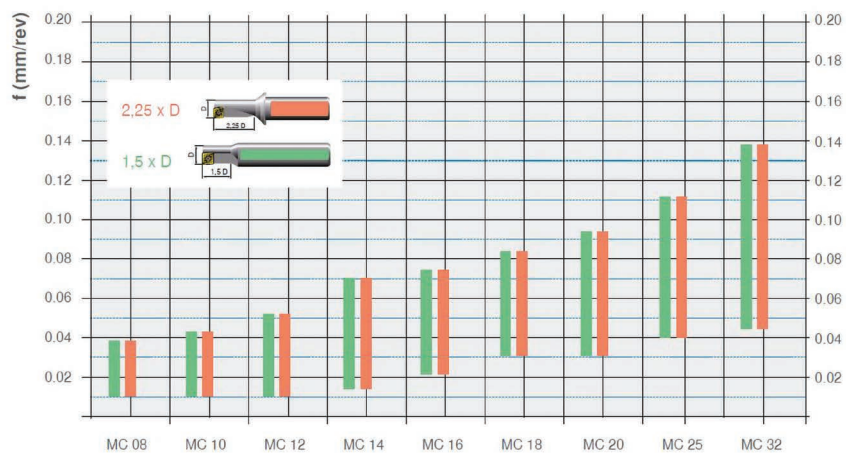

Drilling feed rate
Подача при сверления

Application reference

Руководство по применению

Axial displacement of the machine

Осовое смещение

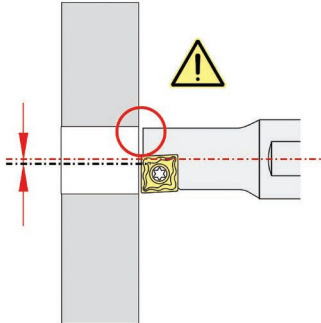

Displacement in x - direction
Смещения в направлении x

Correct tool positioning
Правильное позиционирование
инструмента

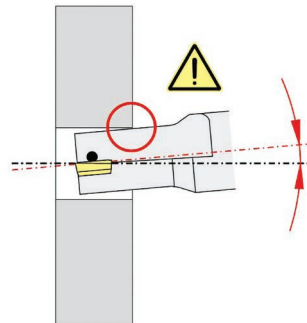

Angular error
Угловая ошибка

Turret and/or spindle adjustment
Необходима регулировка
револьверной головки и/или
шпинделя

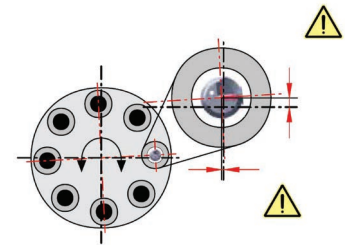

Turret position error
Ошибка положения
револьверной головки

Adjust turret plate (Y-axis)
Отрегулируйте диск
револьверной головки (Y-ось)



Mounting of the insert

For tools \varnothing 8 mm right-hand or left-hand inserts are required. From \varnothing 10-32 mm neutral inserts are applied.

Замена режущей пластины

Для инструментов \varnothing 8 мм требуются правосторонние или левосторонние пластины. От \varnothing 10-32 мм применяют нейтральные пластины.



Through hole

With through holes a sharp-edged disk is created as tool break-out occurs. Safety measures are necessary.

Сквозное отверстие

При сверлении сквозных отверстий, из заготовки выдавливается диск с острыми краями, так как происходит провыв инструмента. Необходимы меры предосторожности.

Off-centre drilling

Смещение оси сверления

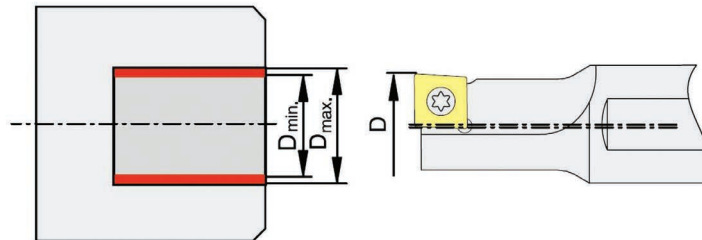

Thanks to the special design of the holder and the indexable inserts off-centre drilling is possible.

Благодаря специальной конструкции державки и режущей пластины, возможно смещение инструмента относительно центра оси вращения заготовки.

Type of tool Solid carbide	Nominal tool D [mm]	Workpiece bore diameter D _{min} [mm]	Workpiece bore diameter D _{max} [mm]
VTR/L 08 ... 04	8.00	7.85	8.30
VTR/L 10 ... 05	10.00	9.85	10.50
VTR/L 12 ... 06	12.00	11.85	12.50
VTR/L 14 ... 07	14.00	13.85	14.50
VTR/L 16 ... 08	16.00	15.85	16.50
VTR/L 18 ... 09	18.00	17.85	18.50
VTR/L 20 ... 10	20.00	19.80	20.50
VTR/L 25 ... 13	25.00	24.80	25.80
VTR/L 32 ... 17	32.00	31.80	33.00

